

ORIGINAL MINI ACCESSORIES. INSTALLATION INSTRUCTIONS.



Portable Navigation Retrofit

MINI COUNTRYMAN (R60)

MINI PACEMAN (R61)

Retrofit cannot be installed in cars with SA 606 (MINI navigation system).

Retrofit kit number

65 90 2 218 328	3.5" LHD portable navigation installation kit
65 90 2 223 483	3.5" RHD portable navigation installation kit
65 90 2 351 408	4.3" LHD portable navigation installation kit
65 90 2 351 409	4.3" RHD portable navigation installation kit

Installation time

When retrofitting the 3.5" navigation device, the installation time is **approx. 0.5 hours**. This may vary depending on the condition of the car and the equipment in it. Where the optional TMC aerial is installed, the installation time increases by **0.25 hours**.

When retrofitting the 4.3" navigation device, the installation time is **approx. 0.75 hours**.

Important information

These installation instructions are primarily intended for use within the BMW dealership organisation and by authorised MINI service companies.

In any event, the target group for these installation instructions is specialist personnel trained on MINI cars with the appropriate specialist knowledge.

All work must be completed using the latest MINI repair manuals, wiring diagrams, servicing manuals and work instructions, in a rational order, using the prescribed tools (special tools) and observing current health and safety regulations.

If you experience installation or function problems, restrict troubleshooting to approx. 0.5 hours for mechanical work and 1.0 hour for electrical work.

To avoid unnecessary extra work and/or costs, send an inquiry straight away to the technical parts support team via the Aftersales Assistance Portal (ASAP).

Quote the following information:

- Chassis number,
- Retrofit kit part number,
- A detailed description of the problem,
- Any work already carried out.

Do not archive the hard copy of these installation instructions since daily updates are provided via ASAP!

Pictograms



Denotes instructions that draw your attention to dangers.



Denotes instructions that draw your attention to special features.

◀ Denotes the end of the instruction or other text.

Information for the customer

Print out the "Customer information" section at the end of the installation instructions and give it to the customer.

Installation information

Ensure that the cables and/or lines are not kinked or damaged as you install them in the vehicle. Costs arising from this will not be reimbursed by BMW AG.

Additional cables/lines that you install must be secured with cable ties.

If the specified PIN chambers are occupied, bridges, double crimps or twin-lead terminals must be used.

All pictures show LHD cars; proceed accordingly on RHD cars.

It is possible to convert a 3.5" navigation device already installed to a 4.3" navigation device. In this case, the existing TMC aerial can continue to be used.

Ordering instructions

When retrofitting the 3.5" navigation device, the TMC aerial **F** is not part of the retrofit kit and can be ordered as an optional extra (for the part number and instructions, see EPC).

When retrofitting the 4.3" navigation device, the mount **G** is not part of the retrofit kit and must be ordered separately (for the part number and instructions, see EPC).

List of special equipment

The following special equipment must be taken into consideration when installing:

SA 606 MINI navigation system

Special tools required

None

1. Table of contents

Section	Page
1. Table of contents	3
2. Parts list	4
3. Preparatory work	5
4. Connection diagram	6
5. Installation and cabling diagram	7
6. Installation	8
7. Concluding work and coding	10
8. Circuit diagram	11
9. Customer information	12

2. Parts list

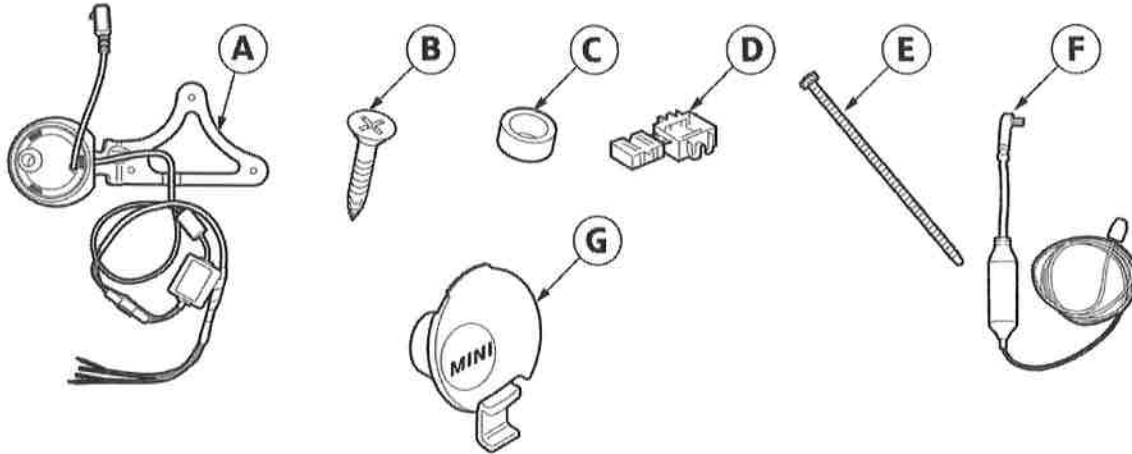

R60 0085 Z

Legend

- A** Navigation device mount with wiring harness
- B** Screw (3 x)
- C** Spacer bush (3 x)
- D** Miniature connector (2 x)
- E** Cable tie (5 x)
- F** TMC aerial (optional, only for 3.5" navigation device or if converting to 4.3" navigation device, not included in the retrofit kit)
- G** Mount (only for 4.3" navigation device or if converting from 3.5" to 4.3" navigation device, not included in the retrofit kit)

3. Preparatory work

	ISTA No.
Conduct a brief test	---
Disconnect the negative pole of the battery	61 20 900 ...
The following components must be removed first of all	
Bottom left dashboard trim	51 45 180
Steering column engine speed display	62 10 100
Only where the optional TMC is installed or the navigation device is converted from 3.5" to 4.3"	
Front roof pillar (A-pillar) trim on the left	51 43 201

4. Connection diagram

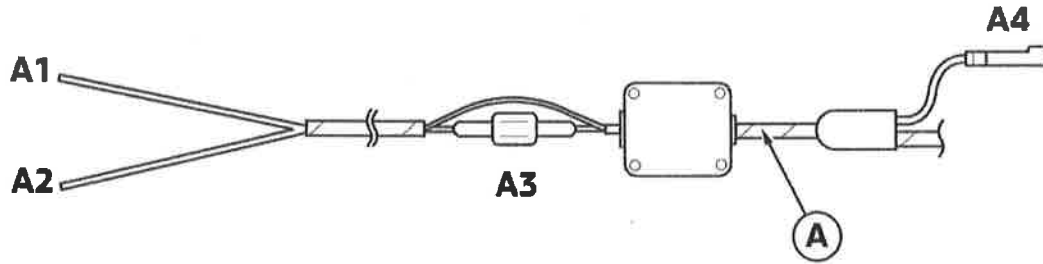

R60 0086 Z

Item	Designation	Signal	Cable colour/ Cross-section	Connection location in the car	Abbreviation/ Slot
A	Wiring harness on navigation device mount A	---	---	---	---
A1	Open cable	Terminal 15	RT 0,50 mm ²	With miniature connector D on the GN/BL cable of the OBD diagnostic socket	X19527 PIN 1
A2	Open cable	Terminal 31	SW 0,50 mm ²	With miniature connector D on the BR cable of the OBD diagnostic socket	X19527 PIN 5
A3	Fuse	---	---	---	---
A4	Mini USB	TMC	---	Only with 3.5" navigation device To TMC aerial F (optional)	---

5. Installation and cabling diagram

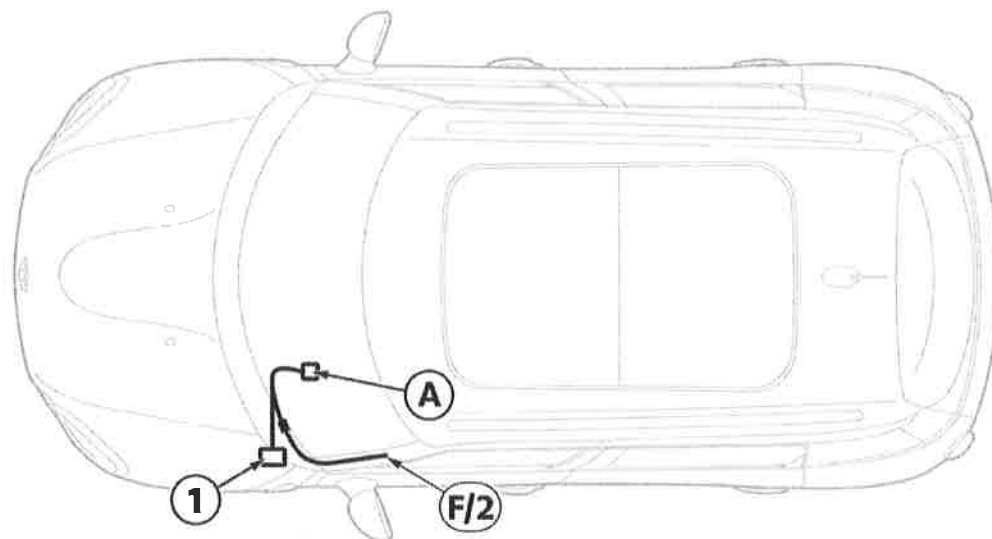

R60 0087 Z

A Navigation device mount
F TMC aerial

1 OBD diagnostic socket **X19527**
2 TMC aerial (into the wiring harness for the 4.3" navigation device)

6. Installation

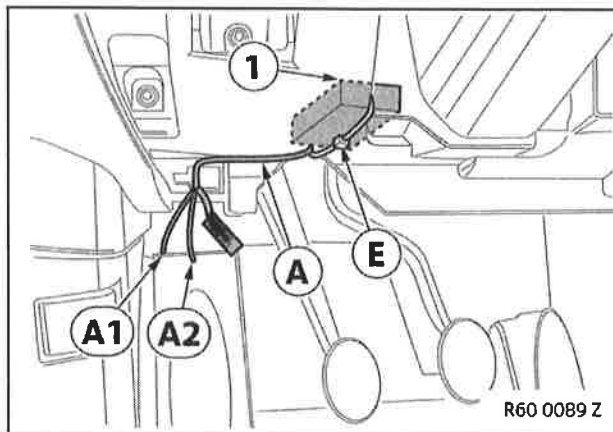

Route the wiring harness of navigation device mount **A** along the steering column of the existing standard wiring harness behind the dashboard.

Secure charging electronics box (1) of the wiring harness to navigation device mount **A** using cable tie **E** on the dashboard.

Route branches **A1** and **A2** to the OBD diagnostic socket.

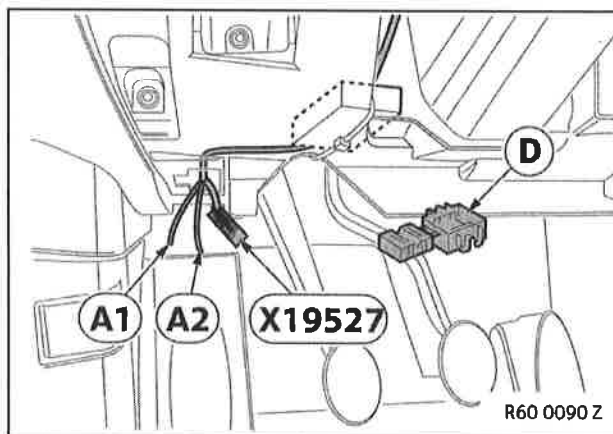

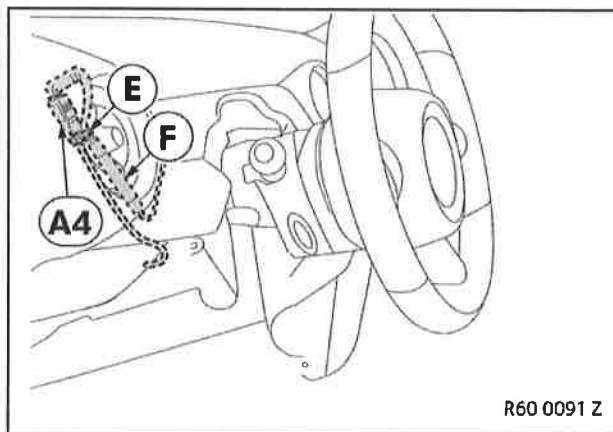

Connect branches **A1** and **A2** as follows to OBD diagnostic socket **X19527**:

- Branch **A1**, RT cable, with miniature connector **D** to the GN/BL cable from PIN 1 of OBD diagnostic socket **X19527**
- Branch **A2**, SW cable, with miniature connector **D** to the BR cable from PIN 5 of OBD diagnostic socket **X19527**

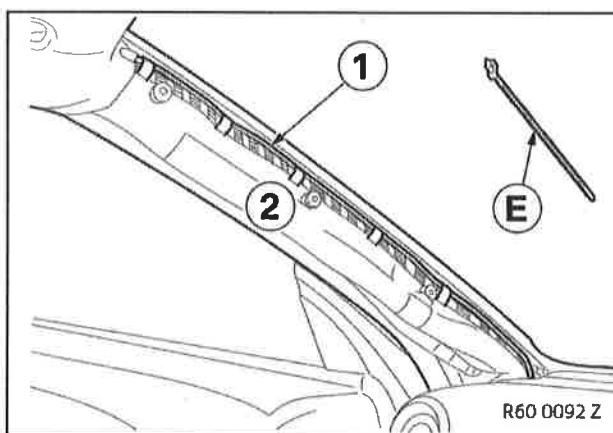

Only with the optional installation of the TMC aerial for 3.5" navigation device or where the navigation device is converted from 3.5" to 4.3" Connect TMC aerial **F** to branch **A4** and secure with cable tie **E**. Route the aerial cable from TMC aerial **F** to the A-pillar.



 The airbag function must not be adversely affected by the cable routing. ◀

Route the aerial cable (1) along the A-pillar (2).

Secure the aerial cable (1) to the standard wiring harness using cable ties **E**.

6. Installation

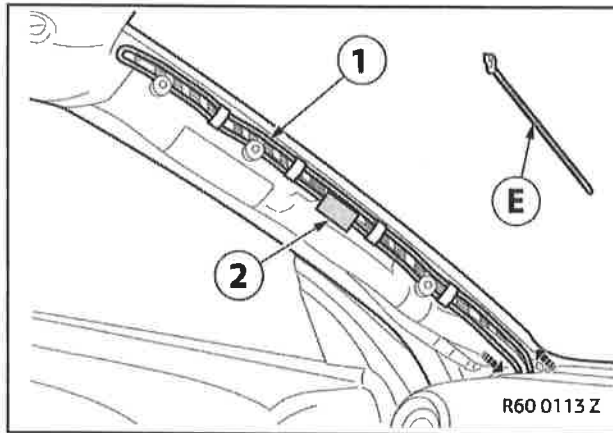

Only with retrofitting of the 4.3" navigation device

▣ The airbag function must not be adversely affected by the cable routing. ◀

Route the aerial cable (1) so that the integrated switch (2) is positioned in the middle of the A-pillar. In this case, the aerial cable (1) must be tied along the entire length of the A-pillar.

Secure the aerial cable (1) to the standard wiring harness using cable ties E.

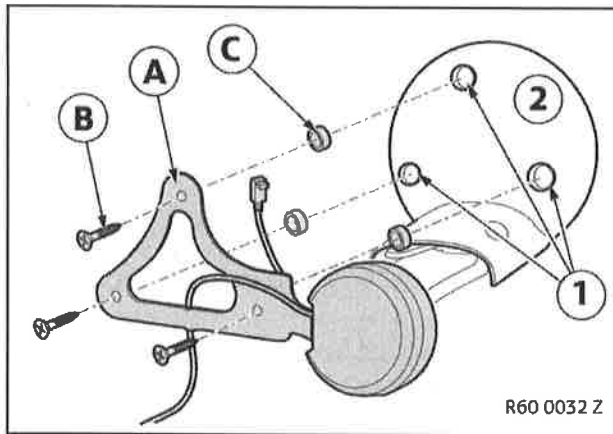

All cars

Undo screws (1) on the steering column instrument (2) (no longer required).

Secure navigation device mount A using screws B and spacer bushes C to the steering column instrument (2).

7. Concluding work and coding

The retrofit system does not require coding.

- Connect the battery
- Conduct a function test
- Re-assemble the car in a logical manner

 The "Customer information" section at the end of the installation instructions must be given to the customer. ◀

8. Circuit diagram

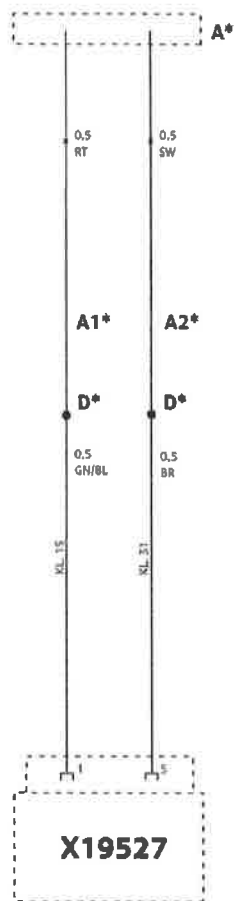

R57 0030 Z

Legend

- A1** Open cable
- A2** Open cable
- D*** Miniature connector
- X19527** OBD diagnostic socket

All the designations marked with an asterisk (*) apply only to these installation instructions or this wiring diagram.

Cable colours

BL	Blue	RT	Red
BR	Brown	SW	Black
GE	Yellow	WS	White
GN	Green	VI	Violet
NT	Natural		

9. Customer information

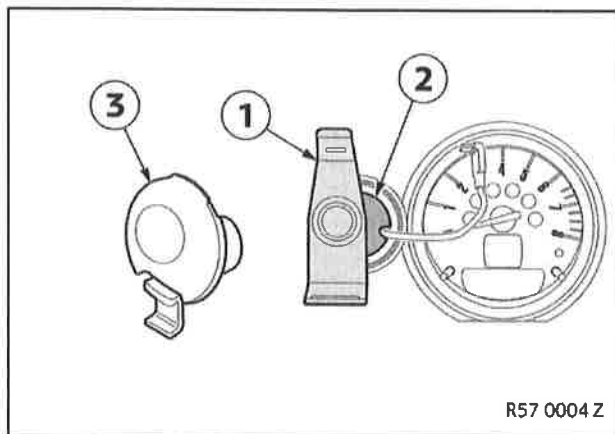

Only with 3.5" navigation device

Place the GPS bracket (1) on the adapter (2).

Only with 4.3" navigation device or conversion from 3.5" to 4.3" navigation unit

Place the mount (3) on the adapter (2).

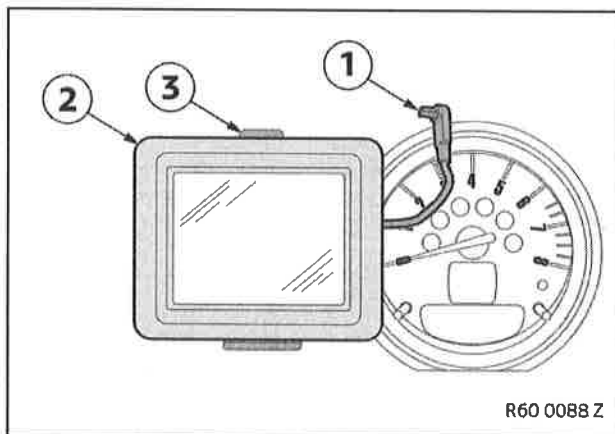

Connect the cable (1) to the navigation device (2).

Slot the navigation device (2) into the GPS bracket (3) or in the mount for the 4.3" navigation device.

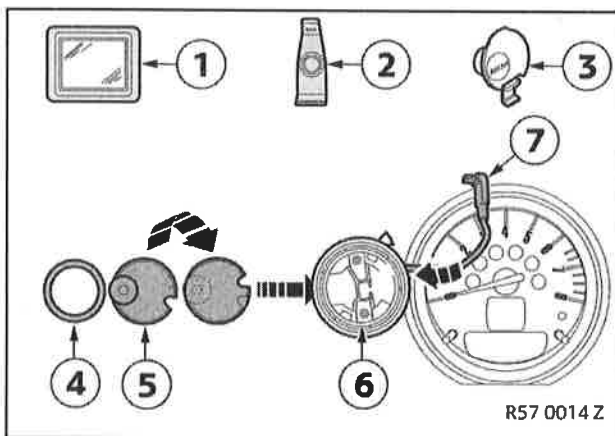

☐ In order to protect your navigation device (1) from theft, you should remove it from the GPS bracket (2) or mount (3) when you leave the vehicle and stow it somewhere secure. In the interests of safety, and in order to avoid potential interest in any navigation device (1) that may be inside the car, the GPS bracket (2) or mount (3) should also be taken with you. ◀

For the 3.5" navigation device: Remove the GPS bracket (2) from the adapter (5).

For the 4.3" navigation device: Remove the mount (3) from the adapter (5).

Remove the securing ring (4) by turning it to the left until it loosens.

Remove the adapter (5).

Push the cable (7) all the way back into the navigation device mount (6).

Slide the adapter (5) with its securing ball inwards into the navigation device mount (6).

Insert the securing ring (4) and tighten it by turning it to the right.