

In order to reduce the interior noise and to prevent condensation water, the cavities are partitioned in specific areas of the body. To do this, shaped parts are inserted in the cavities. These shaped parts adapt themselves optimally due to heating of the body to approx. 180 °C by expansion to the shape of the cavities.

As it is not possible to heat the body to this extent for a body repair, a different procedure has been laid down for this instance.

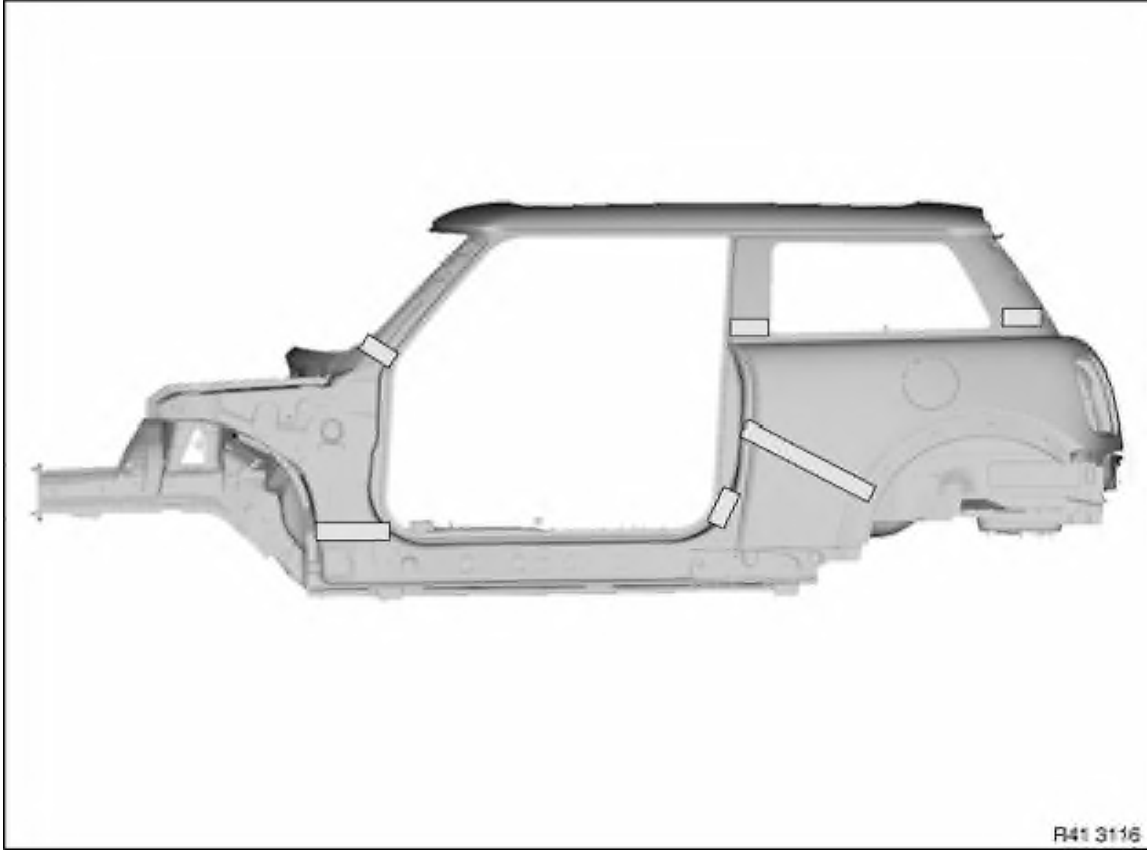

R41 3116