

**2002-07 GENINFO**

**Convertible - Overview - MINI**

**MINI CONVERTIBLE**

**R52 - CONVERTIBLE TOP SYSTEM**

**Purpose of the System**

The MINI Convertible is equipped as standard with a fully automatic convertible top on the MINI COOPER and MINI COOPER S.

The convertible top features an integrated sliding roof function (folding roof). A manually operated convertible top is not available. There is also no hardtop.

The fully automatic convertible top is folded down in the form of the letter Z. The convertible top consists of mechanical, hydraulic, and electric components that move the convertible top.



**Fig. 1: Fully Automatic Convertible Top**  
Courtesy of BMW OF NORTH AMERICA, INC.

**System Components**

The convertible top system used on the MINI is comprised of three major groups:

- Mechanical Components
- Hydraulic Components
- Electric Components

#### **Mechanical Components**

The mechanical components consist mainly of the convertible top frame, the canvas cover and the glass rear window.

#### **Convertible Top Frame**

The convertible top frame with its various brace sections and pillars forms the basic structure of the convertible top. No repair procedures are planned for the convertible top frame. If damaged, the complete convertible top frame must be replaced.

The convertible top cover with the integrated glass rear window can be replaced, however, replacement of the rear window itself is not possible.

The sections of inner headliner can be replaced individually. Likewise, all tensioning parts, seals, trim strips and operating cables for the sliding roof are available as spare parts.

**Convertible Top Frame**



**Fig. 2: Convertible Top Frame**  
 Courtesy of BMW OF NORTH AMERICA, INC.

**Hydraulic Components**

The hydraulic system consists of a hydraulic unit, two hydraulic cylinders, and the hydraulic lines. The system operates at pressures of up to 140 bar.

The hydraulic unit is made up of the motor driven pump as well as the oil reservoir. The direction of oil flow can be reversed by changing the polarity of the electric motor that drives the pump. The hydraulic cylinders consequently extend and retract.

The convertible top is folded down when the hydraulic cylinders are extended and closed when the hydraulic cylinders retract.

After topping up the oil reservoir with hydraulic oil (e.g. after repairs) particular care must be taken to ensure that the transparent reservoir is completely full. Only use MINI approved oil for this purpose. It is not necessary to bleed the hydraulic cylinders. The system is self-bleeding by operating the convertible top several times.



**Hydraulic Unit with Reservoir**

**Fig. 3: Hydraulic Unit With Reservoir**  
Courtesy of BMW OF NORTH AMERICA, INC.



**Hydraulic piston1**

**Fig. 4: Hydraulic Piston1**  
Courtesy of BMW OF NORTH AMERICA, INC.



Hydraulic Unit Mounted

**Fig. 5: Hydraulic Unit Mounted**  
Courtesy of BMW OF NORTH AMERICA, INC.



Hydraulic piston2

**Fig. 6: Hydraulic Piston2**  
Courtesy of BMW OF NORTH AMERICA, INC.

Convertible Top Hydraulic Circuit

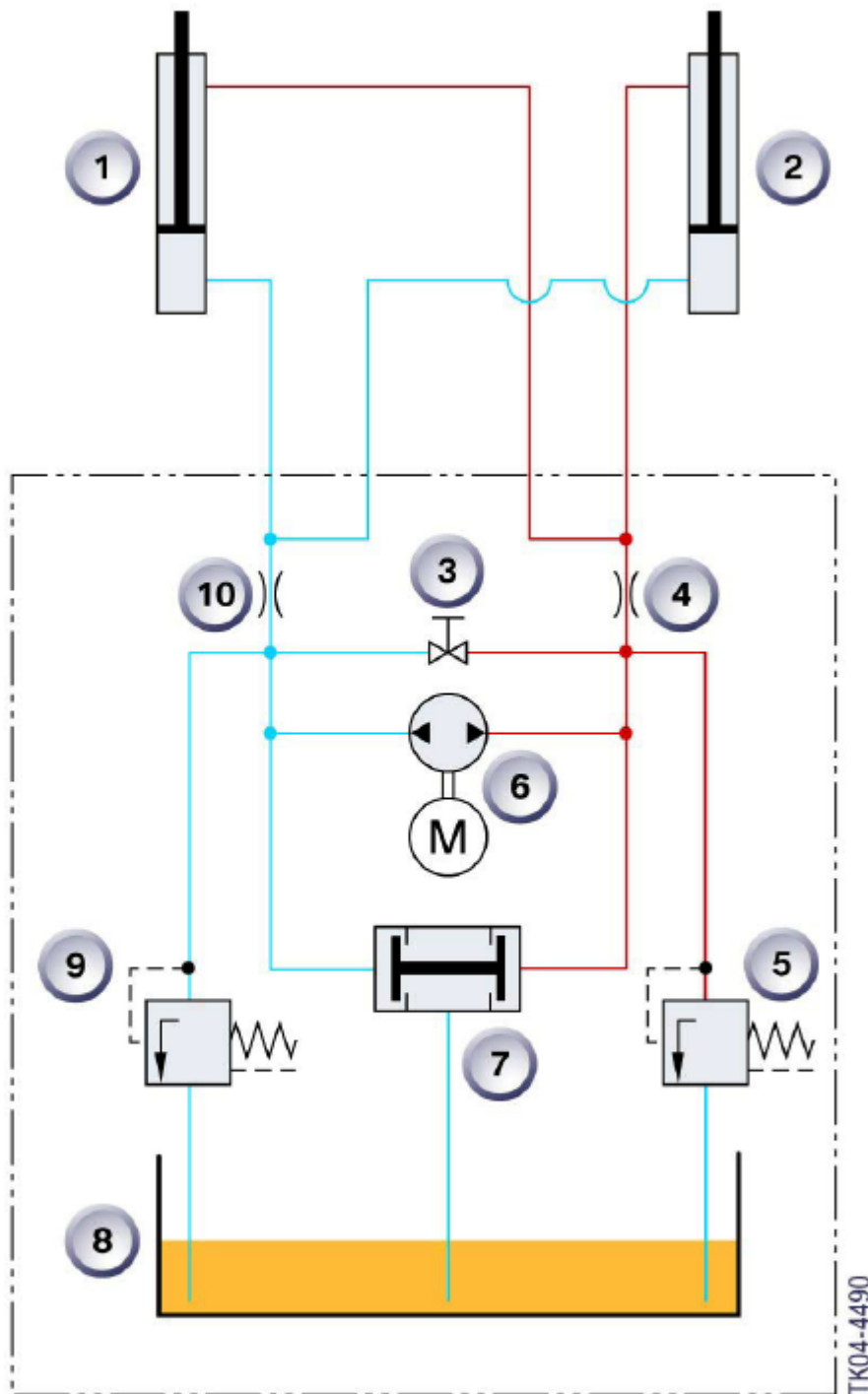

- |                                  |                          |
|----------------------------------|--------------------------|
| 1. Hydraulic Cylinder, Left      | 6. Electromagnetic Pump  |
| 2. Hydraulic Cylinder, Right     | 7. Change Valve          |
| 3. Valve for emergency operation | 8. Oil Reservoir         |
| 4. Throttle, Right               | 9. Pressure Relief Valve |
| 5. Pressure Relief Valve         | 10. Throttle, Left       |

TK04-4490

**Fig. 7: Convertible Top Hydraulic Circuit Diagram**  
 Courtesy of BMW OF NORTH AMERICA, INC.

**Electrical Components**

The electrical components consist of the convertible top module (CVM 4), the body controller (BC1), the instrument cluster (IKE), the heated rear window (HHS), a tensioning hoop signal generator, five Hall sensors, two microswitches and the electric motor to open the latch hooks and operate the sliding/folding roof.

**Convertible Top Module (CVM 4)**

The CVM 4 controls and monitors the fully automatic convertible top.

The following conditions must be met in order to fold down the convertible top:

- Side windows opened by BC1
- Tensioning hoop is down and locked
- Rear window shelf in bottom position
- Vehicle stationary



**Convertible Top Module**

**Fig. 8: Convertible Top Module (CVM 4)**  
 Courtesy of BMW OF NORTH AMERICA, INC.

**Body Controller (BC1)**

The BC1 features the characteristic functions of a general module. It controls the power windows (front and rear), central locking, anti-theft alarm system and electric load cutout. It is connected to the CVM 4 via the K-bus.

The BC1 is responsible for lowering the windows in connection with convertible top operation. By correspondingly actuating the power window motors, the BC1 ensures the windows are lowered and raised when necessary.

## 2006 MINI Cooper

2002-07 GENINFO Convertible - Overview - MINI

When closing the windows, the rear windows are raised first followed by the front windows until all windows are closed. There is no anti-trapping circuit.

### **Instrument Cluster (IKE)**

The instrument cluster calculates the driving speed value and makes it available to the CVM 4. This function is important for opening the folding roof (< 75 mph) and actuating the convertible top (< 2.48 mph).



# 2006 MINI Cooper

2002-07 GENINFO Convertible - Overview - MINI

## Convertible Top Module Schematic

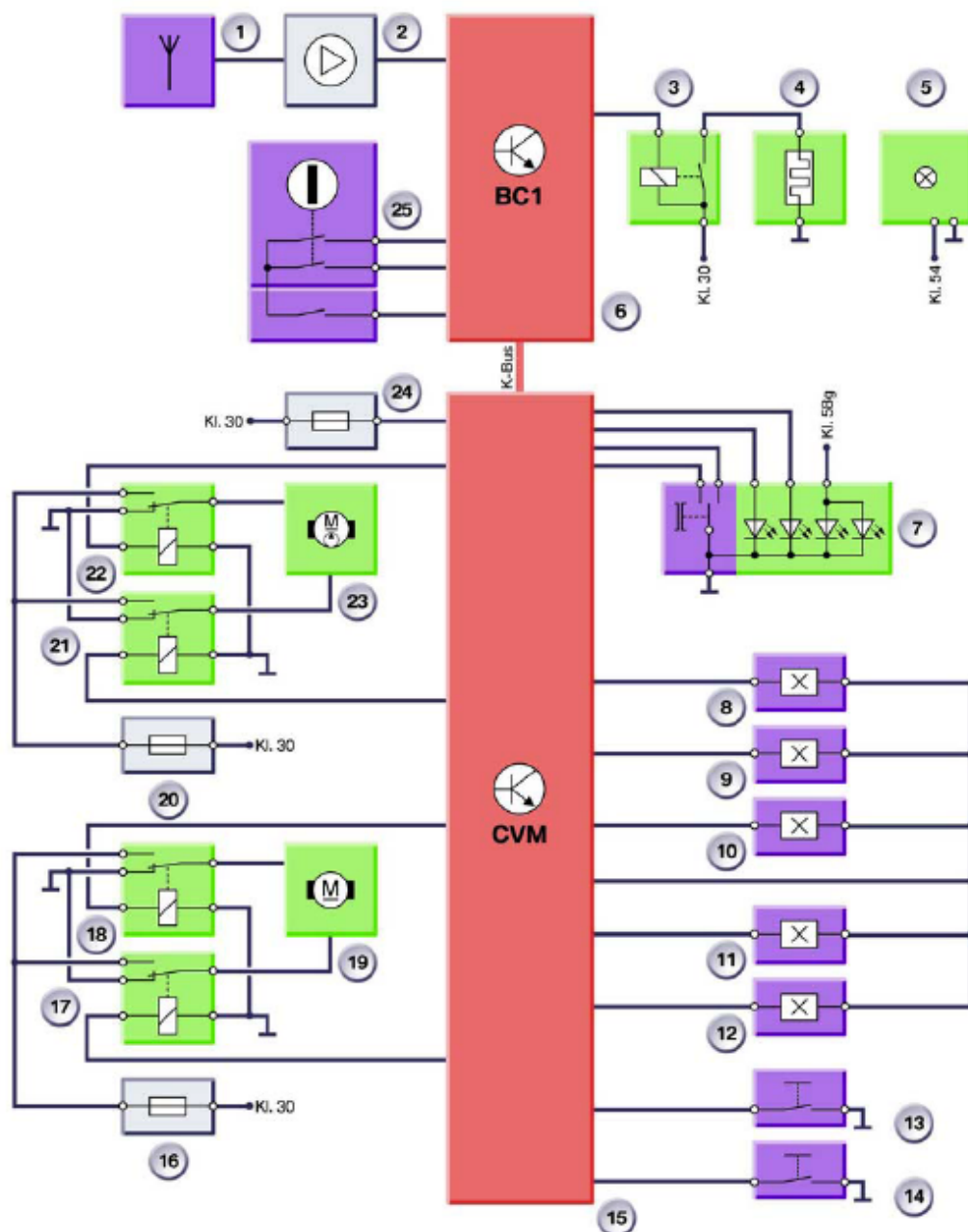

- |                                |                                    |                                    |
|--------------------------------|------------------------------------|------------------------------------|
| 1. Antenna                     | 10. Hall Sensor                    | 18. Relay, Elec. Motor             |
| 2. Antenna Amplifier           | 11. Hall Sensor                    | 19. Electric Motor                 |
| 3. Relay, Rear Window Defogger | 12. Hall Sensor                    | 20. Fuse FL3 40A                   |
| 4. Rear Window Defogger        | 13. Microswitch, Tensioning Hoop   | 21. Relay, Hyd. Motor              |
| 5. 3rd Brake Light             | 14. Microswitch, Rear Window Shelf | 22. Relay, Hyd. Motor              |
| 6. BC1                         | 15. CVM                            | 23. Hydraulic Pump                 |
| 7. Switch, Convertible Top     | 16. Fuse F15 20A                   | 24. Fuse F3 5A                     |
| 8. Hall Sensor                 | 17. Relay, Elec. Motor             | 25. Microswitch, Drivers Door Lock |
| 9. Hall Sensor                 |                                    |                                    |

**Fig. 9: Convertible Top Module Schematic**  
Courtesy of BMW OF NORTH AMERICA, INC.

**Rear Window Defogger(HHS)**

The rear window defogger (rear window heating) is controlled via the heating control panel and BC1. The rear window defogger is activated by the BC1 (via ground controlled relay) only when the convertible top is closed. The BC1 receives information on the position of the convertible top from the CVM 4 via the K-bus.

**Electric Motor**

The electric motor with gear unit and spirals is located in the roof console. It opens and closes the sliding roof and locks and unlocks the convertible top at the windshield cowl.



**Fig. 10: Electric Motor**  
Courtesy of BMW OF NORTH AMERICA, INC.

**Tensioning Hoop Signal Generator**

The tensioning hoop signal generator is a mechanical contact designed as a make contact to ground. It is closed when the bottom tensioning hoop is locked. This is the pre-requisite for convertible top movement in both directions.

**Hall Sensors and Microswitches**

The Hall sensors and microswitches inform the CVM 4 of the position of the convertible top and the sliding roof as well as the position of the rear window shelf and tensioning hoop.

**Convertible Top and Rear Window Switches**

The control switches for the convertible top are located on the front cowl area. The window switches are directly wired to the BC1 and the convertible top switches with LED are directly wired to the CVM4.

## 2006 MINI Cooper

2002-07 GENINFO Convertible - Overview - MINI

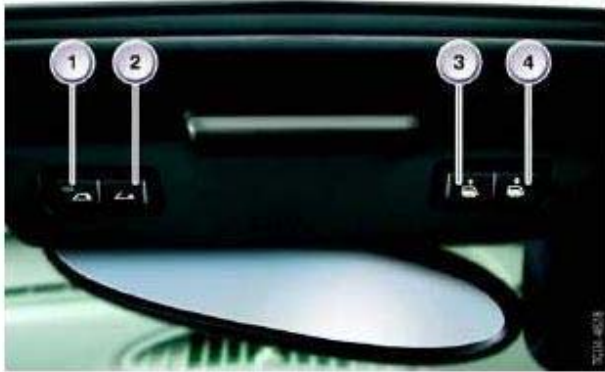

1. Convertible Top "Close" Button
2. Convertible Top "Open" Button
3. "Close" Side Window Button
4. "Open" Side Window Button

**Fig. 11: Convertible Top And Rear Window Switches**  
Courtesy of BMW OF NORTH AMERICA, INC.

## 2006 MINI Cooper

2002-07 GENINFO Convertible - Overview - MINI

### Convertible Top Sensor Locations

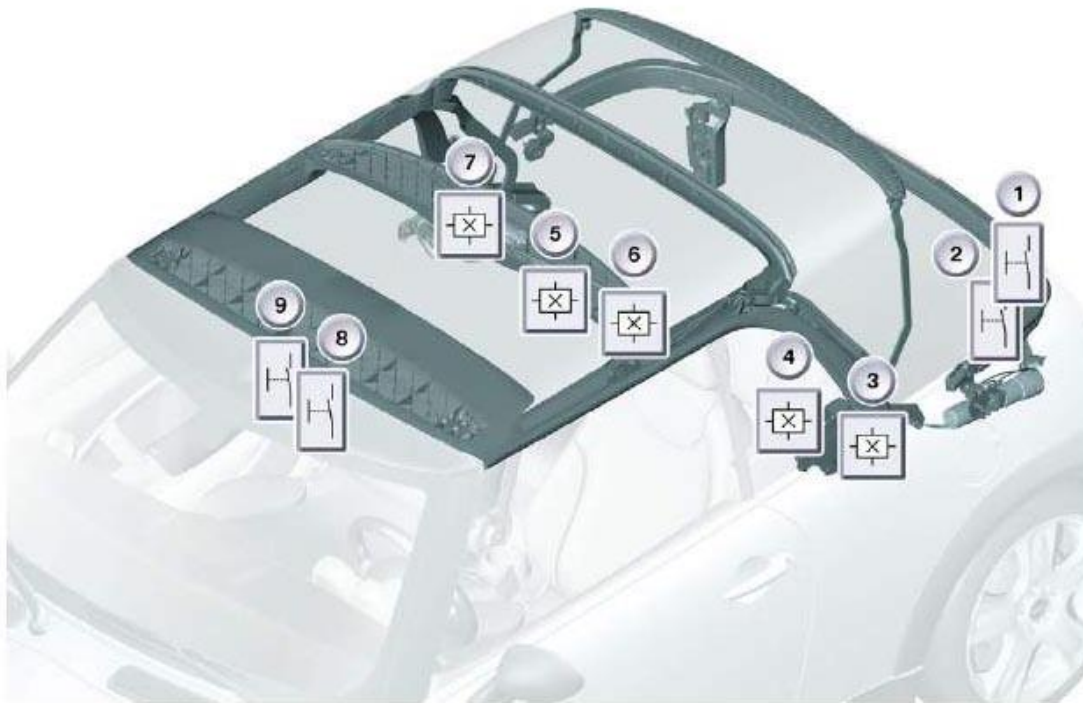

1. Microswitch	Closed Open	Convertible Top Tensioning Hoop Locked Convertible Top Tensioning Hoop NOT Locked
2. Microswitch	Closed Open	Rear Window Shelf in Bottom Position Rear Window Shelf NOT in Bottom Position
3. Hall Sensor	Energized Not Energized	Main Pillar completely folded down Main Pillar NOT completely folded down
4. Hall Sensor	Energized Not Energized	Main Pillar completely Raised Main Pillar NOT completely Raised
5. Hall Sensor	Energized Not Energized	Sliding Roof Opened, Latch locked Sliding Roof NOT Opened, Latch locked
6. Hall Sensor	Energized Not Energized	Sliding Roof completely Opened, Latch Unlocked Sliding Roof NOT in end position
7. Hall Sensor	Energized Not Energized	Sliding Roof not in end position, NOT Closed Sliding Roof completely Closed
8. Microswitch (Push-Button)	Closed Open	Convertible top "Open" Pressed Convertible top "Open" NOT Pressed
9. Microswitch (Push-Button)	Closed Open	Convertible top "Close" Pressed Convertible top "Close" NOT Pressed

**Fig. 12: Convertible Top Sensor Locations**  
 Courtesy of BMW OF NORTH AMERICA, INC.

### Convertible Top Operating Principle



**Fig. 13: Convertible Top Operating Principle**  
Courtesy of BMW OF NORTH AMERICA, INC.

### **Opening the Top**

A signal is sent to the CVM when, with the convertible top closed, the button to open the convertible top is pressed. The CVM activates the electric drive motor in the roof console.

The motor opens the sliding roof (folding roof). A signal is again sent to the CVM if the button is released and then pressed again in open direction.

The CMV then sends a signal to the BC1, which activates the electric drive motors to lower the side windows.

The next procedures cannot take place before the CVM has checked that the rear window shelf (via microswitch) and the tensioning hoop are in the correct position (also via microswitch). The CMV also monitors the vehicle speed (received from the instrument cluster). If the vehicle speed is greater than 2.5 mph the top operation stops.

The CVM then sends a signal to the drive motor in the roof console. In response, the drive motor opens the catch hooks. The sensors (Hall sensors) detect this status and signal it back to the CVM.

The CVM then activates the drive motor for the hydraulic pump which folds the convertible top over the luggage compartment. A pump "after running" period ensures the convertible top is firmly pressed together. A sensor detects this status and signals it to the CVM, which in turn, switches off the drive motor of the hydraulic pump.

If the button remains pressed, the BC1 then raises the side windows. The LED in the push-button flashes if one of the preconditions is not met.

Initially the sliding roof (folding roof) slides open by pressing and holding the push-button on the cowl panel in open direction. The button must then be released and pressed again. The side windows are now lowered.

The convertible top is then opened and folded down on the rear window shelf. The lowered side windows are

raised again if the button remains pressed (for longer than 2 s).

#### **Closing the Top**

Initially, the side windows are lowered when the button is pressed in "Close" direction. The convertible top is then closed and locked. If the button remains pressed, the sliding roof (folding roof) closes and shortly after the side windows are raised.

#### **Convenience Feature**

The system also features an auto remote opening and closing function. The BC1 sends the "auto remote close" signal to the CVM when the driver's door lock is turned to the right and held in that position. Turning the key to the left signals "auto remote open" to the CVM.

"Auto remote open" is also possible via the remote control. However, "auto remote close" is not possible via the remote control.

The convertible top can also be operated via the central lock button (CDL switch) by holding the toggle switch in the unlock position. This signal is sent via the BC1 to the CVM.

#### **Emergency Operation**

The convertible top can also be operated manually if it cannot be closed by pressing the button.

In this case, emergency operation means closing the convertible top. The convertible top should never be opened in the event of system failure unless the top is being serviced at an approved MINI Service Center.

Without hydraulic "pressure" in the lines, the folded top is not "locked" when in the open position. Damage may result.

#### **Emergency Closing Procedure**

(Service opening in reverse order)

- Access the hydraulic unit located in the left rear of the cargo area.
- Using the hexagon wrench from the vehicle tool kit, turn the corresponding screw (1) counter-clockwise by one and a half turns.

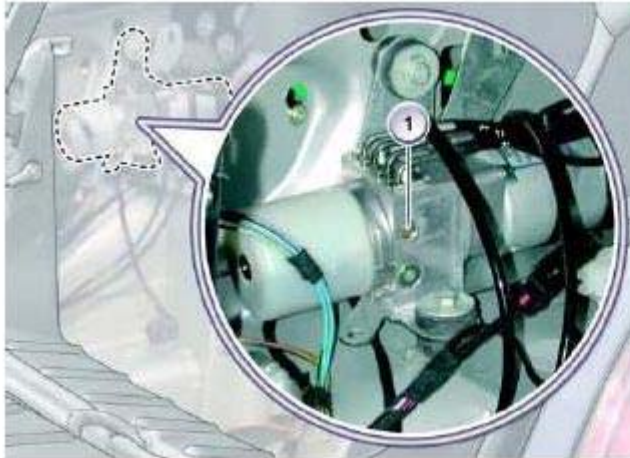

**Hydraulic Unit Location**

1. Pressure relief screw.

**Fig. 14: Hydraulic Unit Location**

Courtesy of BMW OF NORTH AMERICA, INC.

- Grasp the convertible top with both hands at the guide rails.
- Lift out simultaneously on both sides and swivel forward to the cowl panel.



**Fig. 15: Grasp Convertible Top With Both Hands At Guide Rails**

Courtesy of BMW OF NORTH AMERICA, INC.

- Use a screwdriver to lever out the cover on the roof console
- Fit the hexagon wrench in position and push up the clutch
- Turn hexagon wrench in clockwise direction to close the convertible top



**Fig. 16: Turning Hexagon Wrench In Clockwise Direction**  
Courtesy of BMW OF NORTH AMERICA, INC.

### **Replacing Convertible Top Cover**

It is possible to replace the convertible top cover (canvas w/glass) on the R52 without removing the entire mechanism from the vehicle.

### **Replacing Third Brake Lamp**

The third brake lamp is installed into the rear bow area and can be replaced separately.

### **Adjustments**

Various adjustments can be made to the convertible top of the R52 MINI Convertible.

- For instance, spacer nuts can be used to adjust the convertible top seals with respect to the front side windows (newer tops use shims).
- The rear side windows can also be adjusted to the seals.
- The front side windows can also be adjusted to the convertible top seals (as known from the Saloon).
- The convertible top itself should not require any adjustments. The threaded connections are fixed.
- The operating cables for the sliding roof functions can be adjusted and replaced.

Repair instructions pertaining to these adjustments can be found in MINI TIS.