

# ORIGINAL MINI ACCESSORIES. INSTALLATION INSTRUCTIONS.



## MINI Sport Stripes Retrofit

MINI One (R50)

MINI Cooper (R50)

MINI Cooper S (R53)

MINI One Convertible (R52)

MINI Cooper Convertible (R52)

MINI Cooper S Convertible (R52)

### Installation time

The installation time for the front/rear retrofit kit is approx. 0.75 hours.

The installation time for the roof retrofit kit is approx. 0.5 hours.

The installation times may vary depending on the car's equipment.

### Important information

These installation instructions are primarily designed for use within the MINI dealership organisation and by authorised MINI service companies.

In any event the target group for these installation instructions is specialist personnel trained on MINI cars with the appropriate specialist knowledge.

All work must be completed using the latest MINI repair manuals, wiring diagrams, servicing manuals and work instructions, in a rational order, using the prescribed tools (special tools) and observing current health and safety regulations.

### If you experience installation or function problems, restrict troubleshooting to approx. 0.5 hours for mechanical work and 1.0 hour for electrical work.

To avoid unnecessary extra work and/or costs, send an inquiry straight away to the technical parts support team via the Aftersales Assistance Portal (ASAP).

Quote the following information:

- Chassis number,
- Retrofit kit part number,
- A detailed description of the problem,
- Any work already carried out.

Do not archive the hard copy of these installation instructions, since daily updates are provided via ASAP!

All pictures show LHD cars; proceed accordingly on RHD cars.

### Pictograms

 Denotes instructions that draw your attention to dangers.

 Denotes instructions that draw your attention to special features.

◀ Denotes the end of the instruction or other text.

### **Installation information**

In order to achieve high bond strength, the vehicle must have a temperature of approx. 20°C. During the bonding and hardening process, the car must not be exposed to direct sunlight and must be parked in a completely wind-free location.

Clean the area to be used before adhering the strips. The areas being bonded must be completely dry, clean and free from wax or grease.

Before bonding, carefully remove the protective film from the decorative strips.

Fix in place the MINI Sport Stripes using the scraper while pulling off the backing paper.

At the points at which the MINI Sport Stripes have been laid around corners or edges, the drying time of 5-10 minutes must be strictly observed before bonding the strips around the edges. To accelerate the drying time, carefully heat the MINI Sport Stripes until they are just lukewarm using a hairdryer.

The vehicle must not be washed for 48 hours after bonding the film.

**As an option** for further enhancing the appearance, vehicles with navigation and all vehicles built after 10/2004 can have their roof-mounted aerial removed according to ISTA and also roof strip **a** with the small cut-out can be bonded (see section 6). Increased installation time through removal of the roof-mounted aerial is not included in the installation time indicated on the first page.

### **Special tools required**

Details of the special tools required can be found in the relevant ISTA repair manual.

### **Ordering instructions**

The Sport Stripes retrofit is not a retrofit kit. All the parts required for the Sport Stripes retrofit must be ordered separately for the appropriate car version and year of manufacture (for part number and instructions, see EPC).

## Table of contents

Section	Page
1. Parts list for retrofit kit .....	4
2. Preparatory work .....	5
3. Bonding of bonnet MINI Sport Stripes .....	6
4. Bonding the tailgate MINI Sport Stripes .....	8
5. Bonding the MINI Sport Stripes around the edges .....	9
6. Bonding the MINI Sport Stripes on the roof .....	10
7. Concluding work and coding .....	12

## 1. Parts list for retrofit kit

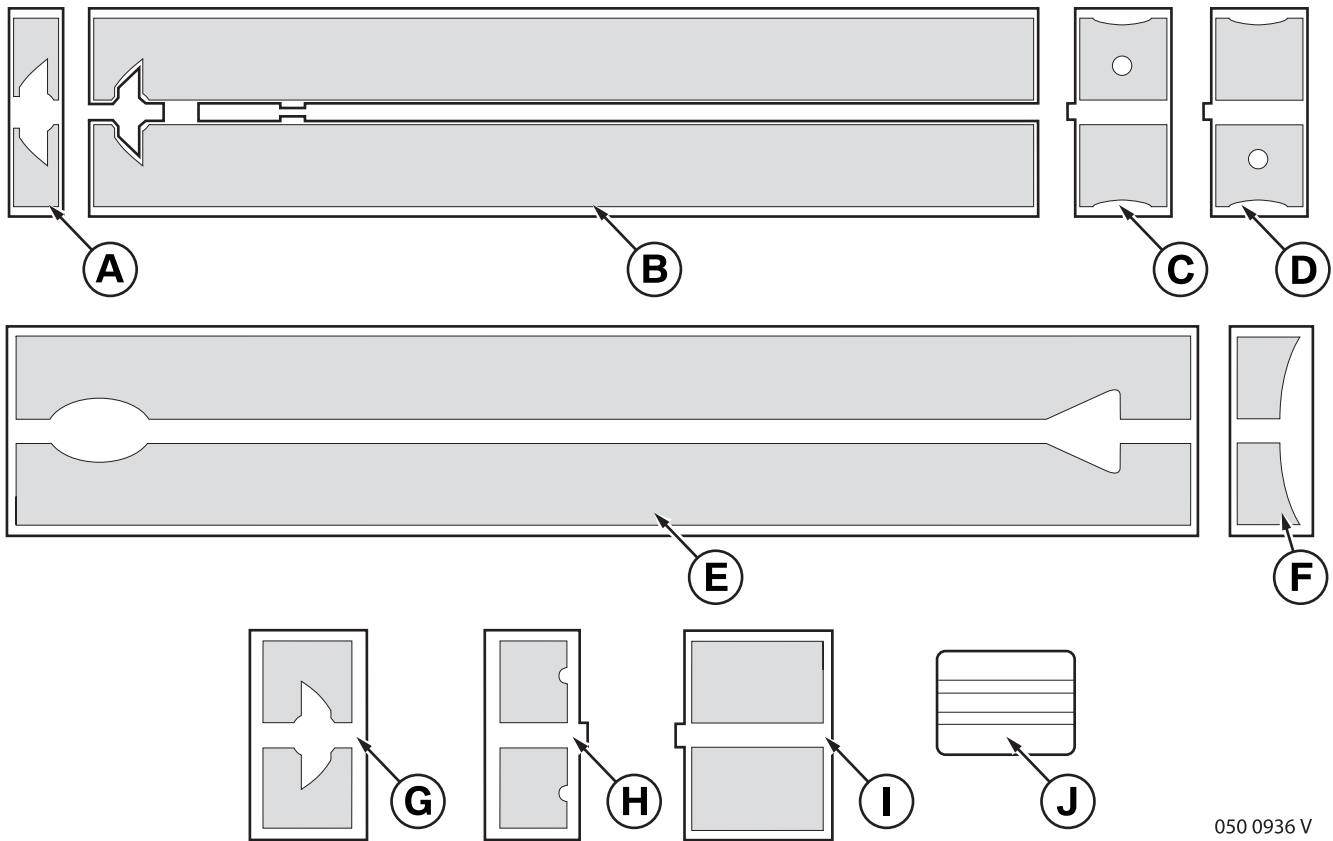

050 0936 V

### Legend

- A** Bonnet emblem decal strip (only for Cooper S, Cooper S Convertible)
- B** Bonnet decal strip
- C** Ventilation grill decal strip (only for LHD vehicles)
- D** Ventilation grill decal strip (only for RHD vehicles)
- E** Roof decal strip
- F** Additional brake light decal strip
- G** Tailgate emblem decal strip
- H** Handle strip decal strip
- I** Number plate decal strip
- J** Scraper

## 2. Preparatory work

	ISTA No.
Conduct a brief test	---
Disconnect the negative battery connection	61 20 900
<b>The following components must be removed first of all</b>	
Rear number plate holder	---
<b>Only for Cooper S (R53) and Cooper S Convertible (R52):</b>	
Front ornamental grille centre	51 13 000

### 3. Bonding of bonnet MINI Sport Stripes

- ☐ Clean the areas to be bonded with a cleaning cloth and suitable cleaning agents. The painted surfaces must then be completely dry, clean and free from wax or grease.

The decal strips to be bonded into position are mounted on backing papers. The adhesive side of the decal strips is covered with protective film. ◀

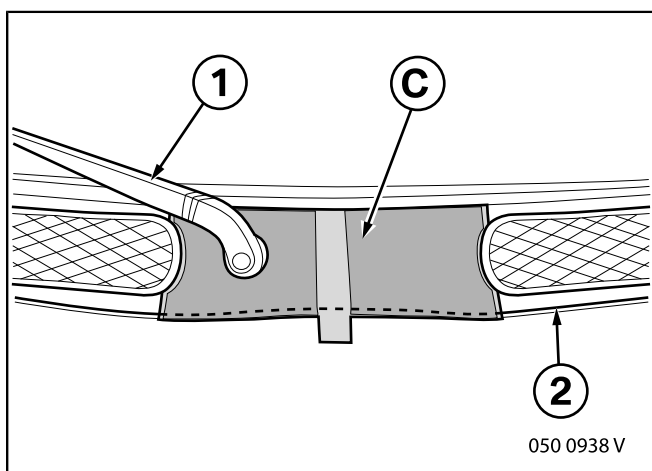

#### Bonding decal strip C:

- guide decal strip C over the wiper arm (1), ...
- stick it on and orient it using the wiper arm (1) and ...
- carefully smooth it on using the scraper.

- ☐ Decal strip C is bonded around the edge (2) once the tailgate decal strips have been installed. ◀

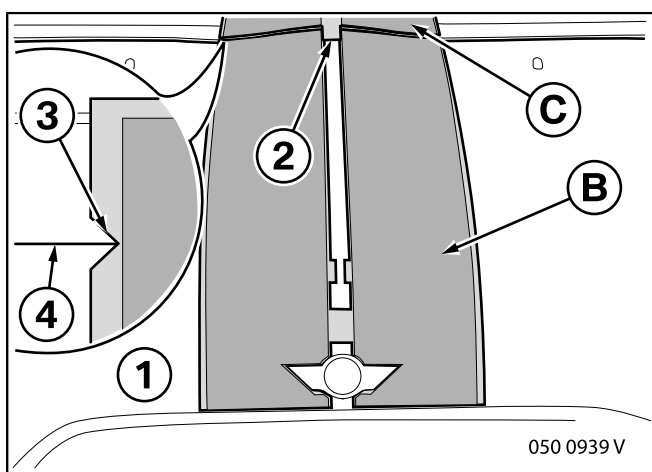

#### Only for One (R50), Cooper (R50), One Convertible (R52) and Cooper Convertible (R52): Bonding decal strip B:

- position decal strip B on the bonnet (1), ...
- while orienting it in the front on the MINI emblem and ...
- in the rear using the overlap (2), ...
- position the notch (3) on the edge of the bonnet (4) and ...
- carefully smooth it on using the scraper.

- ☐ Decal strip B is bonded around the edge (4) once the tailgate decal strips have been installed. ◀

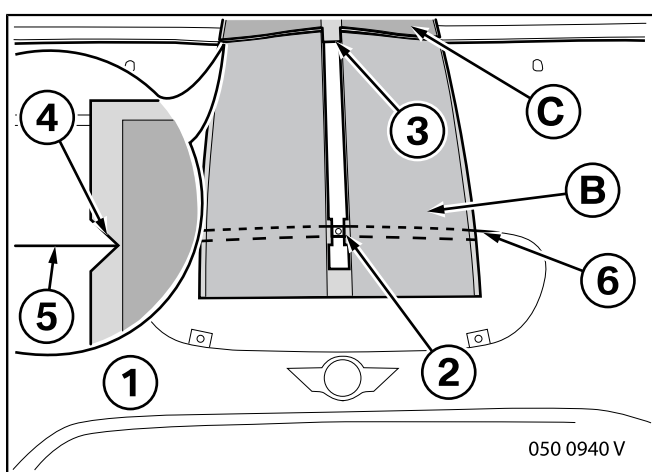

#### Only for Cooper S (R53) and Cooper S Convertible (R53): Bonding decal strip B:

- position decal strip B on the bonnet (1), ...
- in the front using the centring point (2) on the air inlet and ...
- in the rear using the overlap (3), ...
- position the notch (4) on the edge of the bonnet (5) and ...
- allow approx. 5 mm to protrude over the air inlet edge (6) and cut it off, and ...
- carefully smooth it on using the scraper.

- ☐ Front decal strip C is bonded around the edges (5) and (6) once the tailgate decal strips have been installed. ◀

### 3. Bonding of bonnet MINI Sport Stripes

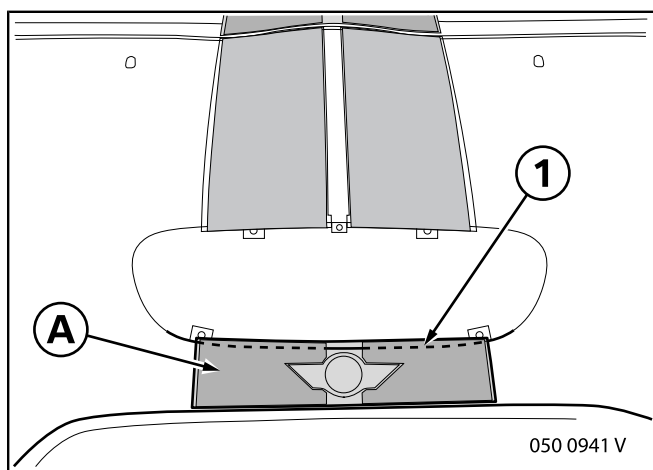

#### **Bonding of decal strip A on Cooper S (R53):**

- position decal strip A on the bonnet using the MINI emblem, then ...
- carefully smooth it on using the scraper.

▶ Decal strip A is bonded around the edge (1) once the tailgate decal strips have been installed. ◀

## 4. Bonding the tailgate MINI Sport Stripes

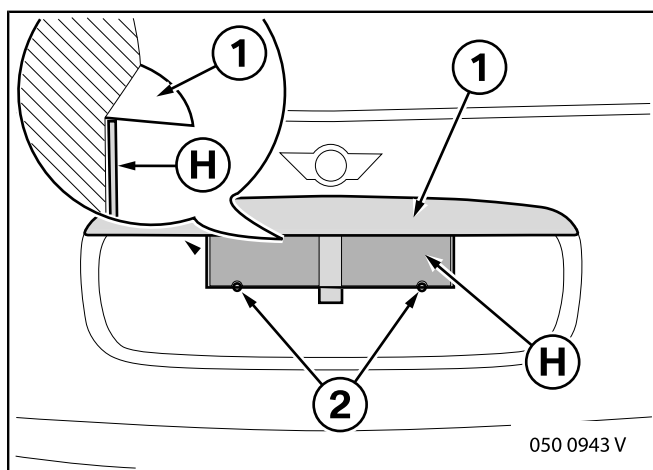

### Bonding decal strip H:

- position decal strip H under the handle strip (1), then ...
- push it to the edge of the handle strip (1) and orient it using the holes (2), then ...
- carefully smooth it on using the scraper.

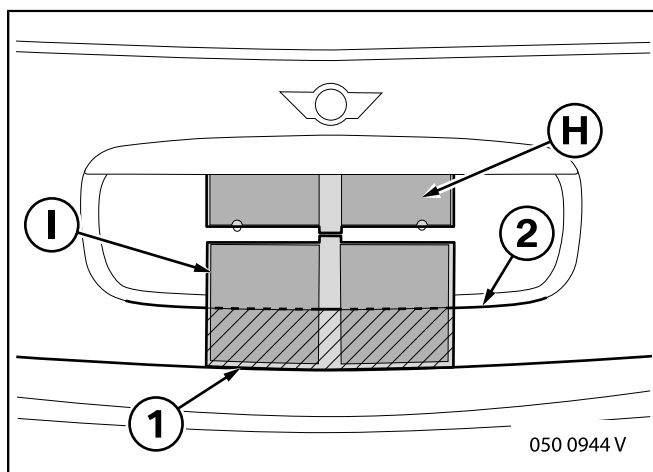

### Bonding decal strip I:

- position decal strip I beneath decal strip H, ...
- place the backing paper flush with the tailgate edge (1), ...
- orient it on the top using decal strip H, ...
- and carefully smooth on decal strip I using the scraper in the area marked with lines.

▶ Decal strip I is bonded in the number plate depression (2) at a later point in time. ◀

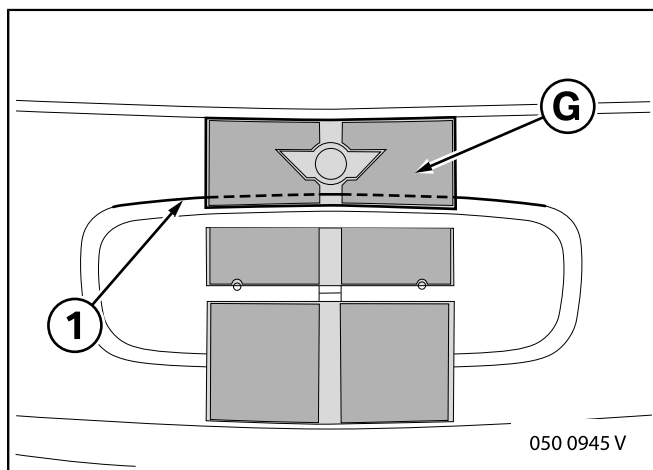

### Bonding decal strip G:

- Remove handle strip (tailgate) according to **ISTA No. 51 13 402** (do not pull off), ...
- position and orient decal strip G using the MINI emblem, then ...
- carefully smooth it on using the scraper.



## 5. Bonding the MINI Sport Stripes around the edges

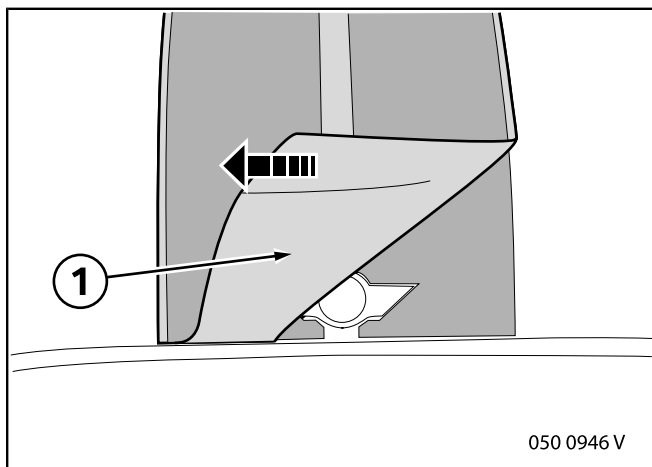

### Removal of backing papers from the bonnet:

- ▶ Make sure that the decal strips remain adhered to the car and cannot be moved. ◀
- Pull off the backing papers (1) from all decal strips at as flat of an angle as possible.

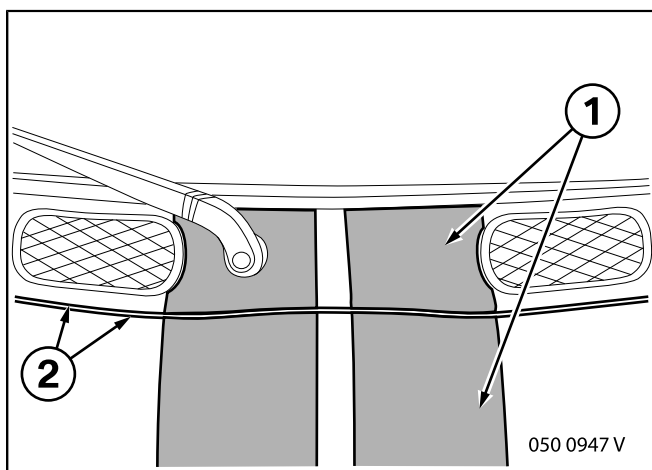

### Bonding the bonnet decal strips:

- Carefully bond the protruding parts around the edges (2).

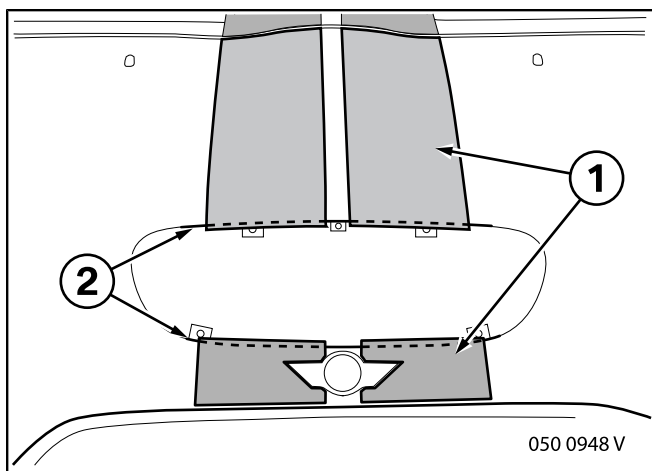

### Only for Cooper S (R53) and Cooper S Convertible (R53): Bonding the bonnet decal strips:

- Carefully bond the protruding parts around the edges (2).

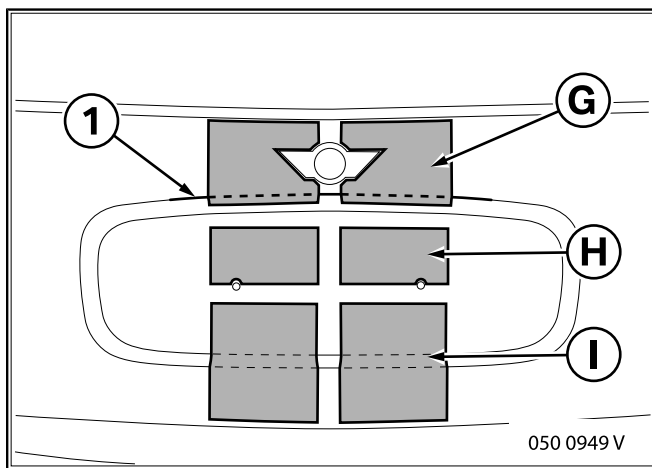

### For all cars: Bonding the tailgate decal strips:

- ▶ Make sure that the decal strips remain adhered to the car and cannot be moved.
- pull off the backing papers from decal strips G, H and I at as flat of an angle as possible, ...
- carefully bond decal strip I in the number plate depression.

## 6. Bonding the MINI Sport Stripes on the roof

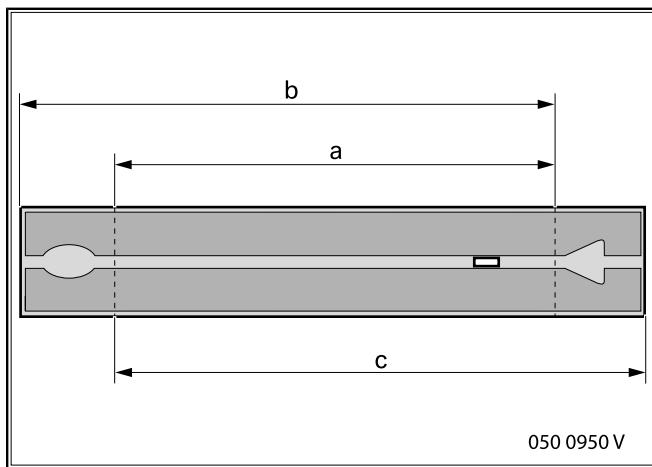

☒ A different section of roof decal strip **E** is used depending on the roof-mounted aerial version: ◀

- a for cars without navigation built before 10/2004,
- b for cars with navigation built before 10/2004,
- c for all cars built after 10/2004.

Roof decal strip **E** is trimmed during installation.

**As an option** for further enhancing the appearance, vehicles with navigation and all vehicles built after 10/2004 can have their roof-mounted aerial removed according to ISTA and also roof strip **a** with the small cut-out can be bonded. Increased installation time through removal of the roof-mounted aerial is **not** included in the installation time indicated on the first page.

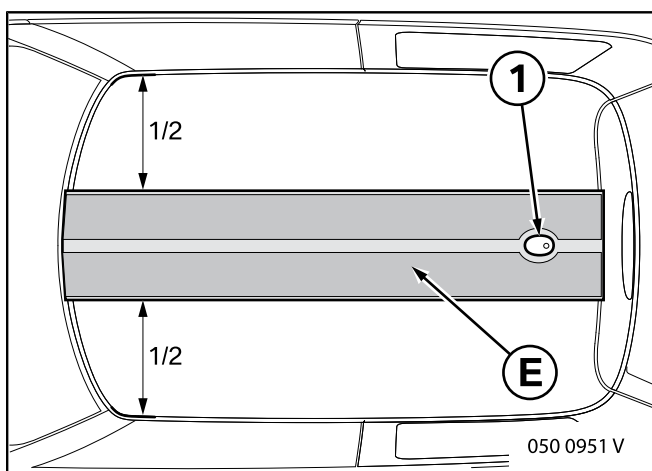

### Bonding decal strip **E**:

☒ For vehicles without navigation built before 10/2004, the roof-mounted aerial cover must be removed according to **ISTA No. 65 20 022**. ◀

- guide decal strip **E** over the roof-mounted aerial (1), ...
- orient it in the rear using the roof-mounted aerial, ...
- smooth decal strip **E** in place starting at the roof-mounted aerial and stroking towards the front, ...
- leave a protruding part of approx. 5 mm in the front and trim decal strip **E**.

☒ Decal strip **E** must first dry on for approx. 5-10 min before bonding around the edges. ◀

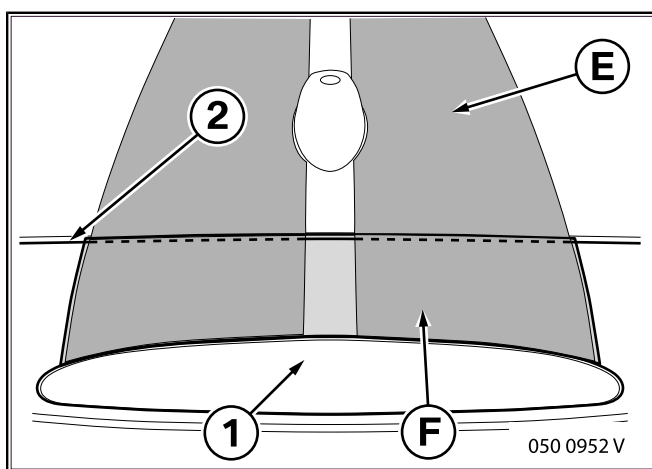

### Bonding decal strip **F**:

- position decal strip **F** on the tailgate, ...
- orient decal strip **F** such that ...
- it lies flush with the additional brake light (1) and ...
- protrudes approx. 5 mm at the tailgate edge (2), ...
- decal strip **F** must align with decal strip **E** and finally, ...
- carefully smooth it on using the scraper.

☒ Decal strip **F** must first dry on for approx. 5-10 min before bonding around the edges. ◀

## 6. Bonding the MINI Sport Stripes on the roof

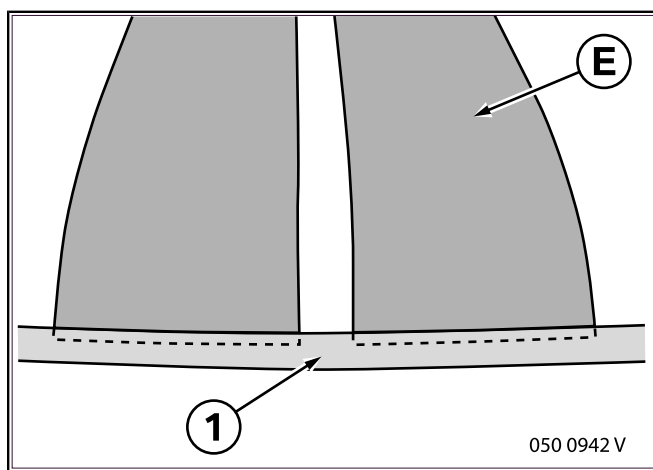

### Bonding decal strip E around the front edge:

- ▶ Carefully remove backing paper from the decal strips (see page 9, “Removing the backing paper”). ◀
- lift the window rubber frame (1) in the front, then ...
- carefully bond the protruding part in the front under the window rubber frame (1).

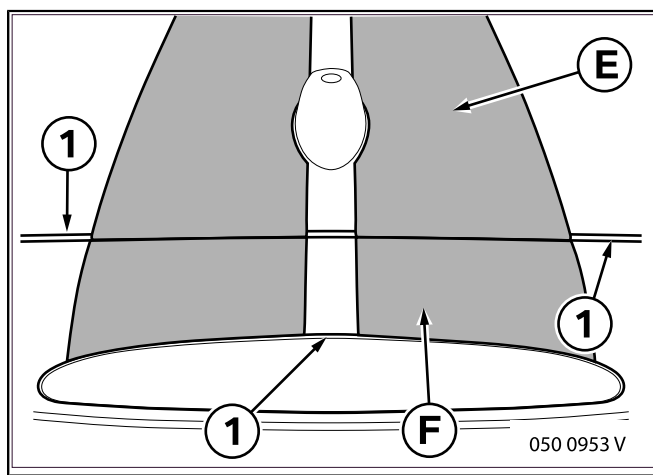

### Bonding decal strips E and F around the edges:

- ▶ Carefully remove backing paper from the decal strips (see page 9, “Removing the backing paper”). ◀
- Carefully bond the protruding parts around the edges (1).

## 7. Concluding work and coding

The retrofit system does not require programming/coding.

- Connect the battery
- If necessary, carry out a vehicle test using the ISTA system, and note, or work through, any errors that has been recorded
- Re-assemble the car