



**ZF GETRIEBE N.V. SINT-TRUIDEN**

*Description*

*Automatic Gearbox*

**VT1F**

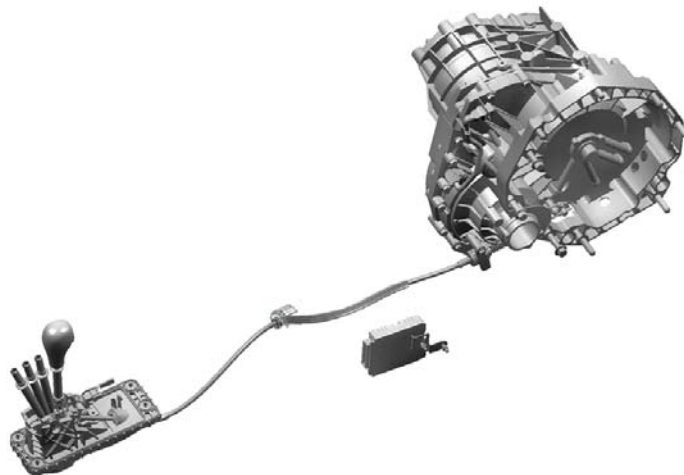

Davy Geuns

June 2003

## *Table of contents*

I.	General Description VT1F _____	4
1.	Introduction _____	4
2.	Conventional Autom. Transmission vs. Continuously Var. Transmission _	6
3.	Basic Principles of Continuously Variable Transmission _____	7
4.	Shift Positions _____	8
5.	Functionality in Park and Neutral _____	9
6.	Normal Operation _____	9
7.	Transmission Communication _____	10
8.	Related Car Components _____	10
	8.1 Centre Controle LEDs _____	10
	8.2 Instument Cluster Display _____	10
	8.3 Selector Lever Mechanics _____	10
	8.4 Torsional Damper _____	11
9.	Towing of the Vehicle _____	11
10.	Drain and Refill _____	11
II.	Transmission Layout _____	12
1.	Group One – Mechanical Torque Flow _____	13
	1.1 Planetary Gear Set _____	13
	1.2 Multiplate clutches _____	14
	1.3 Pulley and Steel Belt _____	15
	1.4 Pinion Shaft _____	16
	1.5 Differential _____	16
	1.6 Mechanical Operation _____	17
	1.6.1 Selector Lever in the Park or Neutral Position _____	17
	1.6.2 Selector Lever in the Drive Position _____	18
	1.6.3 Selector Lever in the Reverse Position _____	19
2.	Group Two – Control System _____	20
	2.1 Oil Pump _____	20
	2.2 Valves _____	21
	2.3 Pitot system _____	21
	2.4 Sensing Shoe _____	22
	2.5 Oil Temperature Sensor _____	22
3.	Group Three – External Connections _____	23
	3.1 Park / Neutral Switch _____	23
	3.2 Oil Cooler Locations _____	24
	3.3 Transmission Secondary Speed Sensor _____	25
	3.4 Selector Shaft _____	26
	3.5 Connector _____	26
III.	Strategies _____	27
1.	Behaviour in Specific Situations _____	27
	1.1 Idle when Drive is Selected _____	27

1.2	Take Off / Pulling Away	27
1.3	Light Throttle Acceleration in Drive or Sport	27
1.4	Kick Down in Drive or Sport	28
1.5	Emergency Stop	28
1.6	Reverse Running	28
1.7	Fault Mode	28
2.	CVT Software	29
3.	Transmission Reset and Reference	30
IV.	Adaptation Procedures	31

## Automatic Gearbox – VT1F

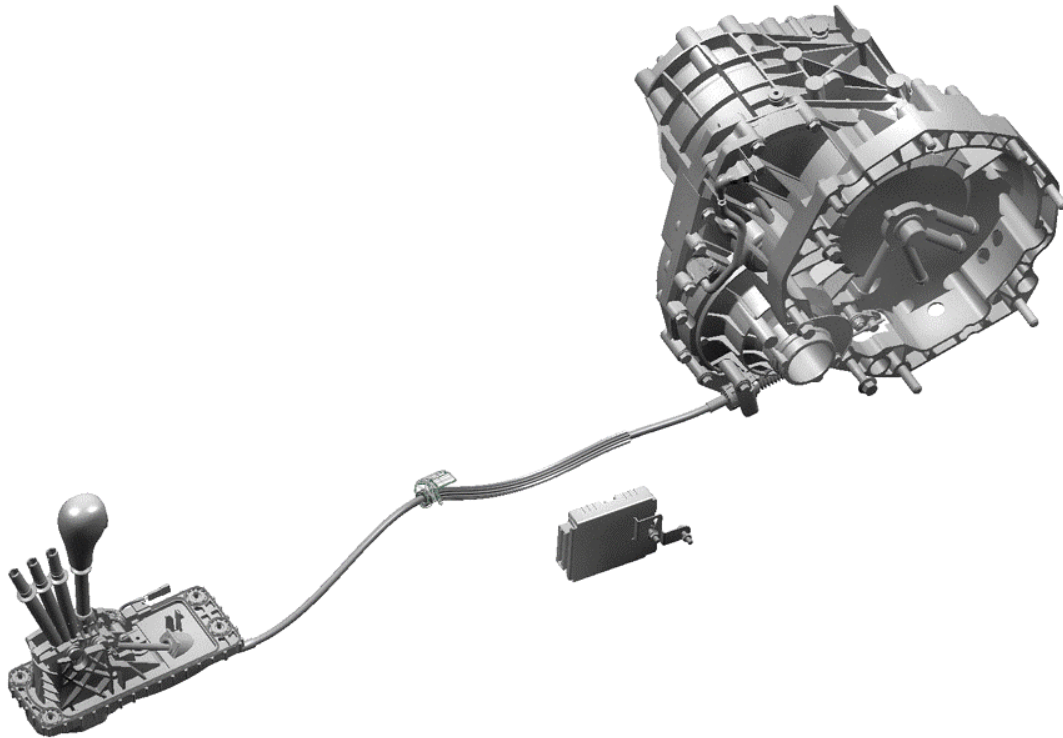

*Fig. 1: Gearbox and selector mechanism*

### I. General description VT1F

#### 1. Introduction

The stepless shifting pattern of the transmission provides a very comfortable drive, as well as having full vehicle performance, available at any time.

The advantages of using an automatic transmission of this type are:

- Low engine revolutions at constant speeds.
- Improved emission control/fuel consumption.
- Low noise, vibration and harshness levels.
- Smooth acceleration.
- Flexible driving on mountain roads.



*Fig. 2: CVT box*



*Fig. 3: Bell Housing*

## 2. Conventional Automatic Transmission vs. Continuously Variable Transmission.

In the figure below the variograms of a hand shifted or normal automatic transmission and the CVT are compared with each other. With the conventional automatic transmission, maximum 6 ratio's (gears) are available, but mostly even less. When the transmission upshifts, it has to follow the bold or dotted lines of the first image depending of the amount of throttle. With the CVT, the whole range of ratios between the Low and the Overdrive lines is available for shifting as shown in the second image.

The shift point of both transmissions is related to the amount of throttle. As more throttle is applied, the transmission upshifts at a higher engine speed. With the conventional transmission it is clear that the engine speed drops back when shifting to a higher gear. This is not the case with the CVT. The CVT will upshift at a constant engine speed, by moving the pulleys as explained in the next part. However, alternative shifting strategies are also possible. This can help to create a quicker acceptance by new CVT drivers.

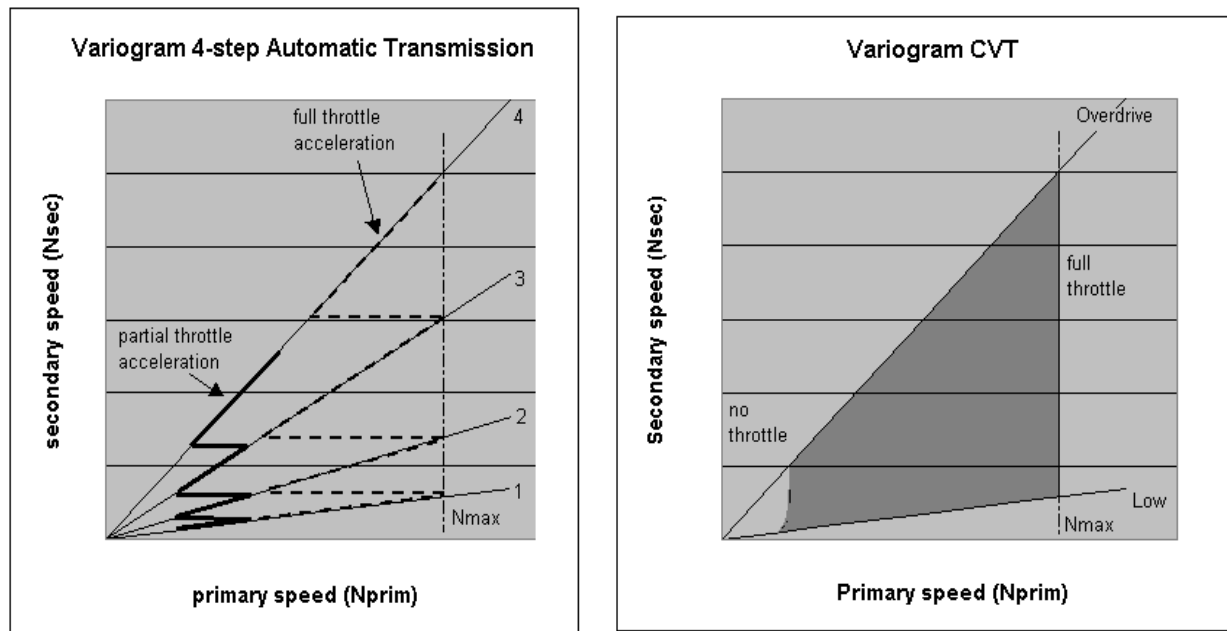

Fig. 4: Variogram 4 step automatic transmission and CVT Transmission.

### 3. Basic Principles of Continuously Variable Transmission

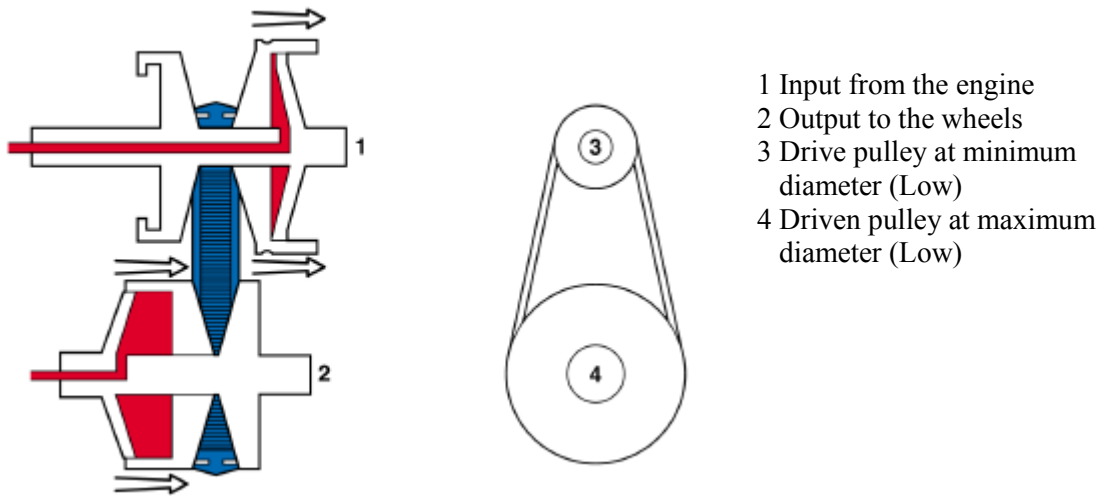

Fig. 5: Pulleys in low position

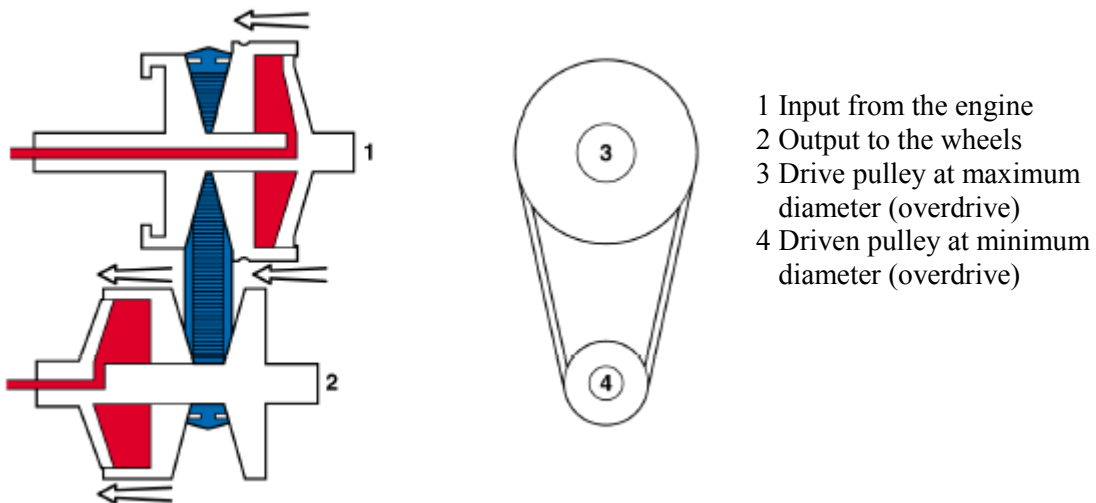

Fig. 6: Pulley positions in high ratio (overdrive)

Unlike conventional planetary automatic transmissions that provide a limited number of gear ratios, usually four, five or six, the CVT, as its name suggests, continuously varies the gear ratio. A low gear (low ratio) makes it easier to pull away from a rest position, the drive pulley diameter being relatively small, while the driven pulley diameter is large by comparison. The drive belt is used to transmit power and torque. As acceleration takes place it becomes possible to select a higher ratio by increasing the diameter of the drive pulley while, at the same time, decreasing the diameter of the driven pulley. This degree of change can be controlled to ensure that the most suitable ratio is provided.

The CVT uses a primary pulley and a secondary pulley. Both pulleys have one fixed half and one mobile half, controlled by hydraulic pressure. The position of the drive belt on the pulleys will determine the ratio. If the mobile half of the pulley is close to its opposite half then the drive belt is forced to travel around the outer circumference. When the pulley is open wide then this circumference is reduced. The primary and secondary pulley mobile halves are

diagonally opposed so when the drive belt diameter is reduced on the primary pulley, it increases on the secondary pulley.

To pull away, a low ratio is required. To provide this, the primary pulley is open, allowing the drive belt to sit down into the pulley and forcing it to run around the outer of the closed secondary pulley. As vehicle speed increases, a higher gear ratio is required. To do this, the primary pulley gradually moves towards its fixed partner, increasing the pulley circumference. At the same time the secondary pulley is forced apart reducing pulley diameter, therefore creating a higher gear ratio. An overdrive ratio is obtained when the primary pulley is fully closed and the secondary pulley is fully open. The secondary pulley is now forced to rotate approximately two and a half time for every turn of the primary pulley.

#### 4. Shift Positions.

Possible shift positions for the VT1F are **Park**, **Reverse**, **Neutral**, **Drive** and **Sport/Manual** position (other shifter lay outs are also possible of course, for instance with an L position).

In the **Drive** position, the car will move forwards in standard CVT mode. The engine speed will be limited to approximately 4500 rpm unless kick down is used by fully depressing the throttle pedal when the engine speed will rise to approximately 5500 rpm. Of course other calibrations are also possible.

In the **Manual/Sport** position, the car will move forwards in CVT sport mode. The engine speed will be limited to approximately 5000 rpm unless kick down is used by fully depressing the throttle pedal when the engine speed will rise to approximately 5500 rpm. Again, other calibrations are also possible.

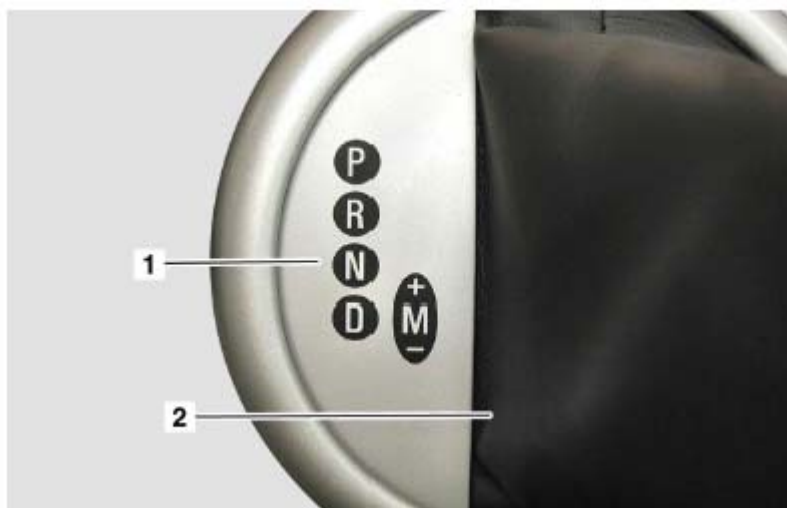

1. Illuminated gear position
2. Gear selector lever

Fig. 7: VT1F gear lever & M+ /-

In **Sport** position the transmission will be tuned in a different way than in **Drive** mode. The transmission will upshift at a higher engine speed, providing more sportive driving. The Sport driving calibration is designed to be more responsive to driver command, but will be less refined than the D position.



If the gear shift lever is moved into the 'Plus' or 'Minus' position from **Manual/Sport**, the system will change into **Manual** mode. The transmission then works with 6 (or more) "gear" ratios. The system will select a gear appropriate to road and driving conditions. To change up a gear, the driver must move the gear lever to the 'Plus' position. To change down, the driver must move the gear lever to the 'Minus' position.

If the CVT software decides that a shift might cause damage to the transmission, such as attempting to shift to 1st gear at 100 km/h, the gear change will be prevented. If the driver does not shift up, the next gear will be automatically selected when the engine revolutions reach approximately 6000 rpm. Equally, if the driver does not shift down when reducing vehicle speed, the system performs the down-change automatically thus ensuring the transmission is in the appropriate gear.

## 5. Functionality in Park and Neutral

The engine can only be started in **Neutral** or **Park**, as with any automatic transmission.

A spring and cone operated pawl mechanically locks the secondary pulley when the selector lever is moved to the **Park** position. If the lever is set in the **Park** position when the vehicle has a higher speed, the pawl will rattle without engaging **Park**. It will not engage until the vehicle speed drops below approximately 5 km/h.

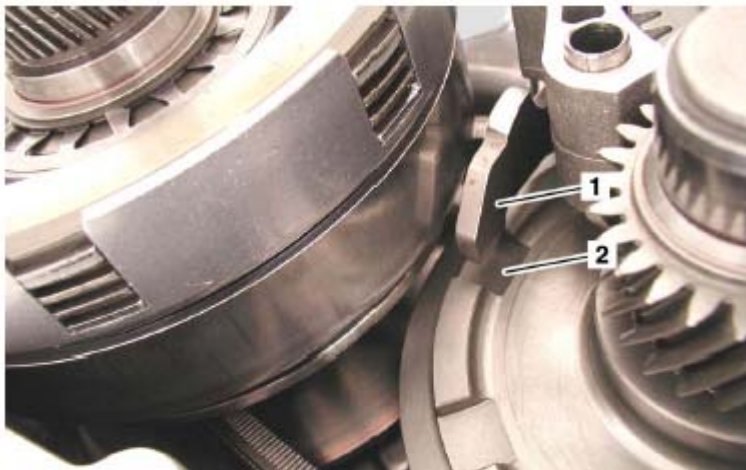

1. Parking pawl
2. Secondary pulley

*Fig. 8: Parking lock*

## 6. Normal Operation

The operation of the transmission, during driving, has no comparison with that of a conventional automatic transmission. All kinds of tunings are possible. A possible tuning is that if the accelerator pedal is depressed sharply, the engine rpm will rise considerably more than in relation to the speed of the vehicle. This functionality is normal for a CVT but may surprise drivers not familiar with this type of transmission. Other tunings / variograms are also possible, for example tunings that are closer to that of a conventional automatic transmission.

## 7. Transmission Communication

The VT1F has electronic components to control the gear ratios, the clamping force on the belt and the clutch pressure. The location of the components that form the stepronc transmission vary depending upon vehicle installation.

There are different options for the position of electronic components in the transmission. For example, the control methods associated with the transmission can be run as part of the software in the ECU. The CVT software in the ECU receives inputs from the main sensors of this system, communicates with the gearbox interface unit (GIU) to control the transmission, accepts driver inputs and provides information to the driver via the instrument cluster. With this example the software is located in the ECU, while the drivers are in the Gearbox Interface Unit (GIU). It is also possible to put both the software and the drivers in a TCU.

## 8. Related Car Components

### 8.1 Centre Console LEDs

The configuration of which controle LEDs are to be used depends on customer.

### 8.2 Instrument Cluster Display

The same is valid for this part. The Instrument Cluster Display is also defined by the customer.

### 8.3 Selector Lever Mechanics

#### Park, Reverse, Neutral and Drive Switches

The configuration of the selector lever is customer specific. A shift lock (as in the picture below) must be integrated in the mechanism, to provide an idiot start protection.

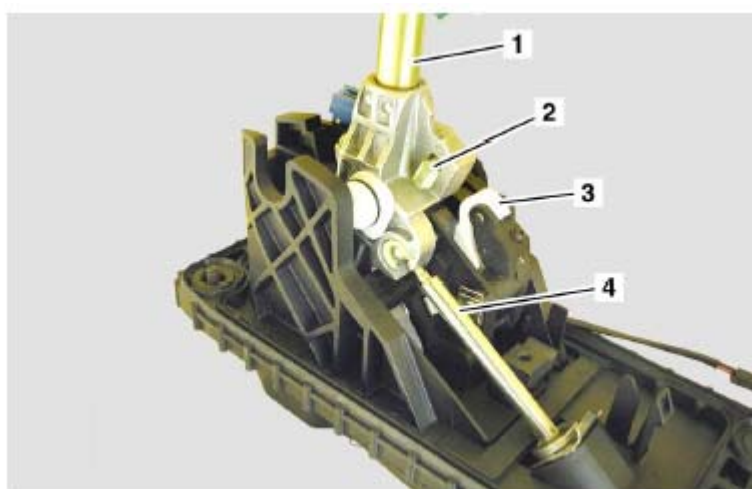

1. Gear selector lever
2. Gear selector lever detent
3. Shift lock
4. Gear change selector rod

Fig. 9: VT1F selector lever mechanism

## 8.4 Torsional damper

The engine is connected to the input shaft in the transmission, via a torsional damper, instead of the torque converter used by more conventional automatic transmissions.

This torsional damper is not a part of the transmission.

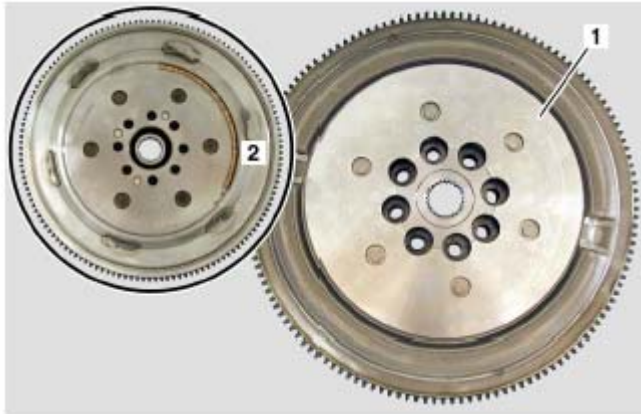

*Fig. 10: Torsional damper*

## 9. Towing of the Vehicle

The VT1F transmission must not be towed. This is because there is no oil pressure in the primary pulley unless the engine is running and belt slip would therefore occur. Recovery must be conducted with the front wheels lifted clear of the ground (suspended tow).

With a manual transmission it still is possible to start the car by pushing or towing. This is not possible with the CVT because there will be no oil pressure (as the engine and the pump are not running) meaning that both clutches are disengaged and that there is no connection between the engine and wheels.

## 10. Drain & Refill

A refill of the transmission oil is necessary every 45.000 km.

For this purpose, the gearbox is equipped with an oil drain plug and a top filler plug.

## II. Transmission Layout

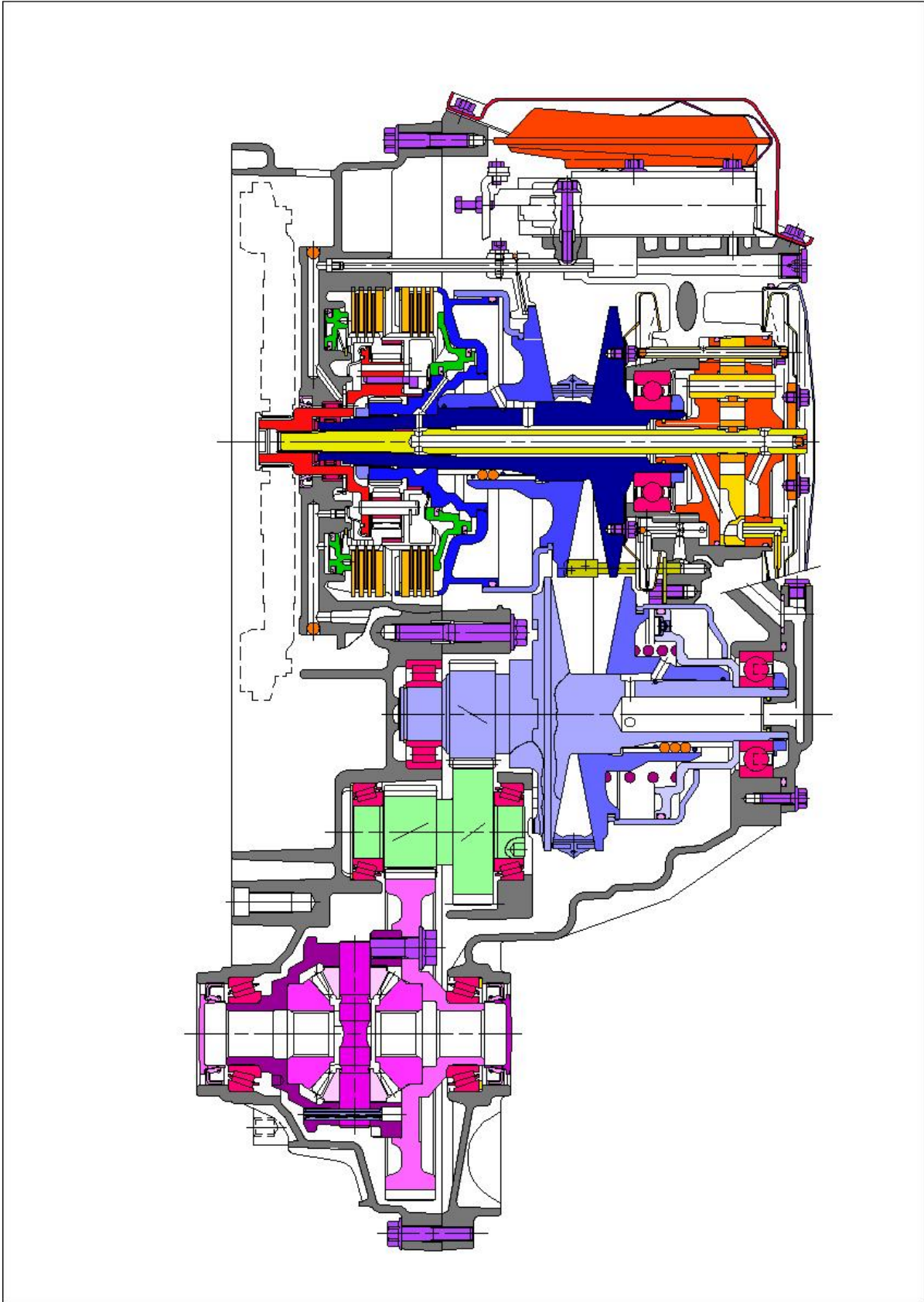

Fig. 11: VT1F transmission Layout

The VT1F consists of a number of elements that can be divided into three groups, depending upon their function.

### **Group One – Mechanical Torque Flow**

Elements providing the mechanical torque flow through the transmission.

### **Group Two – Control system**

These elements relate to the control system. This system enables the transmission to transmit power and to vary the ratio in a proper way, according to load conditions and driver demand.

### **Group Three – External Connections**

A number of elements have external connections with the transmission. Some of these elements are either inside the gearbox, or immediately connected to it. Others can be part of the system, but can be located elsewhere on the vehicle.

## **1. Group One - Mechanical Torque Flow**

### **1.1 Planetary Gear Set**

The planetary gear set enables the transmission to provide a drive torque in two directions, forward and reverse. Engine torque always enters the transmission through the input shaft of the planet carrier. This carrier can be directly connected to the sun-wheel by closing the forward multi-plate clutches. When it does, the epicyclic gear set rotates as one unit, and engine torque is transmitted directly to the primary pulley. The planet gears do not transmit any torque, therefore no mechanical loss will occur in the planetary gear set and the primary pulley will rotate in the same direction as the engine. This is the forward drive mode.

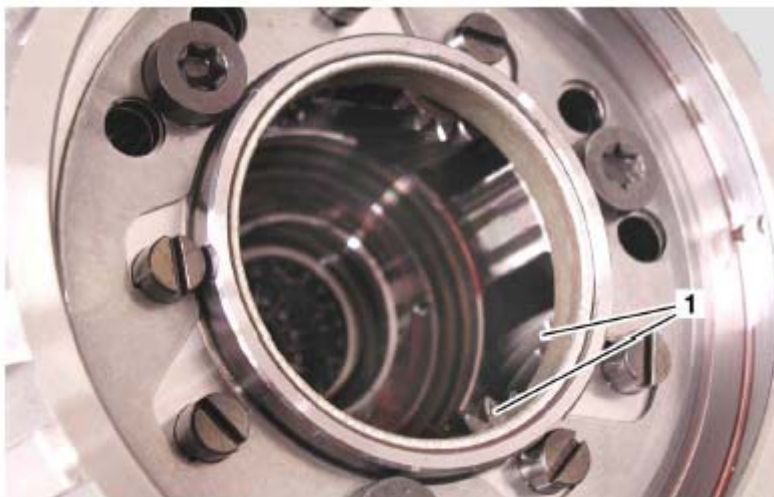

*Fig. 12: Planet gears*

In reverse mode, the annulus of the planetary gear set is held stationary by closing the reverse multi-plate clutches. Three pairs of planet gears are driven by the planet carrier, forcing the sun-wheel to rotate in the opposite direction.

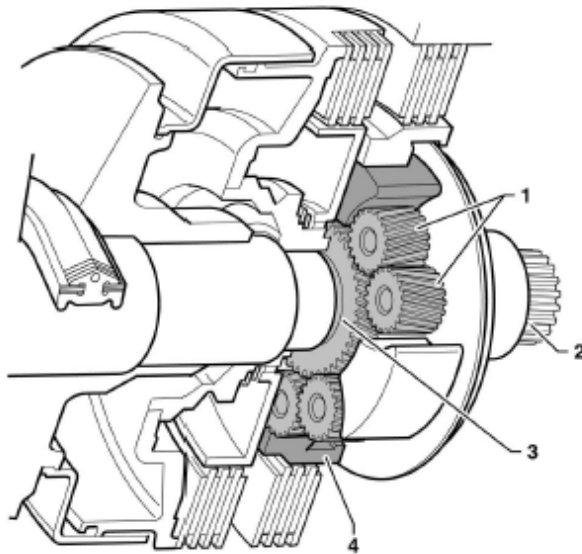

1. Planet gears
2. Input shaft
3. Sun gear
4. Annular gear

*Fig. 13: Planet gears*

There is a small multiplication of torque being transmitted since the ratio of the epicyclic gear set is 1:1.1, in order to compensate for frictional losses within the planetary gear set itself.

### **1.2 Multiplate clutches.**

There are two Multiplate wet clutch packs; one forward and one reverse. Each pack has three friction plates providing six friction surfaces. The hydraulic pressure controls the clutches to allow the vehicle to move away smoothly by every throttle opening. By controlling the belt slip it also allows the vehicle to be held stationary after the drive gear is engaged. Oil from the oil cooler is directed to the clutch plates to prevent overheating of the friction surfaces.

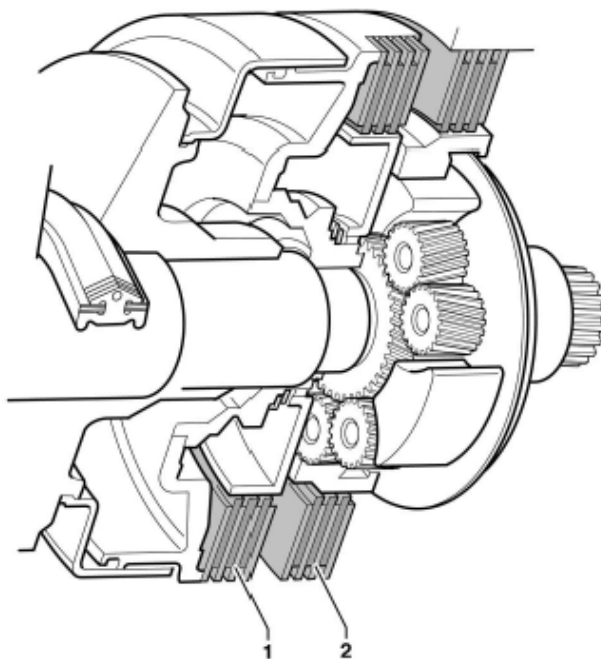

1. Forward clutch pack
2. Reverse clutch pack

*Fig. 14: Planetary gear set showing clutch plates*

### 1.3 Pulley and Steel Belt

The main design feature of the CVT is a pair of steel "V" shaped pulleys connected by a steel drive belt. The distance between centres of the primary and secondary pulley is 155 mm. Each pulley consists of one fixed half and one axially slideable half, both having 11 degree sloping sides. The proven 24 mm wide "Van Doorne" push type drive belt is used to transfer torque between the pulleys (applications for higher torque values can make use of a 30 mm drive belt). The belt is lubricated and cooled by an oil jet from a nozzle. Both moving halves are situated diagonally opposite to each other in order to reduce misalignment of the drive belt during shifting. Each moving half is connected to a hydraulic cylinder/piston. Hydraulic pressure is controlled by the control system, described in the section titled 'Hydraulic system'. Ball splines prevent the moving halves from rotating relatively to their fixed partners.

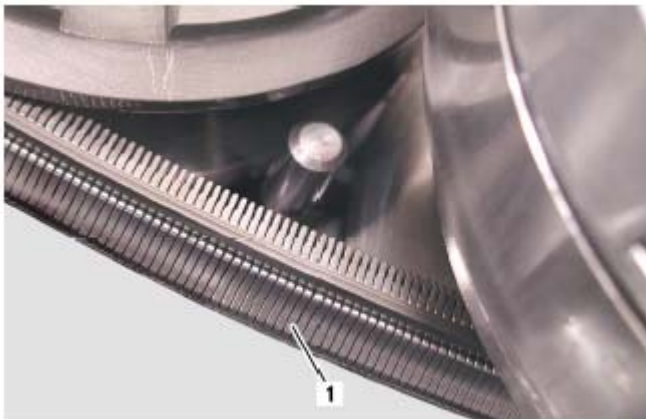
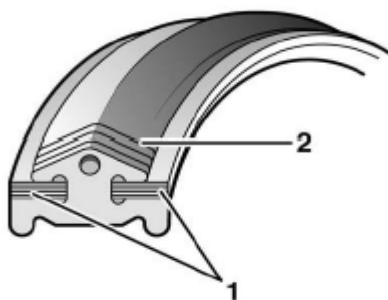

Fig. 15: Steel Drive belt

Torque transmitted by the planetary gear set acts directly onto the primary pulley, as the sun-wheel is splined to it. The steel drive belt transmits the power from the primary pulley to the secondary pulley and the power from the secondary pulley is then transmitted to the pinion shaft.

Torque and speed of the secondary pulley are determined by the position of the drive belt. The sizes of the two pulleys are designed to provide a range of ratios from 2.416:1 to 0.443:1 resulting in a ratio spread of 5.45. The high overdrive ratio is particularly advantageous in respect to fuel consumption.

The steel drive belt has approximately 450 segments and is held together by 24 steel bands, 12 on each side. All the segments are of the same thickness.



1. Steel bands
2. Steel segments

Fig. 16: Drive belt

### 1.4 Pinion Shaft

The pinion shaft creates a two-set helical gear reduction between the secondary pulley and the differential. In this way, the rotational direction of the drive shafts will be correct. The reduction between the secondary pulley and the drive shafts can be made large enough to give good vehicle performance. The pinion shaft is supported by two conical bearings, one in the clutch housing and one in a separate bearing support.



1. Primary shaft drive gear
2. Differential crown wheel
3. Pinion drive gear
4. Transfer gear pinion shaft
5. Secondary shaft drive gear

*Fig. 17: Crown wheel & pinion*

### 1.5 Differential

Drive torque on the crown wheel is transmitted to the vehicle wheels via a bevel gear differential, just as in a manual transmission. The crown wheel is bolted to the differential case with 8 bolts. The drive shafts are fitted to the differential with conventional CV joints and seals. Conical bearings are used to support the differential.

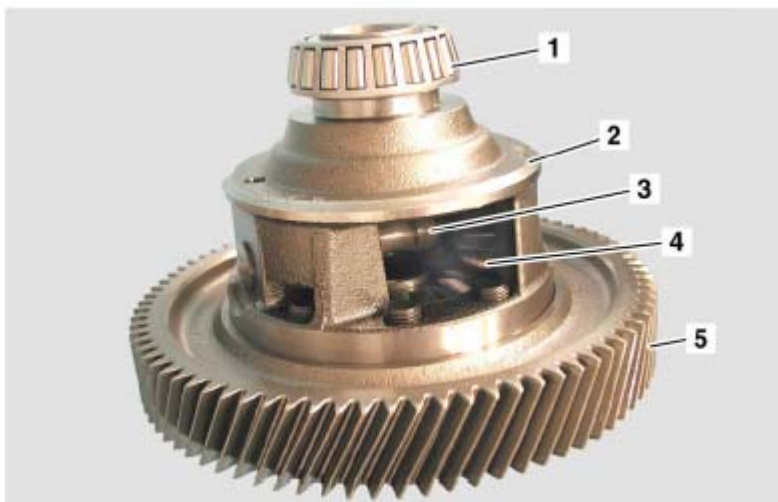

1. Differential bearing
2. Differential casing
3. Differential cross shaft
4. Differential planet gears
5. Differential crown wheel

*Fig. 18: Differential assembly*



## 1.6 Mechanical Operation

### 1.6.1 Selector lever in the park or neutral position

In this condition motion is not transferred to the wheels as both clutches for reverse (2) and forward gears (4) are disengaged.

- The transmission input shaft (1) turns at the same speed as the engine.
- The reverse gear clutch (2) is disengaged.
- The forward gear clutch (4) is disengaged.
- The planetary gears (3) idle around the sun gear.
- As the sun gear does not move, neither does the primary pulley (5), the secondary pulley (7) and, subsequently, the vehicle.

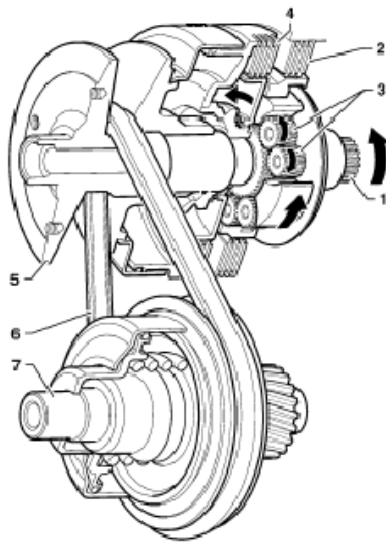

1. Input shaft
2. Reverse gear clutches
3. Planetary gears
4. Forward gear clutches
5. Primary pulley
6. Steel drive belt
7. Secondary pulley

*Fig. 19: Pulleys & gear train*

### 1.6.2 Selector lever in the drive position

Under this condition, the forward motion is transferred to the wheels as the forward clutch (4) is engaged.

- The transmission input shaft (1) turns at the same speed as the engine.
- The reverse clutch (2) is disengaged.
- The forward clutch (4) is engaged.
- The planetary gears (3), the sun gear and the annular ring gear of the epicyclic train rotate together.
- The primary pulley (5) turns at the same speed as the engine in the forward gear direction.
- The secondary pulley (7) turns in the forward gear direction at a speed that depends upon the belt ratio for that operating condition.

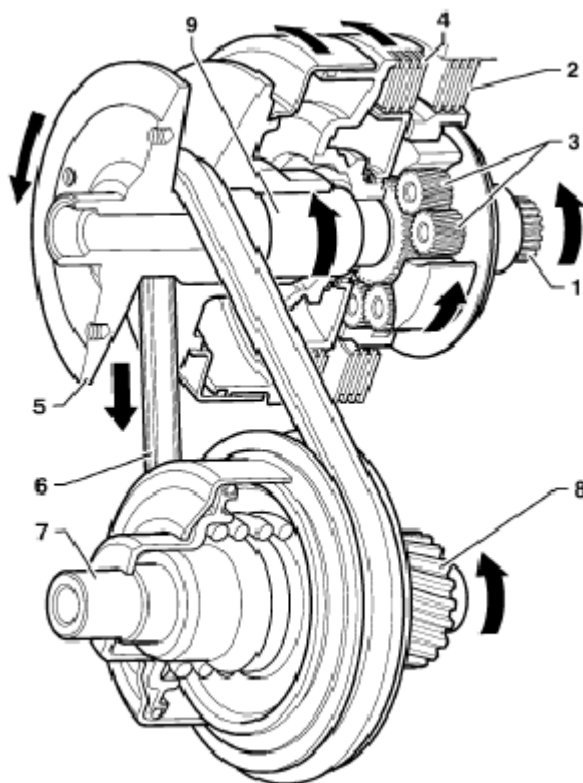

1. Input shaft
2. Reverse gear clutches
3. Planetary gears
4. Forward gear clutches
5. Primary pulley
6. Steel drive belt
7. Secondary pulley
8. Secondary pulley
9. Input shaft

Fig. 20: Pulleys & gear train

### 1.6.3 Selector lever in the reverse position

Under this condition, the reverse clutch (2) is engaged and makes the annular ring gear (9) lock to the transmission case. The planetary gears (3) force the sun gear (10), the primary pulley (5) and the secondary pulley (7) to turn in the opposite direction to the transmission input shaft (1). Therefore reverse gear is now selected.

- The transmission input shaft (1) turns at the same speed as the engine.
- The reverse clutch (2) is engaged.
- The forward clutch (4) is disengaged.
- The annular gear (9) is linked with the transmission case by means of the reverse clutch (2).
- The planetary gears (3), which are driven directly by the transmission input shaft (1), turn around the annular gear (9). Therefore they force the sun gear (10), the pulley (5) and the secondary pulley (7) to turn in the reverse gear direction.

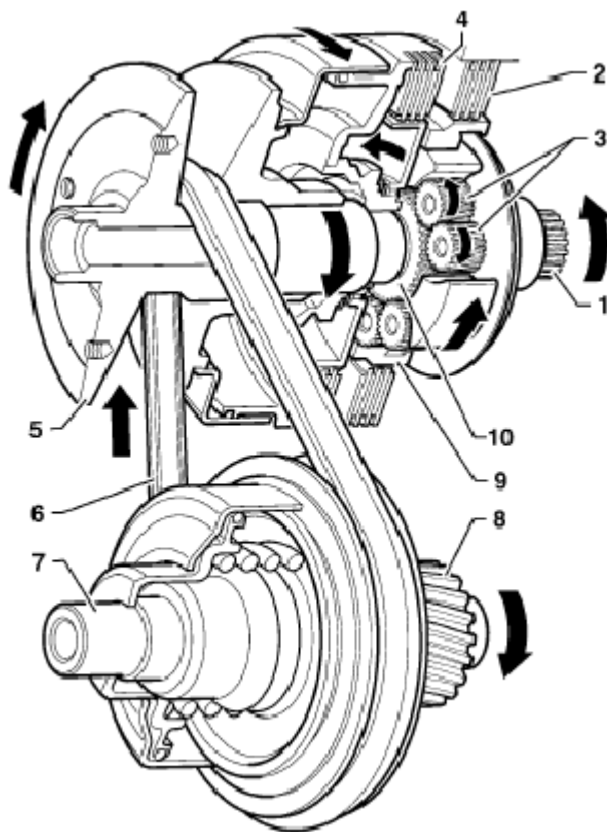

1. Input shaft
2. Reverse gear clutches
3. Planetary gears
4. Forward gear clutches
5. Primary Pulley
6. Steel drive belt
7. Secondary pulley
8. Secondary pulley
9. Annular gear
10. Sun gear

Fig. 21: Pulleys & gear train

## 2. Group Two - Control System

The functions of the control system are:

1. To match the clamping force on the steel drive belt tension with engine torque, preventing belt slip.
2. To control the operation of the forward and reverse clutches during driving and take off.
3. To provide the optimum transmission ratio for all driving conditions.
4. Provide the necessary lubrication and cooling oil in the gearbox.
5. Provide the required oil supply for the pitot systems.

### 2.1 Oil Pump

The pump within the transmission is an external gear pump. The engine drives it via a shaft through the hollow primary pulley shaft. The pump shaft is splined to the planet carrier, which always run at engine speed. The discharged volume is about 10 cm<sup>3</sup> per revolution. System pressure can reach 40 to 50 bar depending on input torque.



1. Oil pump drive shaft
2. Oil pump assembly

Fig. 22: Oil pump complete

The oil pressure is used both for controlling the transmission hydraulically, and for lubrication purposes.

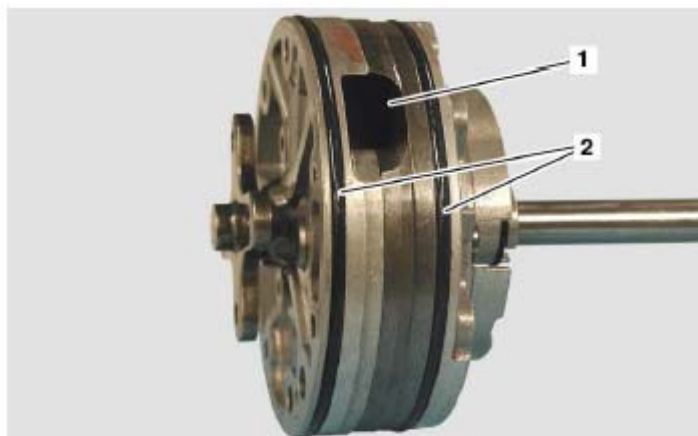

1. Oil pump inlet
2. Oil pump oil seals

Fig. 23: Oil pump inlet

## 2.2 Valves

The CVT is controlled by a number of valves that respond to mechanical, electrical and hydraulic inputs. Basically, the control system is designed to control the ratio, the clamping force and the clutches in the following four ways:

1. Flow to and from the primary pulley is controlled to command the correct transmission ratio for all driving conditions. In this range a primary valve and a linear actuator is used.
2. Pressure is supplied to the secondary pulley to ensure that there is always adequate clamping force onto the belt for all load conditions. A solenoid valve influences the secondary pressure control valve, optimising the pressure and hence the clamping force. Optimisation of this pressure improves fuel consumption. The working valves in this area are the secondary valve, the exhaust secondary valve, and a PWM solenoid secondary valve.
3. Selection of the correct clutch (forward or reverse). Engagement of forward or reverse gear via the selector mechanism operates the manual valve directing oil to the appropriate clutch. For this functions there is a manual valve and a reverse inhibitor valve.
4. Control of the operation needed for take off: A solenoid valve acting on the clutch valve controls the clutch application pressure to ensure smooth clutch engagement and drive away at all throttle openings. Here a clutch valve, an exhaust valve clutch pressure, a constant pressure valve, the supply valve and the PWM solenoid clutch valve are used.

There also is a cooler flow valve that controls the oil flow through the cooler.

## 2.3 Pitot system

The engine speed and the drive mode are used for controlling the clutch engagement. The speed dependent signals are provided by two 'pitot' systems. Each consists of a pitot chamber and a pitot pipe. The pipe is stationary, while the chamber, which is filled with oil, is rotating at the speed to be measured.

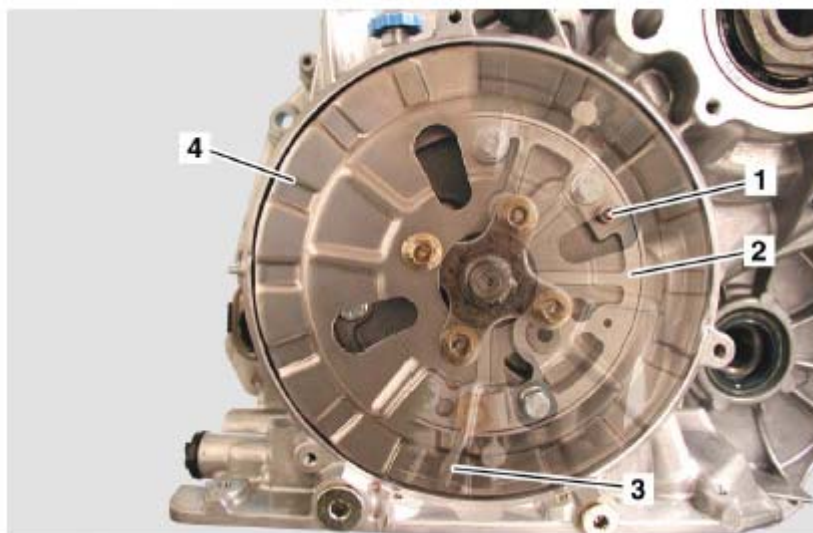

1. Pitot tube
2. Oil pump
3. Pitot tube
4. Pitot chamber

Fig. 28: Pitot tube ghosted inside cover

A hydraulic pressure, proportional to speed, is detected at one end of the pipe, which is dipped in the rotating oil ring inside the pitot chamber. These pressures act on the primary, secondary and clutch valves inside the control unit, influencing transmission operation.

## 2.4 Sensing shoe

The sensing shoe is a mechanism that measures the position of the pulleys. The sensing shoe acts via a rocker onto the secondary valve spring within the hydraulic control unit, controlling the clamping force. The clamping force can be decreased when the transmission up-shifts, as the drive belt will run on a bigger radius around the primary pulley. With the drive belt running in an overdrive situation, a lower secondary pressure will still create enough clamping force to transmit the torque.

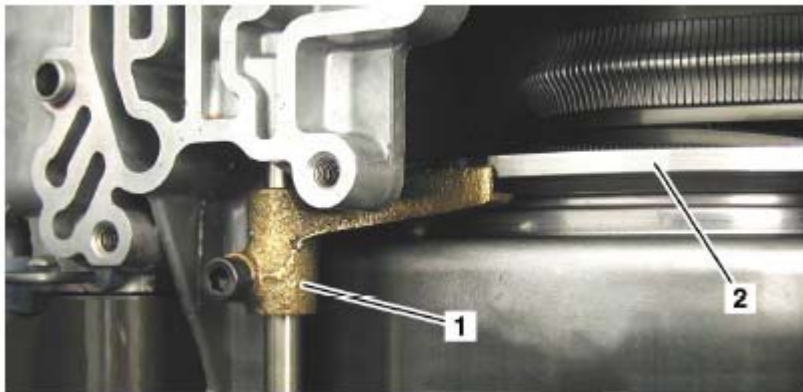

1. Sensing shoe
2. Pulley

Fig. 29: Sensing shoe in box

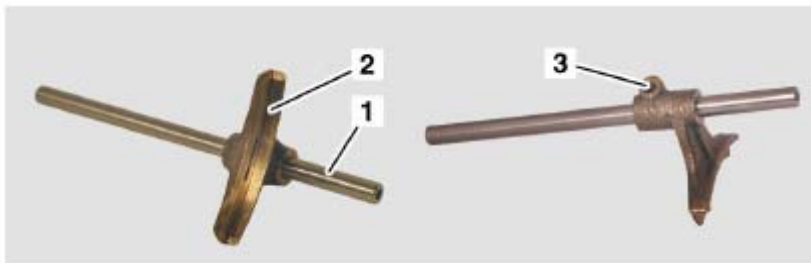

1. Sensing shoe shaft
2. Sensing shoe
3. Sensing shoe locking bolt position

Fig. 30: Photo sensing shoe

## 2.5 Oil Temperature Sensor

The oil temperature sensor is a two wire sensor and is located in the valve block area.

The sensor continuously monitors the temperature of the oil. Should the oil temperature rise above preset parameters, the ECU will reduce the amount of slip within the clutch to reduce the oil temperature.

### 3. Group Three - External Connections

Each element of group three will now be described.

#### 3.1 Park/Neutral Switch

The selector cam activates the park/neutral switch, which prevents the car from starting in reverse, drive or sport, and switches on the reverse lights when in reverse. The switch also sends its position to the CVT Software in the ECU that uses this switch in conjunction with the gear selector switch to establish the correct driving mode.



*Fig. 31: Park/Neutral switch*



1. Park/Neutral switch plunger
2. Selector cam

*Fig. 32: Switch & selector mechanism*

When the selector lever is in the park or neutral position and the ignition is switched on, the CVT software in the ECU will energise a shift lock solenoid on the selector lever in the car. This locks the lever in the park or neutral position. The selector lever cannot be moved from the park or neutral position until the footbrake is applied.

### 3.2 Oil Cooler Locations

There are two oil cooler pipe connections on the front of the transmission casing. An oil cooler is fitted alongside the radiator to maintain the transmission oil temperature between 80°C and 120°C.

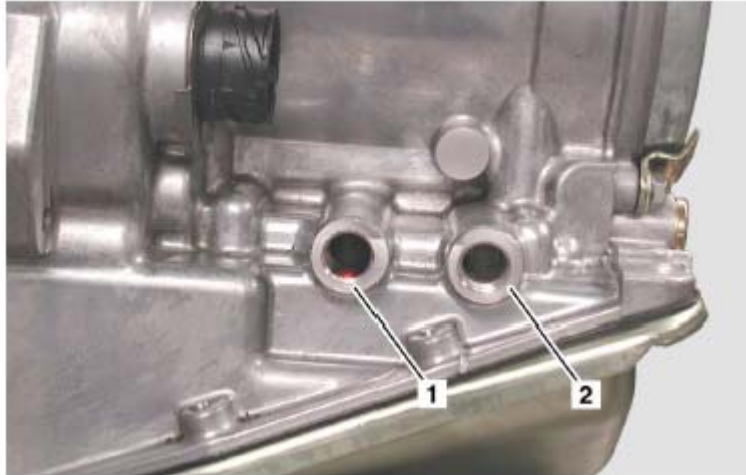

1. Oil cooler pipe inlet
2. Oil cooler pipe outlet

*Fig. 33: Oil cooler pipe position*



### 3.3 Transmission Secondary Speed Sensor

The VT1F transmission has a dedicated secondary speed sensor located in the differential housing. The sensor is located at the crown wheel. This sensor is a Hall effect sensor and produces a pulse train of 81 pulses per rotation. The sensor allows for more precise calculation of transmission output speed that is used in the control strategy systems.



Fig. 34: Secondary speed sensor in gearbox



- 1. Speed sensor
- 2. Speed sensor oil seal

Fig. 35: Secondary speed sensor

### 3.4 Selector Shaft

Selection of the required driving mode, through the selector lever inside the vehicle, activates a selector shaft within the transmission. A push/pull type cable connects the lever in the car and the shaft on the gearbox.



1. Retaining clip
2. Protection cover
3. Gear change rod
4. Gear change lever

*Fig. 36: Gear selection cable to gearbox rod*



1. Selector shaft

*Fig. 37: Gear selector rod in box*

### 3.5 Connector

The connector consists of 16 pins and is located in the transmission casing. The harness connection is via a circular connector.



*Fig. 38: Harness block on gearbox*

### III. Strategies

#### 1. Behaviour in Specific Situations

The behaviour of a vehicle, fitted with CVT, will now be discussed in the following specific situations:

##### 1.1 Idle While Drive is Selected

When the engine is started and drive selected without depressing the throttle pedal primary pitot pressure will be very low. There is no primary pressure and the belt is positioned on its lowest primary radius. The clutch valve determines the creep behaviour of the car with the engine running at idle. The cooler valve sends the coldest oil to the drive clutch.

##### 1.2 Take Off/Pulling Away

The position of the throttle pedal determines at which speed the transmission will up-shift. This is also dependent on which drive mode is selected (Drive, Sport or Manual). Pushing the throttle pedal down will result in the following actions:

- As the engine speed increases so does the engine pitot pressure and the clutch pressure.
- If the clutch pressure becomes too high it will bleed into the exhaust valve clutch pressure. The bleeding of the clutch pressure is set so that the full engine torque can be transmitted at any time. Via the forward clutch, the primary pulley starts accelerating and the primary pitot pressure rises. It is this pressure that prevents reverse gear from being accidentally selected. At a specific speed the primary pressure rises and the primary pulley halves are pushed towards each other increasing the primary radius of the belt. As the belt is of a constant length the secondary pulley halves must widen accordingly.
- The transmission will up-shift at a constant engine speed until overdrive is reached. This strategy is only used to show the possibilities of a CVT. Other strategies with an engine speed that rises with the vehicle speed are also possible. Under constant conditions the speed of the vehicle will stabilise. If the load should increase, for example driving uphill, and the driver does not change the position of the throttle pedal, then the transmission automatically downshifts. The gradient makes the secondary speed drop. The primary speed wants to stay constant and the primary valve regulates the primary pressure in such a way that the engine speed does not change. Thus the primary pulley halves will widen and the primary radius of the belt will decrease. The secondary belt radius will increase because of the fixed belt length. The transmission has downshifted, and the engine speed stays the same but vehicle speed has dropped.

##### 1.3 Light Throttle Acceleration in Drive or Sport

The driver is at a fixed point in overdrive. Assuming the primary belt radius would be at a maximum, the secondary at a minimum. Light acceleration, by using the throttle pedal, will activate the ratio control motor acting upon the primary valve causing the primary pressure to drop. The transmission will downshift slightly, which will result in higher pitot pressure and balance within the primary valve restored. The transmission up-shifts at the new constant engine rpm.

#### **1.4 Kick-Down in Drive or Sport**

Fully depressing the throttle pedal will move the primary valve and the primary pressure will rapidly drop. The transmission shifts down as far as possible. The sensor shoe on the primary pulley creates a high spring force onto the secondary valve; therefore, the secondary pressure is kept at a sufficient high level to avoid belt slip. The balance in the primary valve can only be restored with a higher engine speed.

#### **1.5 Emergency Stop**

During design care has to be taken so that the vehicle, after an emergency stop, can take off again immediately. During an emergency stop situation the transmission has to downshift very quickly. The chamber on the secondary pulley must be filled very quickly to push the secondary pulley halves towards each other and to clamp the belt. The most critical situation is an emergency stop from a minimum engine speed. The required pump flow increases with the amount of braking.

The speed of the engine can only be held constant when the transmission has the time to downshift. This can cause some problems when braking on a slippery surface, for example, on ice, as the wheels will lock very fast. The clamping force and the locked clutches make the engine speed decrease very fast, to a speed at which the clutche disengages, bringing the pulleys to a standstill. In the primary valve the primary pressure is bleeding as there is no pitot pressure. Due to secondary pressure, the transmission down-shifts, although the shift time will be greater as the pulleys are standing still. This enables the transmission to be in a low ratio when the vehicle comes to a halt.

#### **1.6 Reverse Running**

With the manual valve in reverse, the clutch pressure will be sent to the reverse clutch via the reverse inhibitor valve. Once the vehicle is running in reverse, the clutch will stay under pressure because the primary pitot tube opening is in opposite direction to the oil flow within the pitot chamber, and therefore can sense no pressure. This keeps the reverse inhibitor valve in balance in the open position. Consequently the primary pressure will be bleeding and the transmission will stay in a low ratio.

#### **1.7 Fault Mode**

If the software detects an error within the system, a default strategy will be engaged. These conditions are communicated to the driver via the fault indication in the instrument cluster.

Depending on the severity of the fault, the driver will experience different default driving modes.

If the system is still able to control the transmission ratio, the standard limp-home is used to default the gearbox so that the shift up speed is fixed. This will protect the transmission under all driving conditions. Under most driving conditions, the astute driver will notice that the engine speed is hanging around 3000 rpm at most road speeds.

The most serious fault will cause the transmission to be stuck in a single gear ratio. If stuck in the lowest gear, the driver will see the engine speed quickly increase to 6000 rpm and stay there. The maximum possible vehicle speed is approximately 50 km/h. If stuck in the highest gear, the driver will experience very sluggish acceleration and engine speeds hanging around 2000 to 2250 rpm at vehicle speeds of up to 80 km/h.

The software can instruct the instrument cluster to display an error code, or the Engine MIL depending on legislative requirements.

There are certain faults that the software will not default the transmission into its limp home position.

These are:

1. Gear lever + switch failure.
2. Gear lever - failure.
3. Shift interlock system fault.
4. Centre Console LED fault.

Limp home position is not necessary for these failures because the control of the gearbox is not compromised; it is only necessary to warn the driver.

The ECU / TCU will not operate the sequential gear changes in manual mode if these switches are faulty.

## 2. CVT Software

The CVT software is incorporated into the CVT software either in the ECU or the TCU. The software does not control the transmission ratio directly but does provide all of the intelligence relating to the required position of the ratio control motor. It also provides the intelligence for how fast it should be operated.

The ECU or the TCU controls the transmission in one of the following modes. Again, extra modes (economy, comfort, winter, ...) could be integrated too:

1. **Drive mode** (normal CVT driving).
2. **Sport CVT mode** or **Low CVT mode**.
3. **Manual mode**.
4. **Fault mode**.
5. **Reverse mode**

In the CVT modes, the control system operates by deriving a target engine speed based on current vehicle speed and driver demand. In manual mode, the system derives a target engine speed based on the vehicle speed and the current gear ratio. Having obtained an engine speed target, the system calculates the appropriate ratio control motor position and instructs the GIU or the drivers in the TCU to deliver this position.

The ECU / TCU also needs to control the speed of the ratio control motor in order to protect the transmission from damage due to drive belt slippage.

The software in the ECU / TCU also knows the maximum torque that the belt can transfer across all possible ratio ranges. It is extremely important that the belt does not slip on the pulleys, as this would cause excessive wear.

### **3. Transmission Reset and Reference**

The CVT software in the ECU / TCU controls the position of the ratio motor. It does this by sending the exact position (in steps) it wishes the GIU / driver to set the stepper motor. The software then monitors the engine speed to ensure that the engine speed has altered in accordance with the expectations. If the engine speed does not follow the expectations it is assumed that the GIU / driver has lost its position reference of the stepper motor. When this loss of position happens the software orders a reset. The GIU / driver then resets it's internal position counter to that of the ECU / TCU. The ECU /TCU will also stop any learning for that ignition cycle.

The ECU completes a reference every time the ignition is switched 'off' or 'on'. These two references are different because of the need to set the transmission in the appropriate position.

#### **IV. Adaptation Procedures**

Due to manufacturing tolerances in the transmission, and since the VT1F system is subject to many strict legislative requirements, it is essential to put the control system through a learning procedure, before the transmission can be controlled effectively.

On the completion of the adaptation, the lifetime adaptation strategy will commence; fine tuning the response of the control system for the transmission attached to a particular vehicle. If either the ECU / TCU, GIU / driver or transmission is changed during the service life of the vehicle, the adaptation strategies must be reset, which in turn will reset the lifetime strategy so it starts learning from the new base point.