

Installation

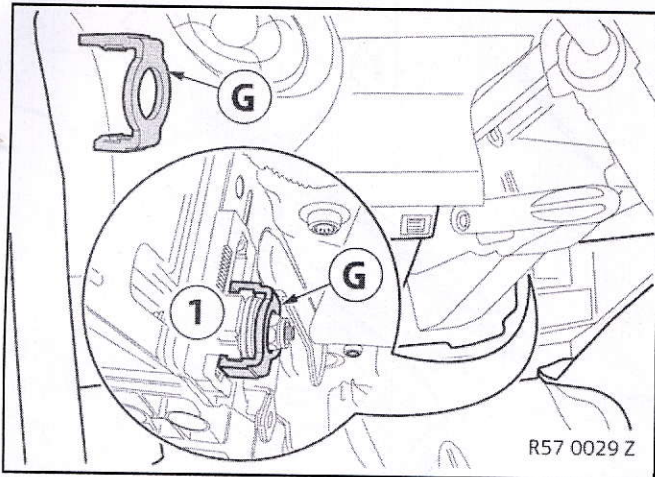

Adjust the steering column to the lower position.
Clip clamp **G** with the longer arm on top into steering column adjustment (1).

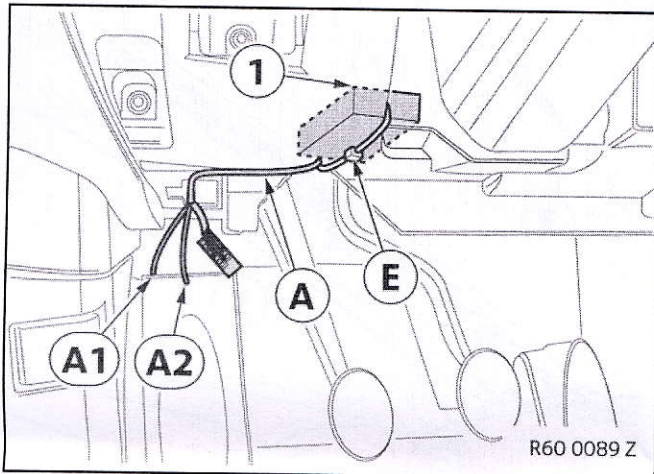

Route the wiring harness of navigation device **A** along the steering column of the existing standard wiring harness behind the dashboard.

Secure charging electronics box (1) of the wiring harness to navigation device mount **A** using cable tie **E** on the dashboard.

Route branches **A1** and **A2** to the OBD diagnostic socket.

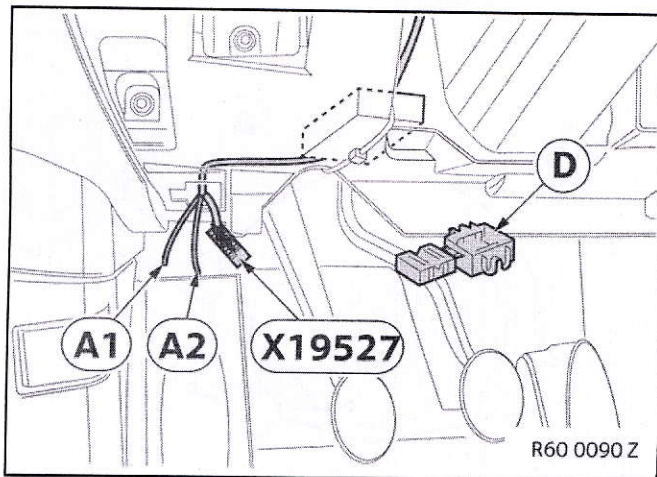

Connect branches **A1** and **A2** as follows to OBD diagnostic socket **X19527**:

- Branch **A1**, RT cable, with miniature connector **D** to the GN/BL cable from PIN 1 of OBD diagnostic socket **X19527**
- Branch **A2**, SW cable, with miniature connector **D** to the BR cable from PIN 5 of OBD diagnostic socket **X19527**

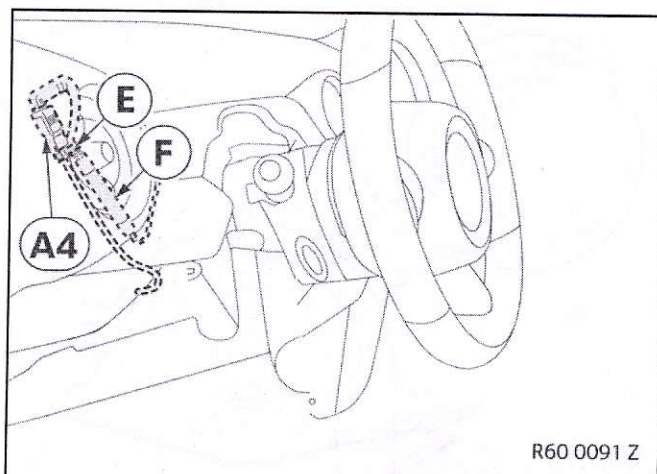

Only with the optional installation of the TMC aerial for 3.5" navigation device or where the navigation device is converted from 3.5" to 4.3"

Connect TMC aerial **F** to branch **A4** and secure with cable tie **E**. Route the aerial cable from TMC aerial **F** to the A-pillar.