

3. Retrofit cable set connection diagram

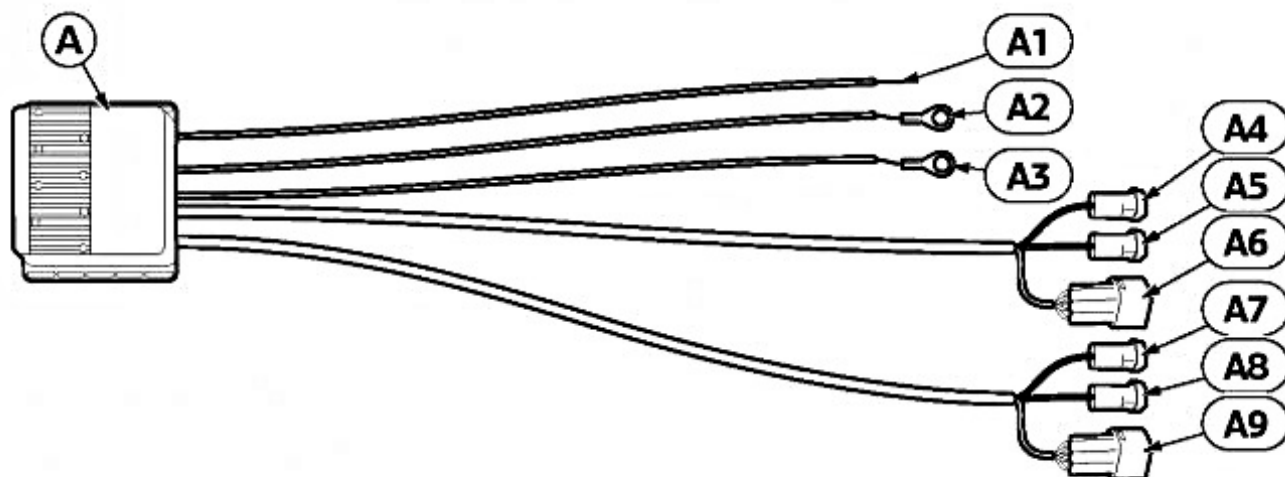

F57 0047 Z

| Item | Designation | Signal | Cable colour/ cross-section | Connection location in the car | Abbreviation/ slot |
|------|-----------------------------|-------------|--------------------------------|---|-----------------------|
| A | Control unit with cable set | --- | --- | --- | --- |
| A1 | Cable open | Terminal 15 | BL 0.5 mm ² | With crimp connector E to the GR cable of the footwell module A4011 | X14261 PIN 12 |
| A2 | Ring eyelet M6 | Terminal 30 | RT | To fuse box in engine compartment A400a | X10201 |
| A3 | Ring eyelet M6 | Terminal 31 | SW 0.5 mm ² | To ground support point X13004 | X13004 |
| A4 | SW 2-pin socket casing | --- | VI 0.5 mm ² | To the front, left plug of the vehicle | X129 |
| A5 | SW 2-pin socket casing | --- | WS 0.5 mm ² | To the front, left plug of the vehicle | X768 |
| A6 | WS 6-pin socket casing | --- | --- | To the front, left LED daytime running light B | --- |
| A7 | SW 2-pin socket casing | --- | GE 0.5 mm ² | To the front, right plug of the vehicle | X769 |
| A8 | SW 2-pin socket casing | --- | GN 0.5 mm ² | To the front, right plug of the vehicle | X136 |
| A9 | WS 6-pin socket casing | --- | --- | To the front, right LED daytime running light C | --- |

4. Preparatory work

| | ISTA No. |
|--|-------------------------|
| Conduct a brief test | --- |
| Disconnect the negative pole of the battery | 12 00 ... |
| The following components must be removed first of all | |
| Front ornamental grille | 51 13 000 |
| Front trim panel on wheel house, left and right | 51 13 102 |
| Bumper trim | 51 11 156 |
| Left headlight (adaptive cornering light) or left headlight (xenon) | 63 12 015/ 63 12 010 |
| Right and left fog lights (no longer required) | 63 17 075 |
| Left cowl panel cover | 51 13 123 |
| Left and right windscreen wipers | 61 61 081 |
| Front left door sill strip | 51 47 000 |
| Detach footwell module | 61 35 115 |

5. Installation and cabling diagram

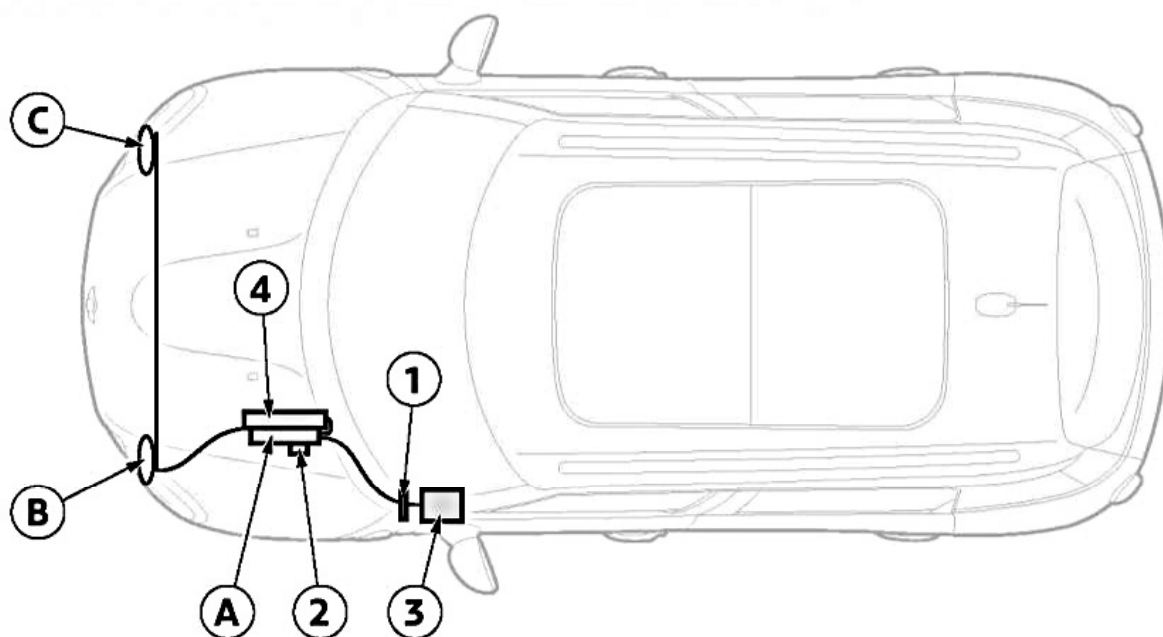

R57 0048 Z

- A** Control unit with cable set
- B** LED daytime running light, left
- C** LED daytime running light, right

- 1** Rubber grommet
- 2** Ground support point **X13004**
- 3** Footwell module **A4011**
- 4** Power distribution box in engine compartment **A400a**

6. Installing the retrofit cable set and LED daytime running lights

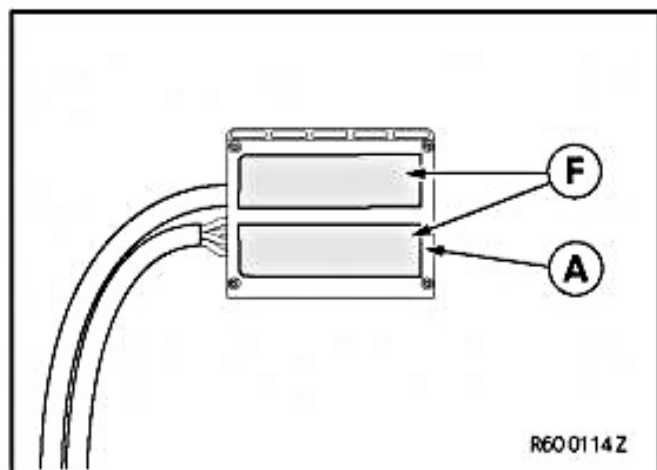

☐ Clean the surfaces to be bonded. ◀

Affix adhesive pads **F** to the back of control unit **A**.

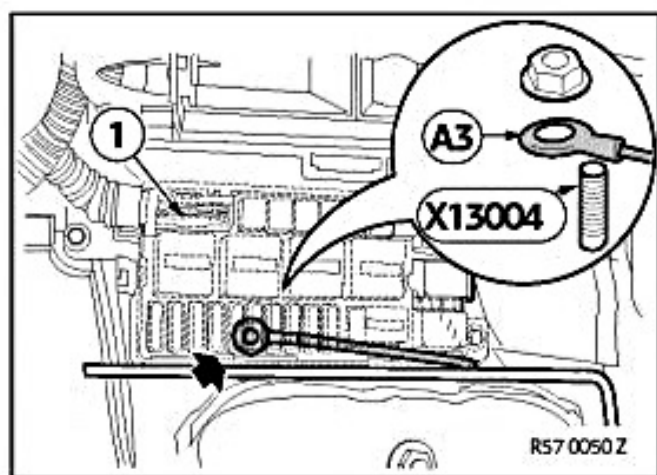

Detach power distribution box **A400a** in the engine compartment and fold to the side.

Secure branch **A3** to the ground support point **X13004** underneath.

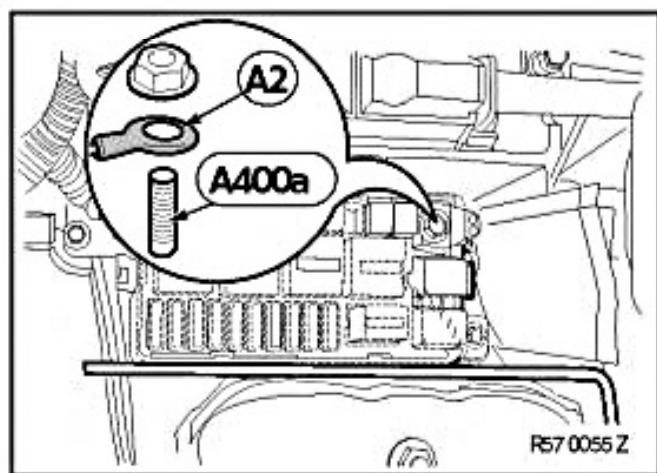

Secure power distribution box **A400a** in the engine compartment.

Secure branch **A2** to the power distribution box **A400a** in the engine compartment.

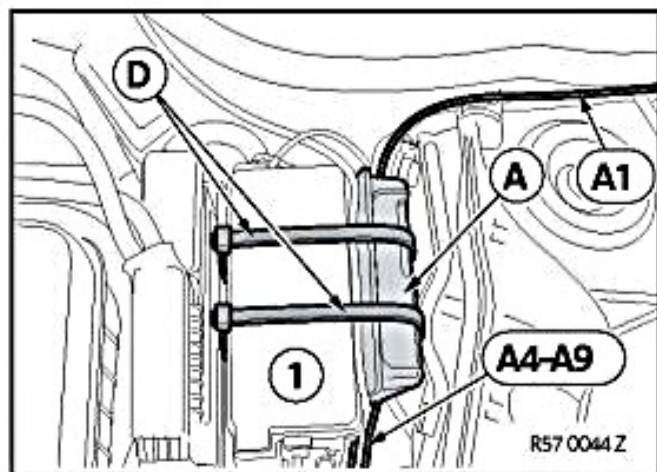

☐ Depending on the engine type, an alternative installation location may have to be defined. ◀

Affix control unit **A** to the power distribution box in the engine compartment (1) and secure with cable ties **D**.

Route branch **A1** to the bulkhead of the driver's side.

Route branches **A4-A9** to the LED daytime running lights.

6. Installing the retrofit cable set and LED daytime running lights

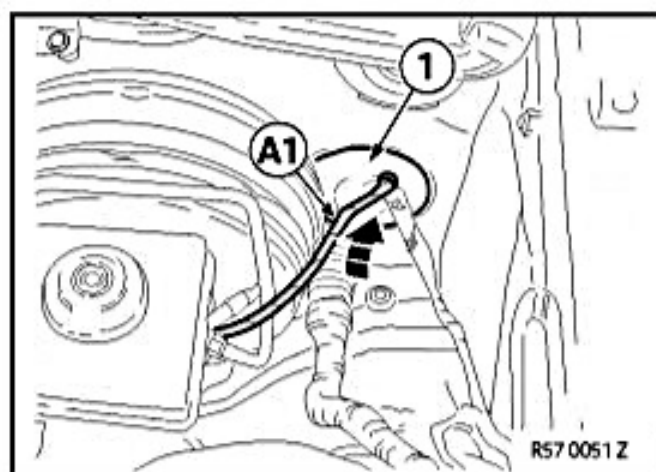

Route branch **A1** through rubber grommet (1) in the partition wall into the interior of the car.

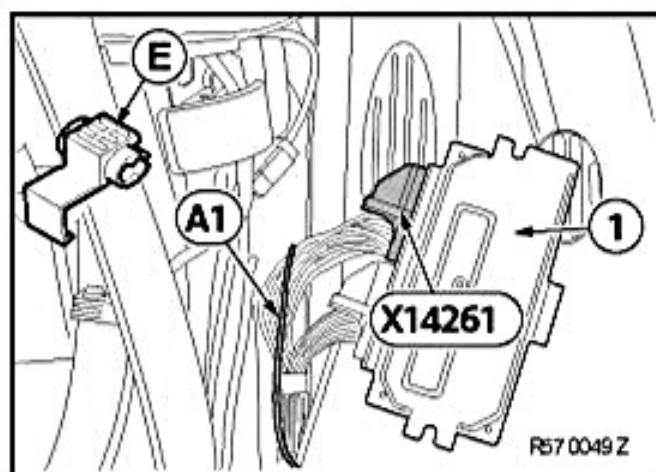

Connect branch **A1**, cable colour BL, with miniature connector **E** to the cable from Pin 12 of plug **X14261**, SW 51-pin socket housing, of the footwell module(1).

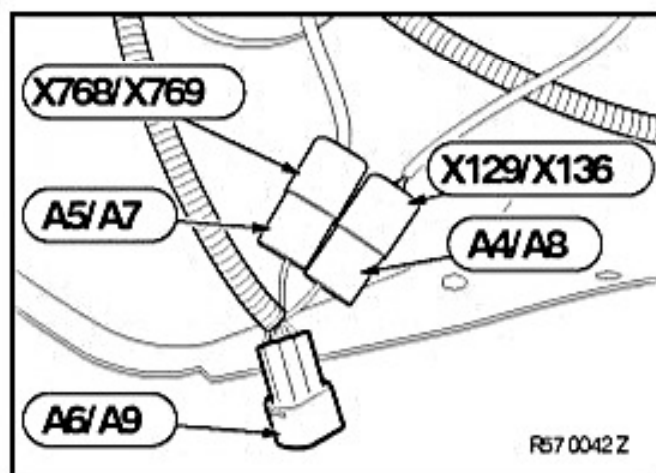

Connect branches **A4-A5** as follows to the left vehicle side:

- Branch **A4** to plug **X129**
- Branch **A5** to plug **X768**

Connect branches **A7-A8** as follows to the right vehicle side:

- Branch **A7** to plug **X769**
- Branch **A8** to plug **X136**

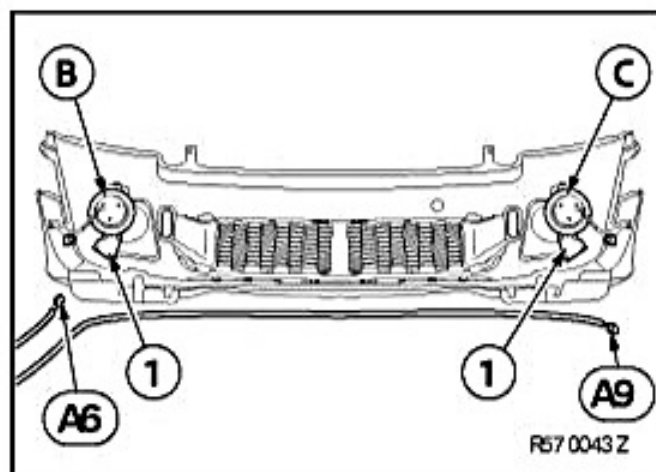

Remove original fog lights support (1), see ISTA 63 17 075.

Attach LED daytime running lights **B** and **C** using the available mounting material to support (1) and mount to bumper trim, see ISTA 63 17 075.

Plug branches **A6** and **A9** into LED daytime running lights **B** and **C**.

Attach bumper trim, see ISTA 51 11 156.