

# ORIGINAL MINI ACCESSORIES. INSTALLATION INSTRUCTIONS.



## Additional Headlight Retrofit MINI (F56)

Installation instructions only valid for US cars

### Retrofit kit number

63 12 0 417 885	Additional headlight retrofit kit, black
63 21 0 420 292	Additional headlight retrofit kit, chrome
63 12 2 355 769	Additional headlight bracket, US
63 12 2 284 922	Interface add-on kit (only for cars with SA 5A2 or SA 5A4)
51 45 2 355 772	Additional headlight button

### Installation time

The installation time is **approx. 2.0 hours**. This may vary depending on the condition of the car and the equipment in it.

### Important information

These installation instructions are primarily designed for use within the MINI dealership organisation and by authorised MINI service companies.

In any event the target group for these installation instructions is specialist personnel trained on MINI cars with the appropriate specialist knowledge.

All work must be completed using the latest MINI repair manuals, wiring diagrams, servicing manuals and work instructions, in a rational order, using the prescribed tools (special tools) and observing current health and safety regulations.

**If you experience installation or function problems, restrict troubleshooting to approx. 0.5 hours for mechanical work and 1.0 hour for electrical work.**



To avoid unnecessary extra work and/or costs, send an inquiry straight away to the technical parts support team via the Aftersales Assistance Portal (ASAP).

Quote the following information:

- Vehicle identification number,
- Retrofit kit part number,
- A detailed description of the problem,
- Any work already carried out.

Do not archive the hard copy of these installation instructions since daily updates are provided via ASAP!

### Pictograms

-  Denotes instructions that draw your attention to dangers.
-  Denotes instructions that draw your attention to special features.
-  Denotes the end of the instruction or other text.

### **Installation information**

Ensure that the cables and/or lines are not kinked or damaged as you install them in the car. Costs arising from this will not be reimbursed by BMW AG.

Additional cables/wires that you install must be secured with cable ties. If the specified PIN chambers are occupied, bridges, double crimps or twin-lead terminals must be used.

After installation, the additional headlights must be adjusted.

 Note the ESD guidelines. ◀

### **Customer information**

Print out the **Customer information** section at the end of these installation instructions and give it to the customer.

### **List of special equipment**

The following special equipment must be taken into consideration when installing:

**SA 5A2** LED headlight

**SA 5A4** LED headlight with cornering light

### **Special tools required**

Details of the special tool required can be found in the relevant ISTA repair manual.

Section	Page
1. Parts list for retrofit kit .....	4
2. Preparatory work .....	5
3. Retrofit wiring harness connection diagram .....	6
4. Installation and cabling diagram .....	7
5. Routing and connecting the retrofit wiring harness .....	8
6. Working with the bumper trim and installing the additional headlight .....	13
7. Concluding work and coding .....	15
8. Wiring diagram .....	16
9. Customer information .....	18

## 1. Parts list for retrofit kit

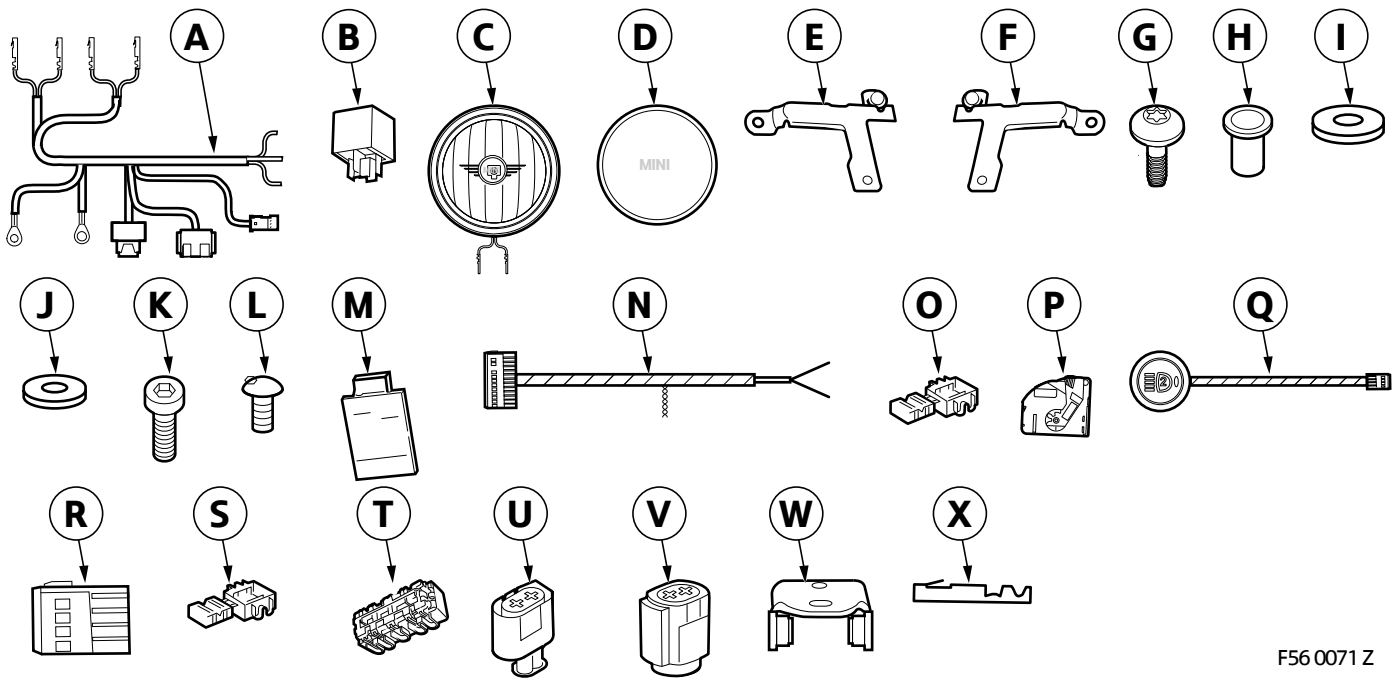

F56 0071 Z

### Legend

- A** Retrofit wiring harness (part of the additional headlight retrofit kit)
- B** Control module (part of the additional headlight retrofit kit)
- C** Additional headlight (2 x, part of the additional headlight retrofit kit)
- D** Cover cap (2 x, part of the additional headlight retrofit kit)
- E** Left additional headlight bracket (part of the additional headlight bracket retrofit kit)
- F** Right additional headlight bracket (part of the additional headlight bracket retrofit kit)
- G** Pan head screw (2 x, part of the additional headlight bracket retrofit kit)
- H** Rivet nut (2 x, part of the additional headlight bracket retrofit kit)
- I** Spring washer D = 6.4 mm (4 x, part of the additional headlight bracket retrofit kit)
- J** Spring washer D = 5.3 mm (2 x, part of the additional headlight bracket retrofit kit)
- K** Screw M6x16 (4 x, part of the additional headlight bracket retrofit kit)
- L** Screw M5x12 (4 x, part of the additional headlight bracket retrofit kit)
- M** Interface (only for cars with SA 5A2 or SA 5A4, part of the interface add-on kit)
- N** Wiring harness interface (only for cars with SA 5A2 or SA 5A4, part of the interface add-on kit)
- O** Miniature connector (4 x, only for cars with SA 5A2 or SA 5A4, part of the interface add-on kit)
- P** Cover cap (only for cars with SA 5A2 or SA 5A4, part of the interface add-on kit)
- Q** Button (part of the additional headlight button retrofit kit)
- R** BL 6-pin socket casing (part of the additional headlight button retrofit kit)
- S** 2-way miniature connector (2 x, part of the additional headlight retrofit kit)
- T** 5-way miniature connector (part of the additional headlight retrofit kit, not required)
- U** SW 2-pin socket casing (2 x, part of the additional headlight retrofit kit)
- V** SW 2-pin pin housing (2 x, part of the additional headlight retrofit kit)
- W** Bracket lower section (2 x, part of the additional headlight bracket retrofit kit)
- X** Socket contact (only for cars with SA 5A2 or SA 5A4, part of the interface add-on kit)

## 2. Preparatory work

	<b>ISTA No.</b>
Disconnect the negative battery cable	61 20 900
<b>The following components must be removed first of all</b>	
Front bumper trim	51 11 ...
Cowl cover	---
(Interior) door sill cover strip, passenger side	51 47 000
Footwell side trim on the A-pillar, passenger side	51 43 075
Glove box	---
Steering column trim, lower section	---

### 3. Retrofit wiring harness connection diagram

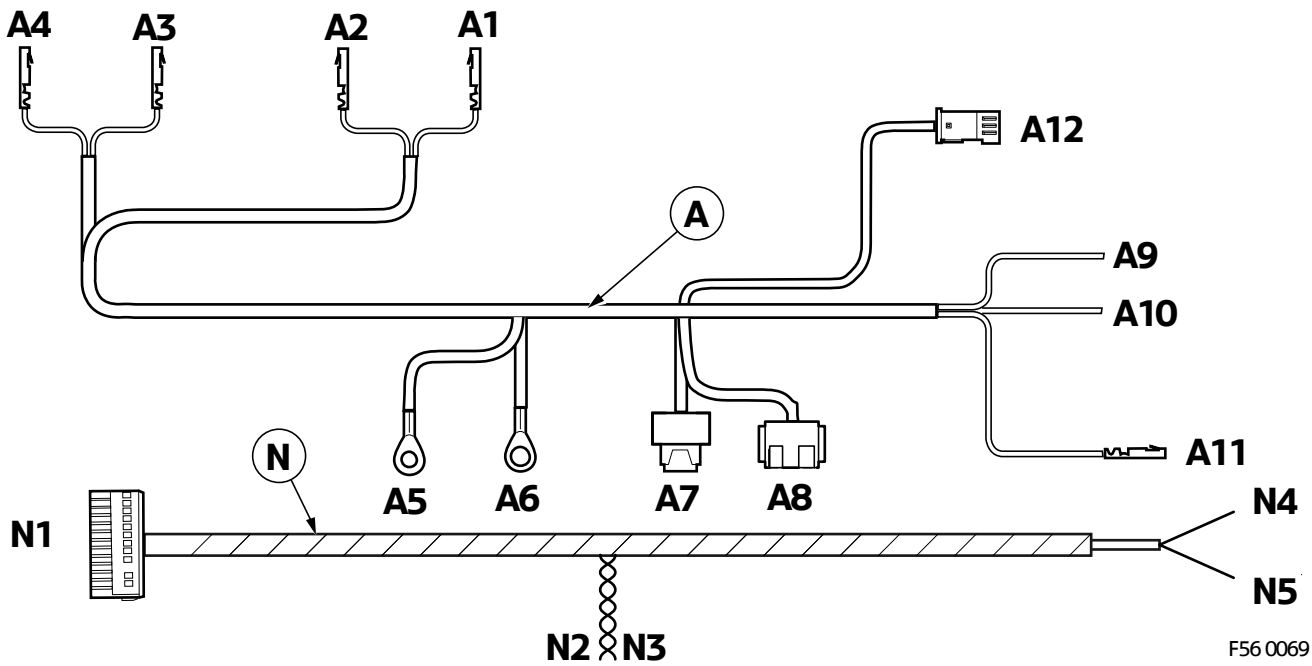

Item	Designation	Signal	Cable colour/ cross-section	Connection location in the car	Abbreviation/ slot
A	Retrofit wiring harness	---	---	---	---
A1	Socket contact	FSL	BL/RT 1.0 mm <sup>2</sup>	With socket casing <b>U</b> to pin housing <b>V</b> of left-hand additional headlight <b>C</b>	PIN 1
A2	Socket contact	Terminal 31	BR 1.0 mm <sup>2</sup>	With socket casing <b>U</b> to pin housing <b>V</b> of left-hand additional headlight <b>C</b>	PIN 2
A3	Socket contact	FSR	BL/WS 1.0 mm <sup>2</sup>	With socket casing <b>U</b> to pin housing <b>V</b> of right-hand additional headlight <b>C</b>	PIN 1
A4	Socket contact	Terminal 31	BR 1.0 mm <sup>2</sup>	With socket casing <b>U</b> to pin housing <b>V</b> of right-hand additional headlight <b>C</b>	PIN 2
A5	M6 ring eyelet	Terminal 31	BR	Screw onto ground support point next to DSC unit	Z10*2B
A6	M8 ring eyelet	Terminal 30	RT/BL 2.5 mm <sup>2</sup>	To terminal 30 support point on fuse holder in the interior	---
A7	Fuse holder	---	---	---	---
A8	SW 9-pin relay base	---	---	To control module <b>B</b>	---
A9	Open cable	Terminal 15	GR 0.75 mm <sup>2</sup>	With miniature connector <b>S</b> to the cable from the BDC	A258*3B PIN 20
A10	Open cable	Terminal 58g	GR/RT 0.75 mm <sup>2</sup>	With miniature connector <b>S</b> to the cable from the BDC	A258*7B PIN 28
A11	Open cable	Terminal 56a	GE/BL 0.75 mm <sup>2</sup>	<b>Only cars without SA 5A2 or SA 5A4</b> With miniature connector <b>S</b> to the cable from the BDC <b>Only cars with SA 5A2 or SA 5A4</b> With socket contact <b>X</b> in branch <b>N1</b>	A258*3B PIN 34 N1 PIN 6
A12	BL 4-pin socket casing	---	---	To button <b>Q</b>	---
N	Wiring harness interface	---	---	<b>Only cars with SA 5A2 or SA 5A4</b>	---
N1	SW 12-pin socket casing	---	---	To interface <b>M</b>	---
N2	Twisted cable	CAN High	GN/BL 0.35 mm <sup>2</sup>	With miniature connector <b>O</b> to the cable from the BDC	A258*8B PIN 44
N3	Twisted cable	CAN Low	GN 0.35 mm <sup>2</sup>	With miniature connector <b>O</b> to the cable from the BDC	A258*8B PIN 43
N4	Open cable	Terminal 15	RT 0.35 mm <sup>2</sup>	With miniature connector <b>O</b> to the cable from the BDC	A258*3B PIN 20
N5	Open cable	Terminal 31	BR 0.35 mm <sup>2</sup>	With miniature connector <b>O</b> to the cable from the BDC	A258*3B PIN 24

#### 4. Installation and cabling diagram

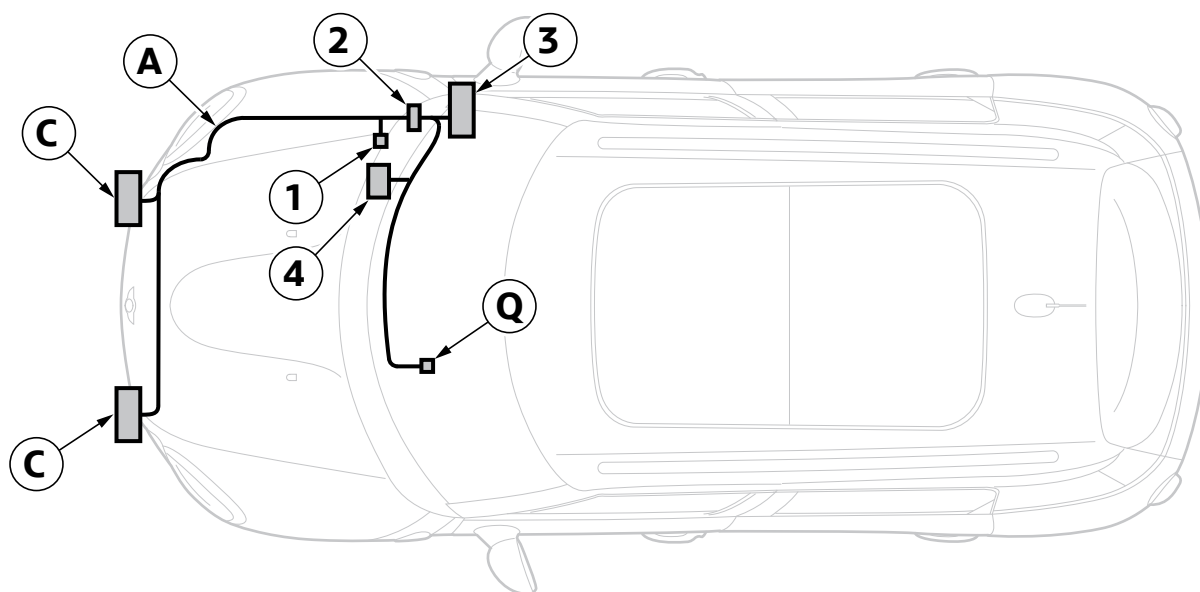

F56 0050 Z

- A** Retrofit wiring harness
- B** Junction point
- C** Additional headlight
- Q** Button
  
- 1** Ground support point **Z10\*2B**
- 2** Rubber grommet
- 3** Body Domain Controller (BDC) **A258**
- 4** Power distribution box in the interior compartment

## 5. Routing and connecting the retrofit wiring harness

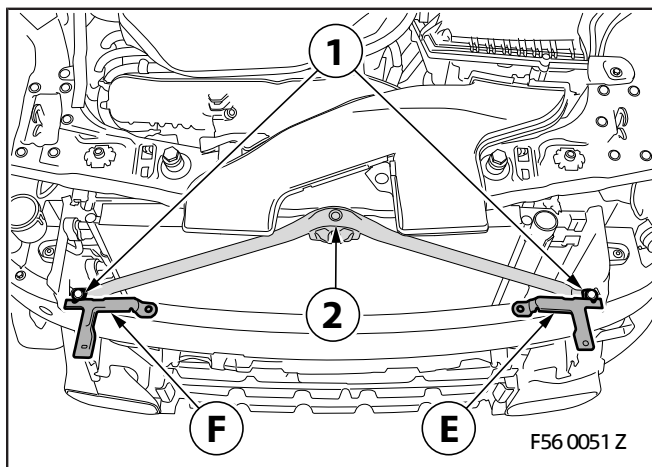

Unscrew the screws (1) on the reinforcing strut (2).  
Place additional headlight bracket E and F on top and screw on using screw (1) (do not tighten fully).

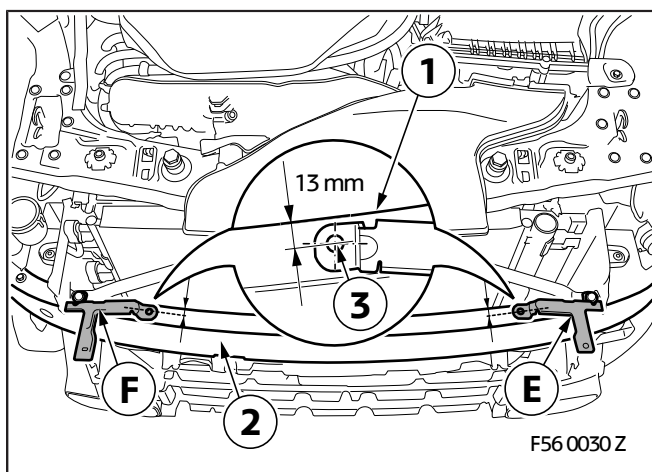

Draw on a dimension 13 mm from the edge (1) on the bumper trim support (2).

Push additional headlight bracket E and F over the cut-out line and draw on the drilling points (3).

Remove additional headlight holder E and F.

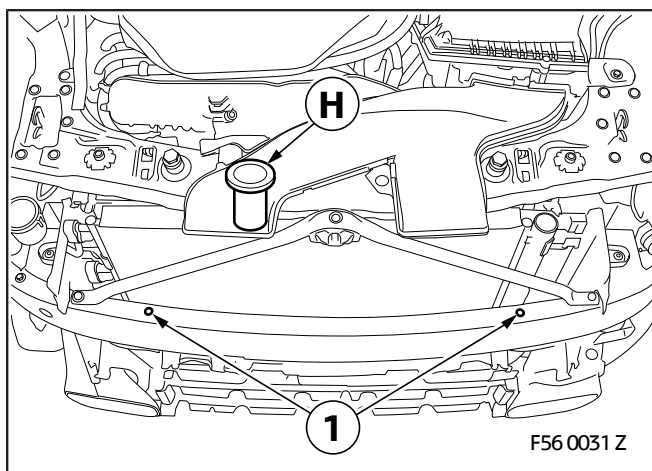

Drill through the holes (1) with a 9.1 mm diameter drill bit.

Insert rivet nuts H into the holes (1).

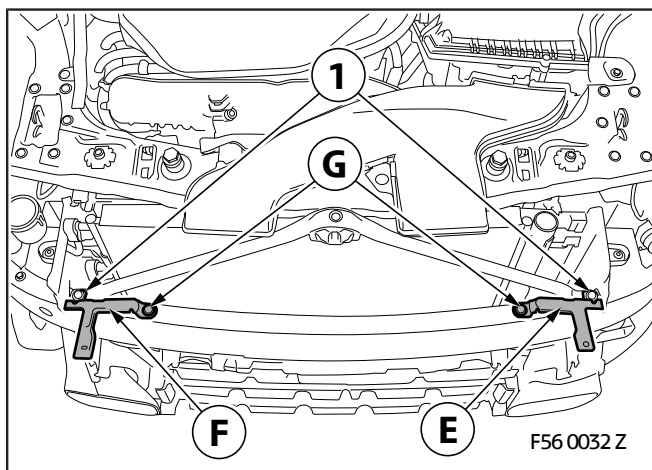

Screw on additional headlight holder E and F using pan head screws G and original screws (1).



## 5. Routing and connecting the retrofit wiring harness

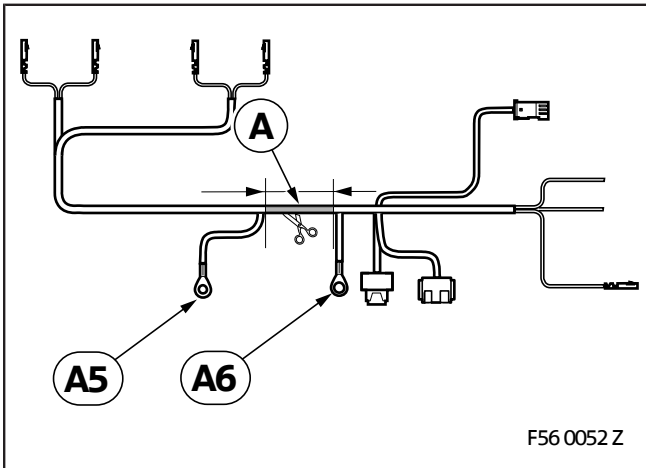

Wind up the cable around branch **A5** and **A6** of retrofit wiring harness **A**.

Wrap branch **A5** and **A6** individually using suitable insulating tape.

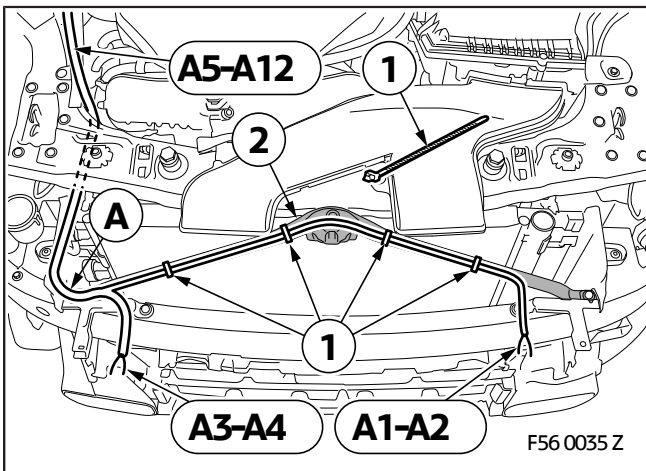

Route retrofit wiring harness **A** as follows:

- Branches **A1-A2** to the left additional headlight
- Branches **A3-A4** to the right additional headlight
- Branches **A5-A12** to the DSC unit installation point

Secure retrofit wiring harness **A** using usual workshop cable ties (1) to the reinforcing strut (2).

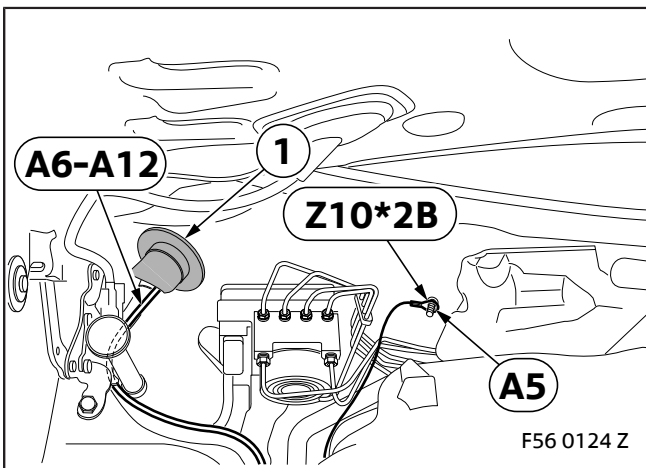

▶ To ensure a good ground connection, remove any paint from ground support point **Z10\*2B**.

Screw branch **A5** onto ground support point **Z10\*2B**.

Route branches **A6-A12** through the rubber grommet (1) into the interior of the car.

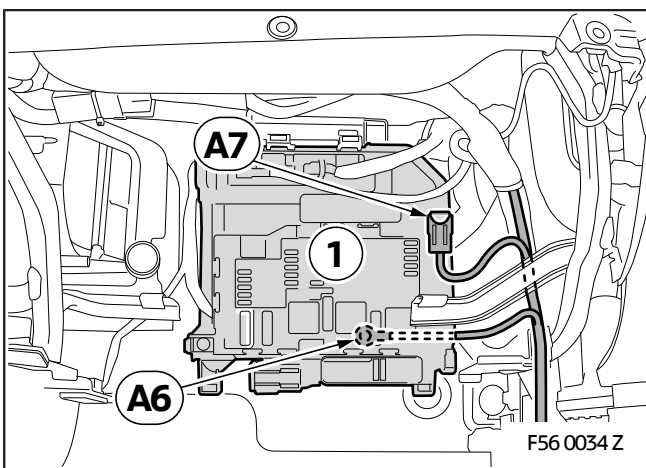

Release the fuse box (1) and place it to one side.

Screw on branch **A6** to the screw-on clamp of the fuse box (1).

Secure fuse holder **A7** in the area of the fuse box (1) using conventional cable ties.

## 5. Routing and connecting the retrofit wiring harness

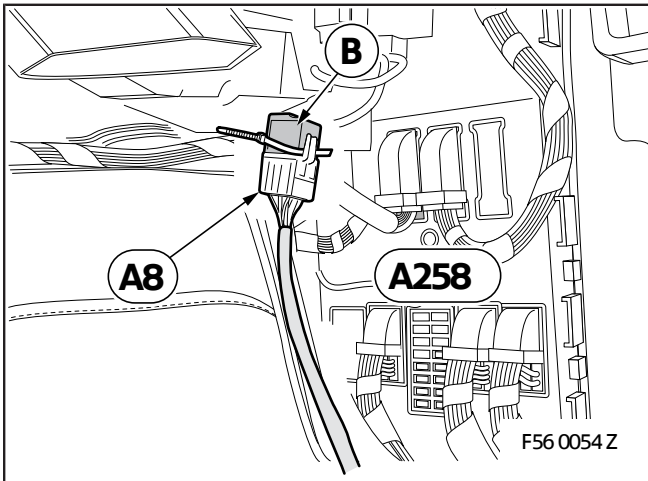

Connect control module **B** to branch **A8**.

Secure branch **A8** using suitable cable ties in the area of BDC **A258**.

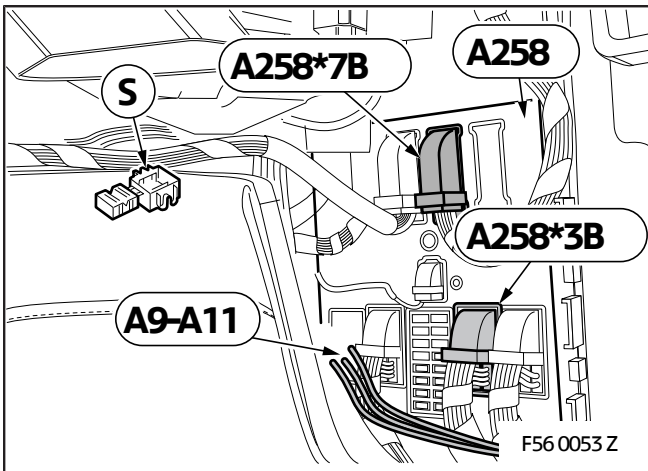

### Only cars without SA 5A2 or SA 5A4

Connect branches **A9-A11** as follows to BDC **A258** :

- Branch **A9**, GR cable, with miniature connector **S** to the cable from PIN 20 of plug **A258\*3B**
- Branch **A10**, GR/RT cable, with miniature connector **S** to the cable from PIN 28 of plug **A258\*7B**
- Connect branch **A11**, GE/BL cable, to PIN 34 of plug **A258\*3B**

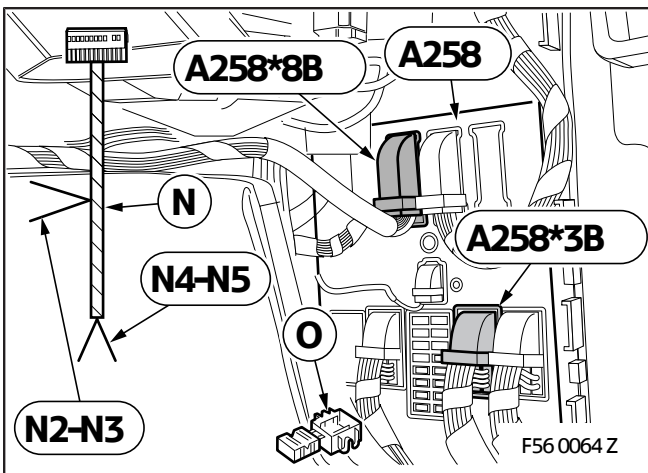

### Only cars with SA 5A2 or SA 5A4

Connect wiring harness interface **N** as follows to BDC **A258**:

- Branch **N2**, GN/BL cable, with miniature connector **O** to the cable from PIN 44 of plug **A258\*8B**
- Branch **N3**, GN cable, with miniature connector **O** to the cable from PIN 43 of plug **A258\*8B**
- Branch **N4**, RT cable, with miniature connector **O** to the cable from PIN 20 of plug **A258\*3B**
- Branch **N5**, BR cable, with miniature connector **O** to the cable from PIN 24 of plug **A258\*3B**

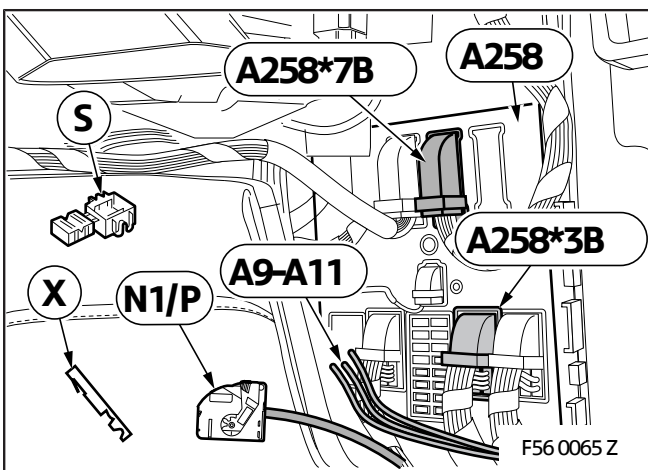

Connect branches **A9-A10** as follows to BDC **A258**:

- Branch **A9**, GR cable, with miniature connector **S** to the cable from PIN 1 of plug **A258\*3B**
- Branch **A10**, GR/RT cable, with miniature connector **S** to the cable from PIN 28 of plug **A258\*7B**

Crimp socket contact onto branch **A11**.

Connect branch **A11**, GE/BL cable, to PIN 6 of socket casing **N1**.

Push cover cap **P** onto branch **N1**.

## 5. Routing and connecting the retrofit wiring harness

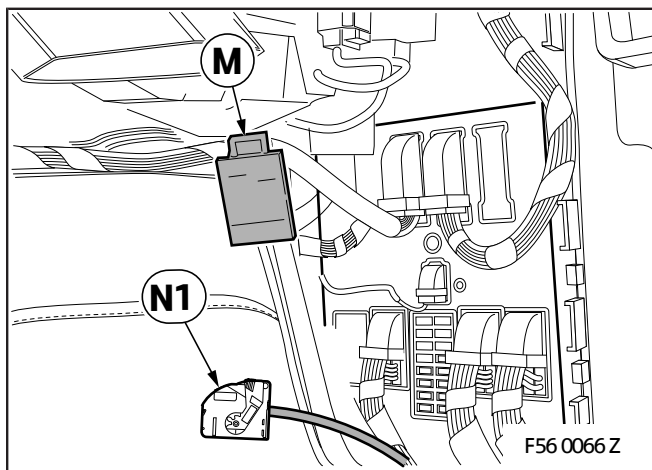

Connect branch **N1** to interface **M**.

Secure interface **M** at a suitable point.

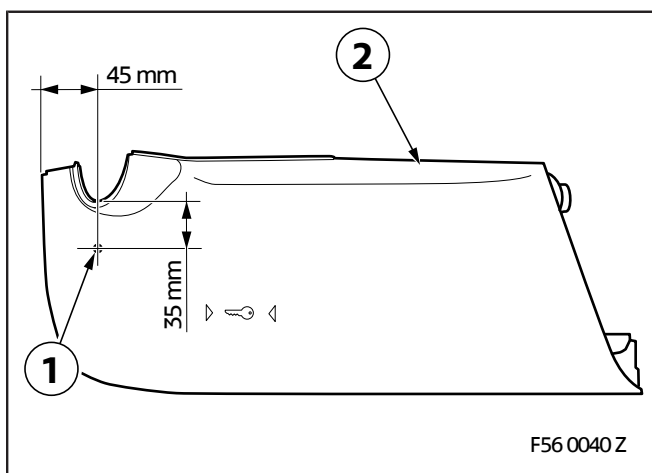

### All cars

▶ Carry out the drilling (1) gradually. ◀

Draw on the drilling point (1) on the steering column trim lower section (2) as per the dimensions.

Drill through the drilling point (1) with a 14 mm diameter drill bit.

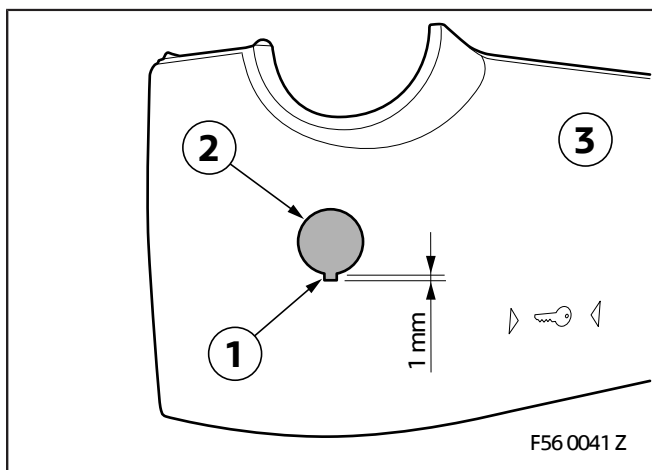

File out the cut-out (1) on the drill hole (2) as per the dimensions on the steering column trim lower section (2).

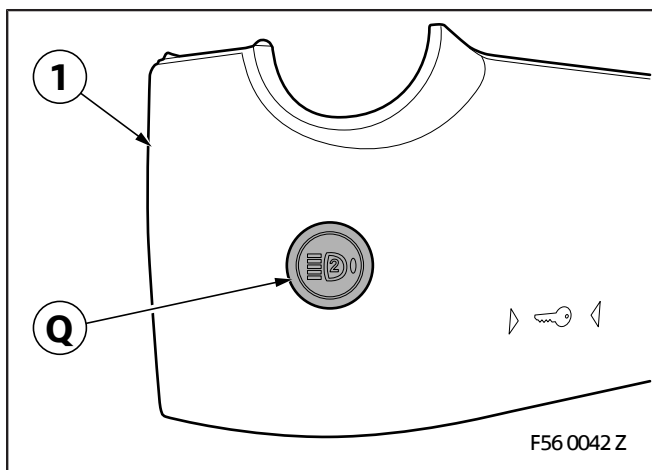

Clip button **Q** into the steering column trim lower section (1).

## 5. Routing and connecting the retrofit wiring harness

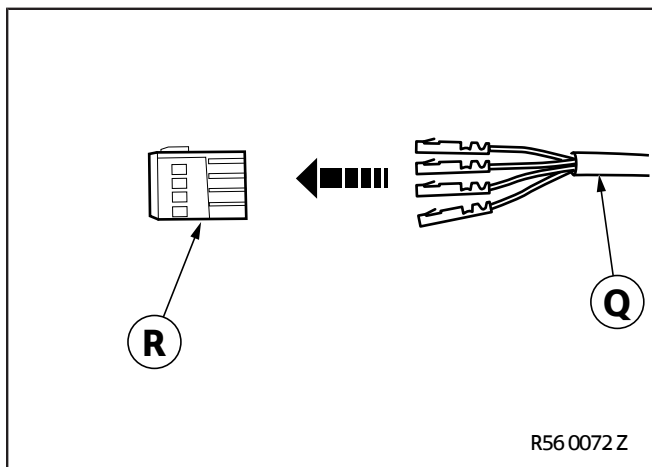

Connect the branches of button **Q** as follows to socket casing **R**:

- RT cable to PIN 1
- BR cable to PIN 2
- GN cable to PIN 3
- BL cable to PIN 4

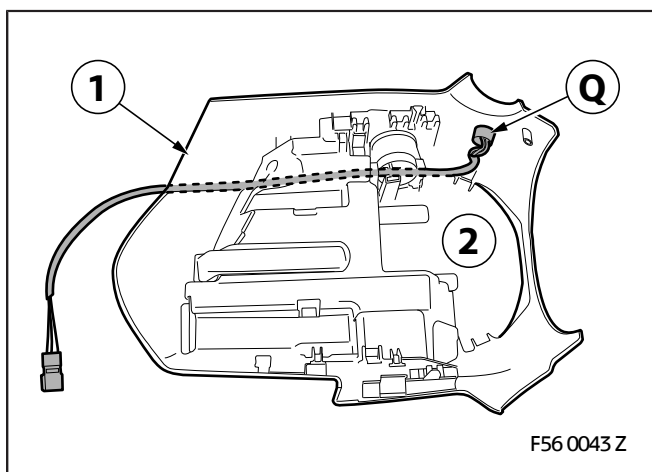

Route the cable from button **Q** below the foam insert of the steering column trim lower section (1).

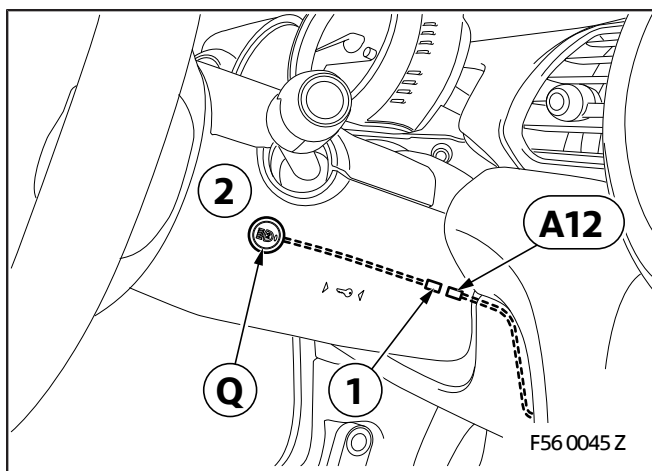

Route branch **A12** to the steering column.

Connect branch (1) of button **Q** to branch **A12** and install the steering column trim lower section (2).

## 6. Working with the bumper trim and installing the additional headlight

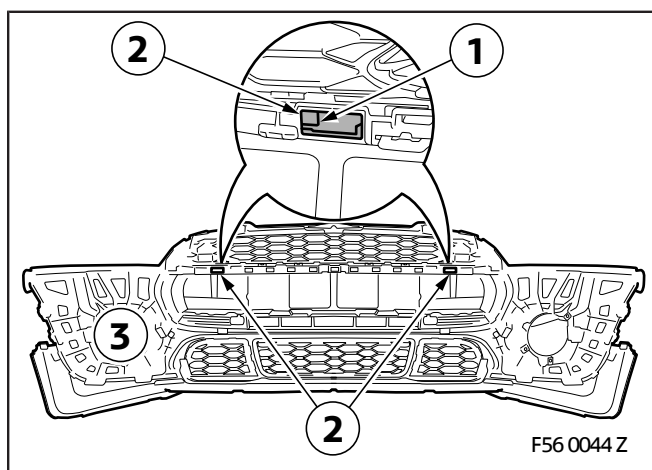

⚠ Danger of damage! Take extra care when working with the bumper trim (3). ◀

Trim any excess (1) on openings (2) in the bumper trim (3) using a suitable tool.

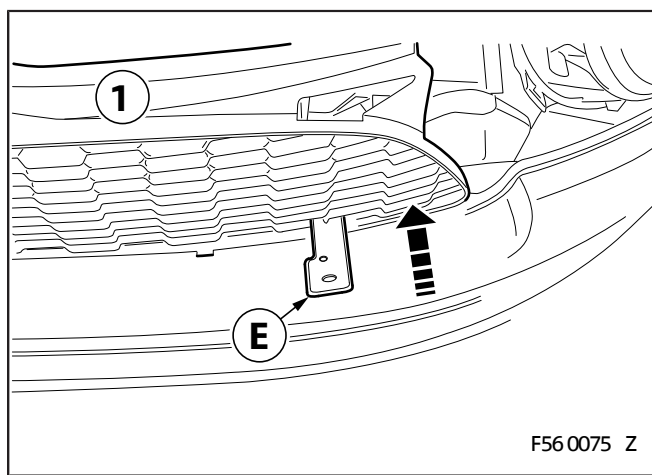

Push bumper trim (1) over additional headlight bracket E but do not secure into place yet.

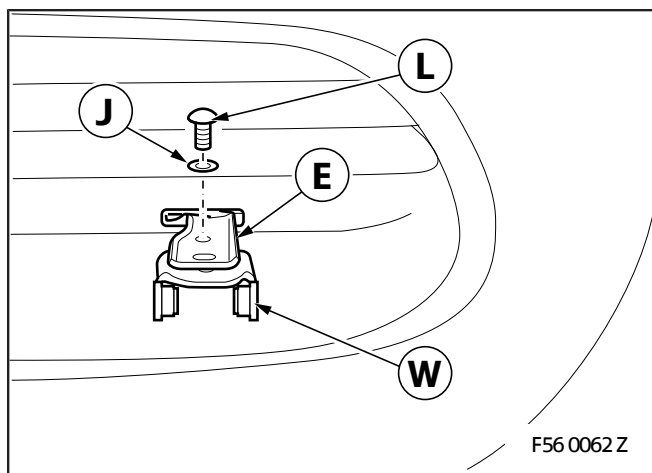

⚠ The installation steps are shown only on the left-hand side of the car, proceed in the same way on the right-hand side of the car. ◀

Screw bracket lower section W using spring washer J and screw L onto additional headlight bracket E.

## 6. Working with the bumper trim and installing the additional headlight

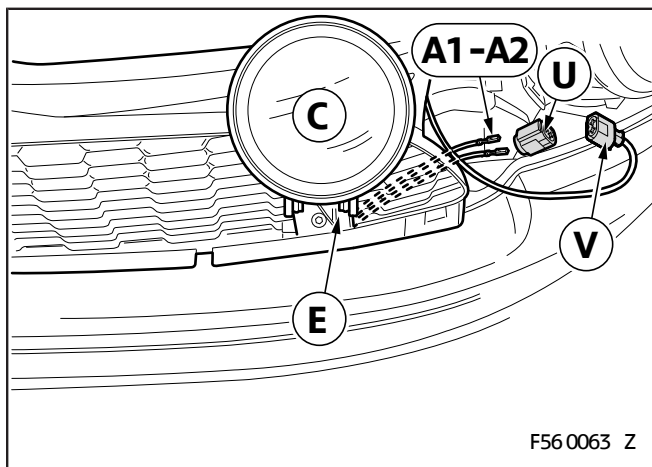

▶ Ask a second person to assist you with this step. ◀

Hold additional headlight **C** against additional headlight bracket **E** but do not secure in place yet.

Route branches **A1-A2** below additional headlight bracket **E** through the ornamental grille on the front bumper trim to socket casing **U**.

Connect branches **A1-A2** as follows to socket casing **U**:

- Branch **A1**, BL/RT cable, to PIN 1
- Branch **A2**, BR cable, to PIN 2

Connect cables from additional headlight **C** to pin housing **V** as follows:

- VI/SW cable to PIN 1
- BR cable to PIN 2

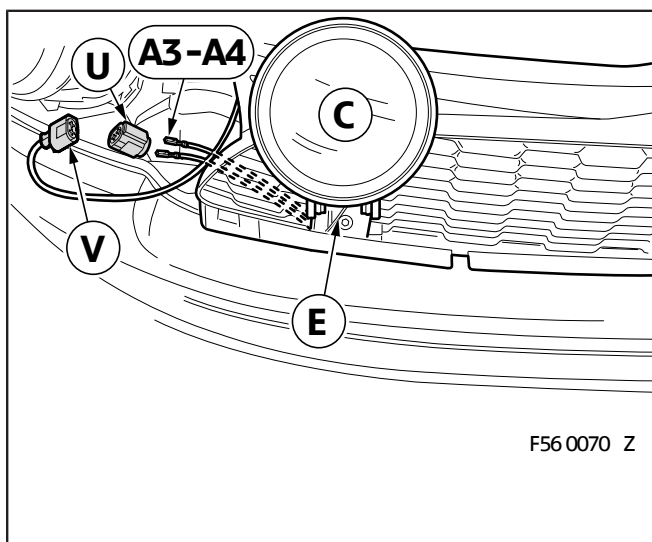

▶ Ask a second person to assist you with this step. ◀

Hold additional headlight **C** against additional headlight bracket **E** but do not secure in place yet.

Route branches **A3-A4** below additional headlight bracket **E** through the ornamental grille on the front bumper trim to socket casing **U**.

Connect branches **A3-A4** as follows to socket casing **U**:

- Branch **A3**, BL/WS cable, to PIN 1
- Branch **A4**, BR cable, to PIN 2

Connect cables from additional headlight **C** to pin housing **V** as follows:

- VI/SW cable to PIN 1
- BR cable to PIN 2

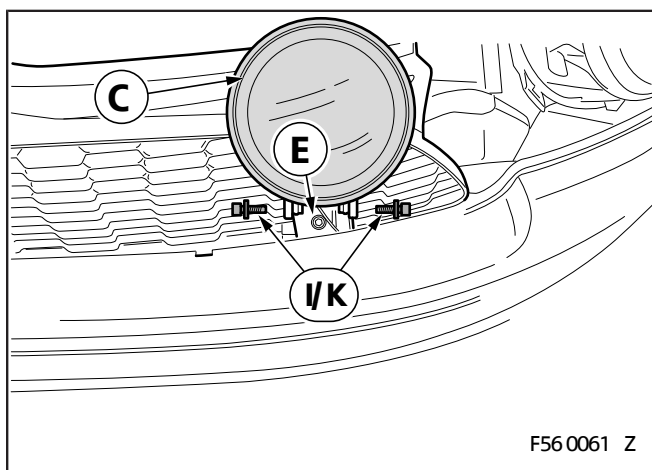

▶ The installation steps are shown only on the left-hand side of the car, proceed in the same way on the right-hand side of the car.

The tightening torque for screws **K** is 12 Nm. ◀

Secure the bumper trim.

Place additional headlight **C** on additional headlight bracket **E** and screw on using spring washers **I** and screws **K**.

## 7. Concluding work and coding

The retrofit system does not require programming / coding.

- Connect the battery
- Conduct a function test
- Re-assemble the car in a logical manner
- Give the customer the customer information

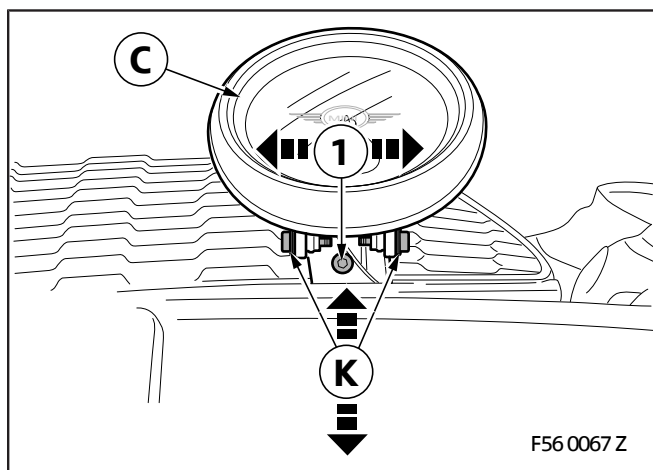

▣ The tightening torque for screws (1) and **K** is 12 Nm. ◀

Adjust additional headlight **C** as follows with the headlight adjustment tool:

### Vertical adjustment

Loosen the screw (1) and adjust the vertical setting

### Horizontal adjustment

Loosen both screws **K** and adjust the horizontal setting

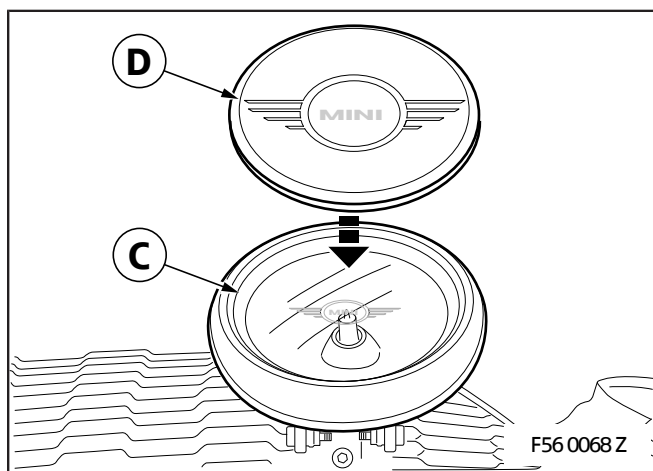

⚠ Risk of damage from overheating. Never use additional headlight **C** when cover caps **D** are fitted. ◀

Place cover caps **D** on additional headlights **C**.

## 8. Wiring diagram

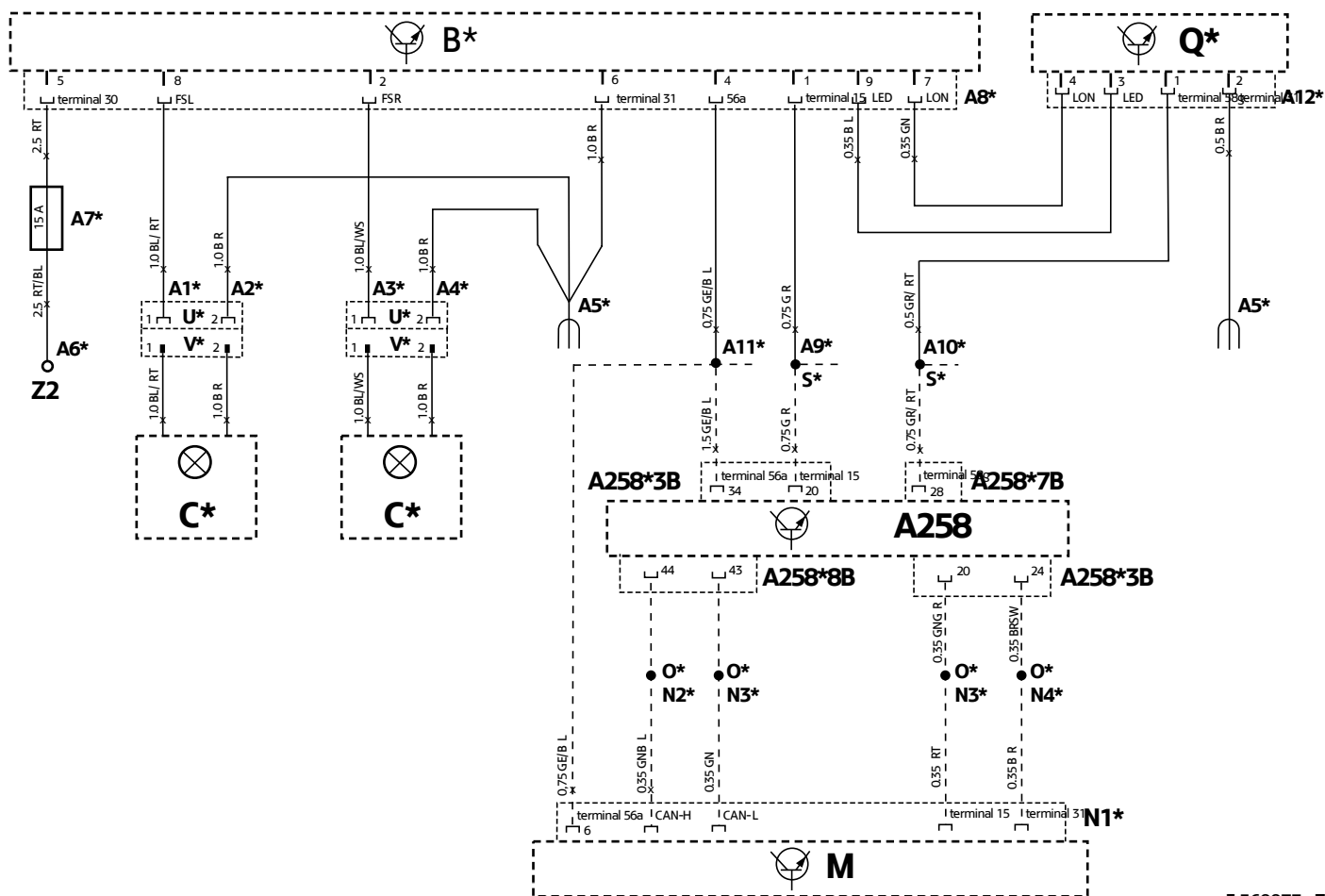

F 560073 Z

### Legend

- A1\*** Socket contact, BL/RT cable
- A2\*** Socket contact, BR cable
- A3\*** Socket contact, BL/WS cable
- A4\*** Socket contact, BR cable
- A5\*** M6 ring eyelet, BR cable
- A6\*** M8 ring eyelet, RT/BL cable
- A7\*** Fuse holder
- A8\*** SW 9-pin relay base
- A9\*** Open cable, GR cable
- A10\*** Open cable, GR/RT cable
- A11\*** Open cable, GE/BL cable
- A12\*** BL 4-pin socket casing

- N1\*** SW 12-pin socket casing
- N2\*** Open cable, GN/BL cable
- N3\*** Open cable, GN cable
- N4\*** Open cable, RT cable
- N5\*** Open cable, BR cable

- B\*** Control module
- C\*** Additional headlight
- M\*** Interface (only cars with SA 5A2 or SA 5A4)
- O\*** Miniature connector (only cars with SA 5A2 or SA 5A4)
- Q\*** Button
- S\*** Miniature connector



## 8. Wiring diagram

**U\*** SW 2-pin socket casing  
**V\*** SW 2-pin pin housing

**A258** Body Domain Controller BDC  
**A258\*3B** SW 54-pin socket casing  
**A258\*7B** NT 54-pin socket casing  
**A258\*8B** SW 54-pin socket casing  
**Z2** Power distribution box in the interior compartment  
**Z10\*2B** Ground support point in the engine compartment



All the designations marked with an asterisk (\*) apply only to these installation instructions or this wiring diagram.

### Cable colours

BL	Blue	GR	Grey	RT	Red
BO	Bordeaux (Burgundy)	L-GN	Light green	SW	Black
BR	Brown	NT	Natural	TR	Transparent
GE	Yellow	OR	Orange	VI	Violet
GN	Green	RO	Pink	WS	White

## 9. Customer information

### Explanation of pictograms

-  Denotes instructions that draw your attention to dangers.
-  Denotes instructions that draw your attention to special features.
-  Denotes the end of the instruction or other text.

 **Risk of damage from overheating! Never use the additional headlights when the headlight covers are fitted.** ◀

 Consult the applicable state and regional laws governing the use of additional headlights. Some countries, for instance, forbid the simultaneous use of four lights, while others ban their use on public roads altogether and require that the additional headlights are equipped with optional headlight covers when not in use. ◀

### Operating the additional headlights

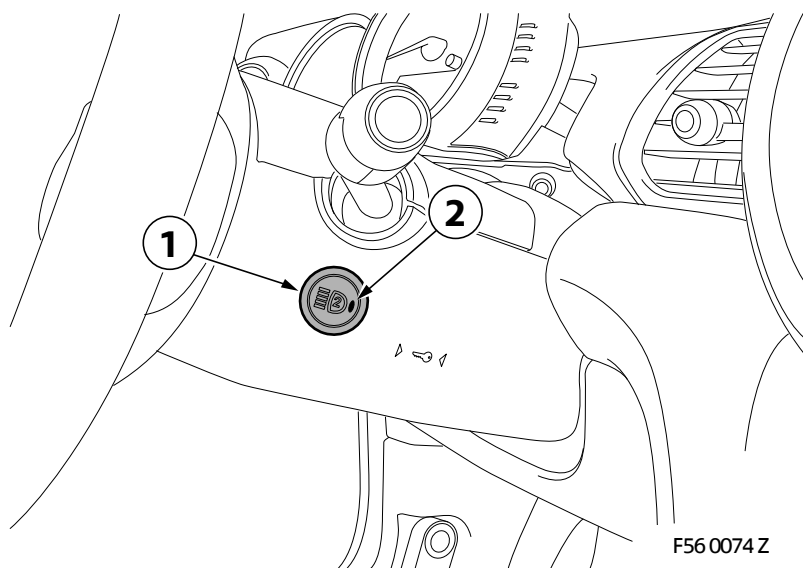

 Once activated, the additional headlights light up automatically when the headlights or headlight flash are switched on. Whenever you turn the ignition off/on, you must re-activate the additional headlights. ◀

### Switching the additional headlights on automatically

- Switch on the ignition or start the engine
- Press the button (1) to activate
- The additional headlights are activated when the green control light (2) lights up in the button (1)
- Switch the headlights on or actuate the headlight flash

The additional headlights light up along with the headlights or headlight flash

### Switching the additional headlights on manually

- Switch on the ignition or start the engine
- Switch the headlights on or actuate the headlight flash
- Press the button (1) to switch on the additional headlights

The additional headlights light up along with the headlights or headlight flash

### Switching off the headlights

Switch off the headlights or press the button (1) again.

## 9. Customer information

### Changing the bulb

Lamps and lights are an important part of the car's safety features. Appropriate care should therefore be used when handling them. If you are not familiar with such work, have it performed by your MINI service centre.

▣ Bulb required: **H3** (55 W). Do not touch the glass rounded section of the bulb with your bare hands, since even slight contamination can burn onto the surface and reduce the bulb's service life. Use a clean cloth, a paper towel or similar to take hold of the bulb at its base. ◀

⚠ When carrying out any work on the car's electrical system, switch off the device you are working on or disconnect the battery's negative terminal, otherwise you may cause a short-circuit. Always read any instructions provided by the bulb's manufacturer in order to avoid injury and/or damage when changing the bulb. ◀

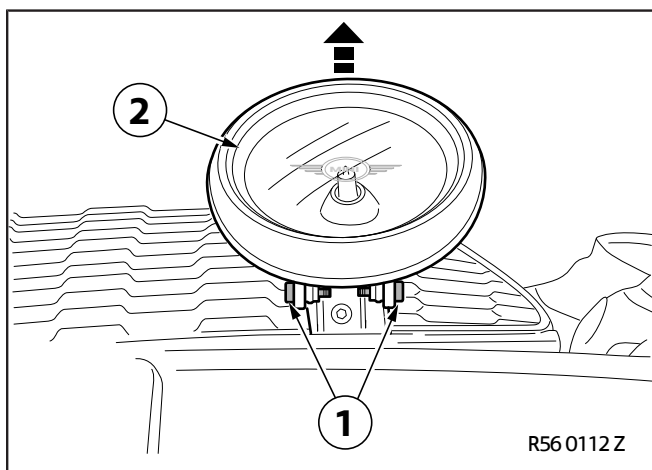

Unscrew both screws (1) and pull the additional headlight (2) carefully forwards.

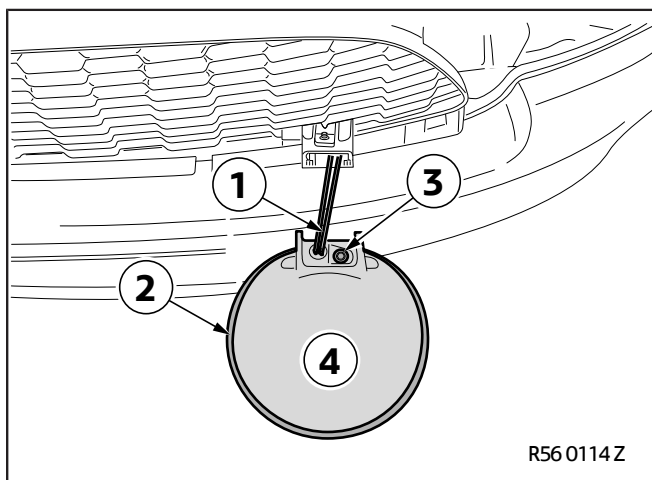

▣ In order to avoid damaging the cable (1), hold the additional headlight (2) with one hand. ◀

Unscrew the Allen screw (3) and remove the housing (4).

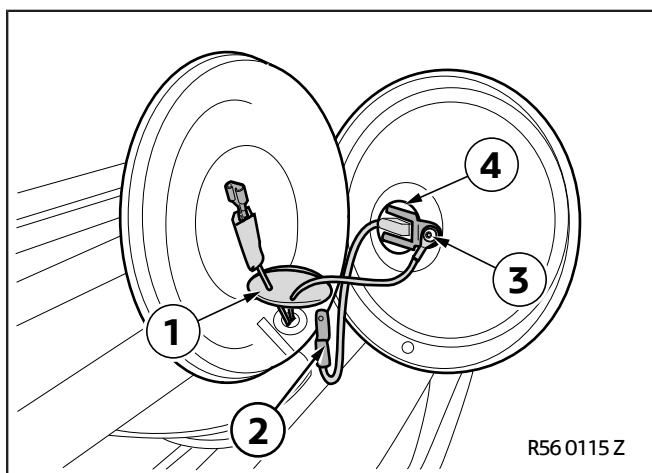

▣ The tightening torque for the screws is 12 Nm. The position of the additional headlight must be adjusted after the bulb has been changed. ◀

Remove the rubber cap (1) and disconnect the plug (2).

Loosen the screw (3), remove it and change the bulb (4).

The headlight is reassembled in the reverse order.

## 9. Customer information

### Adjusting the additional headlights

☒ Have the additional headlights adjusted by your MINI dealer.

If you are unable to visit your MINI dealer, you can temporarily adjust the additional headlights yourself even without the headlight adjusting tool. The steps for how to do this are described using the example of the left-hand additional headlight. The right-hand additional headlight is adjusted in exactly the same way.

To adjust the headlights, park your unladen car on even ground and around 5 - 10 m perpendicularly to a vertical wall. ◀

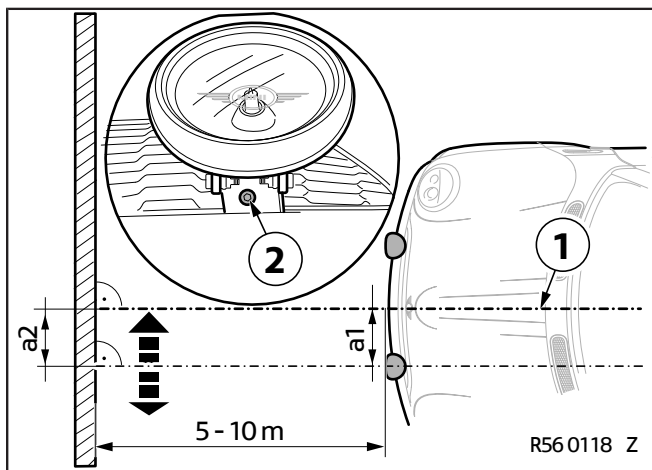

#### Testing the vertical setting

☒ The tightening torque for the screw (2) is 12 Nm. ◀

- Measure the distance **a1** from the centre of the cone of light on the wall to the extension of the vehicle's longitudinal axis (1)
- Measure the distance **a2** from the centre of the cone of light on the wall to the extension of the vehicle's longitudinal axis (1)

If distances **a1** and **a2** are not identical, adjust the vertical position as follows:

#### Adjusting the vertical position

- Loosen the screw (2) and rotate the additional headlight so that distances **a1** and **a2** are the same
- Tighten the screw (2) to 12 Nm

#### Testing the horizontal setting

☒ The tightening torque for the screw (1) is 12 Nm. ◀

- Measure the height **h1** from the centre of the additional headlight to the floor
- Measure the height **h2** from the centre of the cone of light on the wall to the floor

If heights **h1** and **h2** are not identical, adjust the horizontal position as follows:

#### Adjusting the horizontal position

- Loosen both screws (1) and rotate the additional headlights so that heights **h1** and **h2** are the same
- Tighten the screws (1) to 12 Nm

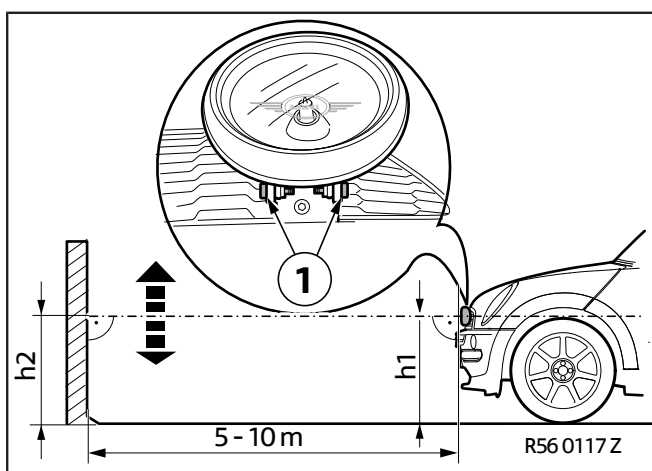

### Cleaning and care

Use a soft damp cloth to clean the additional headlights. Do not use abrasive or corrosive cleaning agents.