



SUBJECT

Installation of Right-Hand Drive Steering Spindle in Left-Hand Drive Vehicle

MODEL

R50 (Cooper)

R52 (Cooper Convertible, Cooper S Convertible)

R53 (Cooper S)

SITUATION

Supply shortage of left-hand drive steering spindles

CORRECTION

The installation of the right-hand drive steering spindle is possible in left-hand drive vehicles. Follow the conversion steps below:

1. Remove the steering spindle per Repair Instruction 3231070 (REP-RAR5032-3231070, Removing and installing or replacing lower section of steering spindle).

NOTE: The fork on the right-hand drive steering spindle (to be installed) is turned by 38 degrees.

IMPORTANT: Identify the version of steering column fitted in the vehicle!

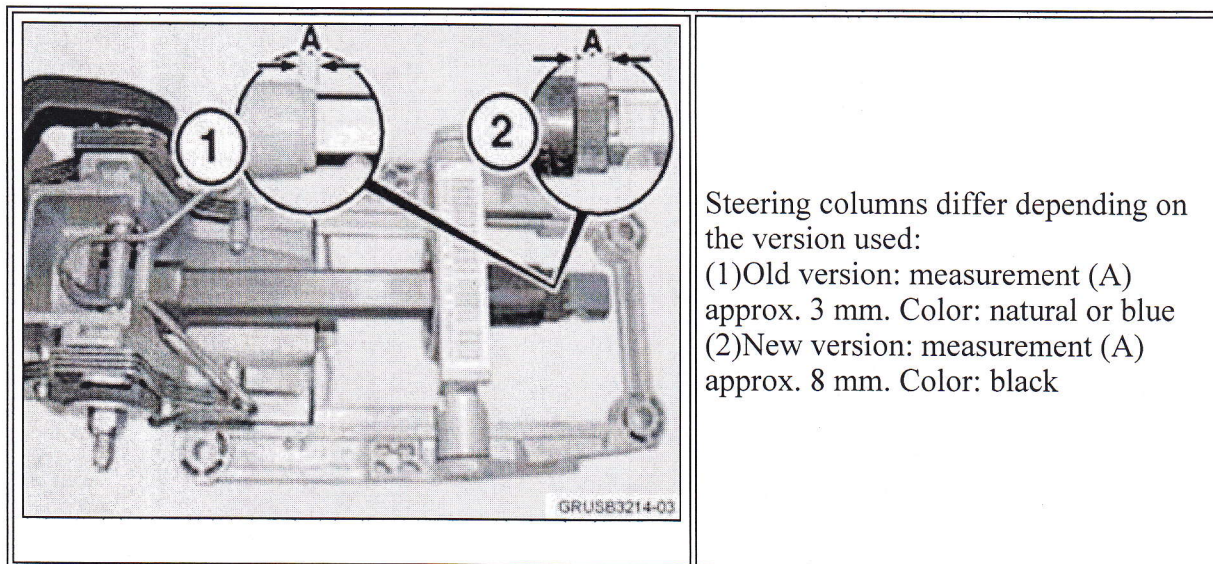

2. After connecting the steering spindle to the column, open the steering lock and turn the steering shaft in the engine compartment counterclockwise (looking from the front of the vehicle) by 38 degrees, so that you can fit the fork to the steering rack.



The steering wheel is now turned clockwise by 38 degrees, or seven teeth.

3. Remove the airbag and the steering wheel per Repair Instruction 3233000 (REP-RAR5032-3233000, Removing and installing/replacing steering wheel). Turn the coil spring 38 degrees counterclockwise and bring it into the straight-ahead position. To do this, refer to Repair Instruction 6131006 (REP-RAR5061-6131006, Remove and refit bracket for steering column switch).

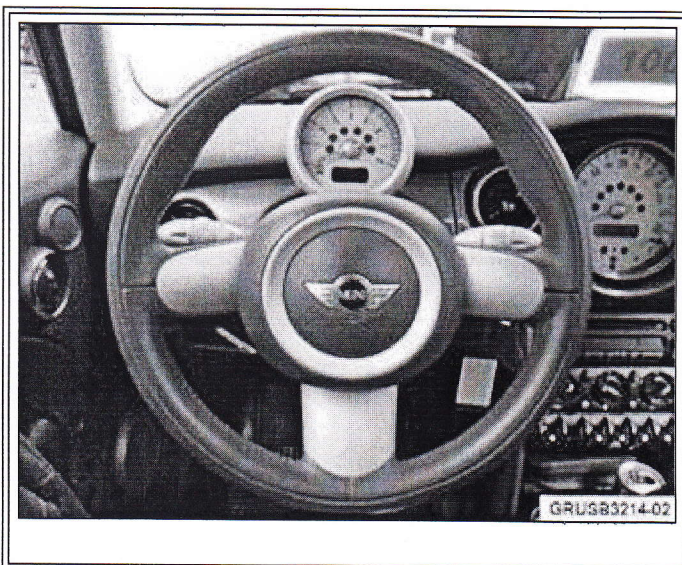

Install the steering wheel so it is straight (turned counterclockwise by seven teeth).
IMPORTANT: Be sure to mark the steering column and steering wheel to the new center alignment position. Refit as per the repair instructions.

4. For vehicles with DSC, reinitialize the steering angle.
5. Once completed, check that the steering wheel position is correct when driving in a straight line.

When fitted correctly, it is not necessary to perform a wheel alignment or realign the steering wheel by setting the steering track rods.

PARTS INFORMATION

Part Number	Description	Quantity

32 30 6 763 727	Steering spindle	1
32 20 6 782 616	Self-locking nut	1
32 30 6 758 080	M8x35 Hex bolt	1

WARRANTY INFORMATION

Not applicable.

ATTACHMENTS

View PDF attachment [M320214_3231070](#).

View PDF attachment [M320214_3233000](#).

View PDF attachment [M320214_6131006](#).

[Copyright ©2014 BMW of North America, Inc.]

REP-REP-RAR5032-3233000 Removing and installing/replacing steering wheel

VIN: Vehicle: MINI / R50 / Coupe / Cooper / W10 / USA / left-hand drive / AUT / - /

System version: 1.1.6 Data version: 3.44

32 33 000

Removing and installing/replacing steering wheel

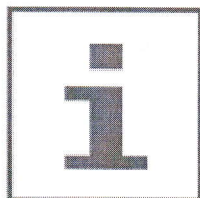

Necessary preliminary tasks:

- Move wheels into straight-ahead position
- Remove airbag unit

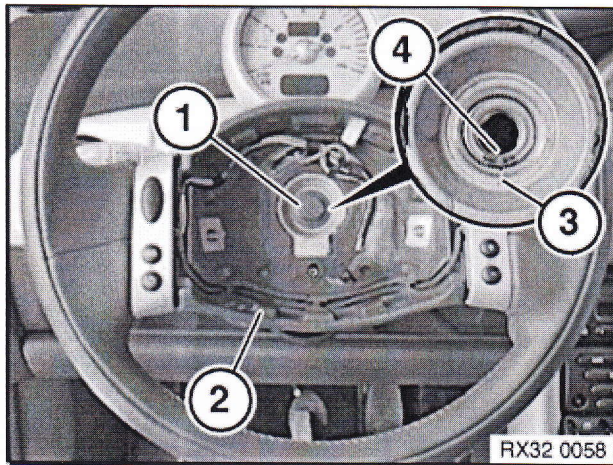

Release screw (1) and remove steering wheel (2).

Installation:

Tightening torque 32 33 1AZ.

Make sure that the road wheels stay in the straight-ahead position.

Mount steering wheel.

Marks on steering wheel (3) and steering spindle (4) must coincide.

Warning!

Secure volute spring cassette (1) against rotating with adhesive tape (2).

If unauthorized rotation of volute spring

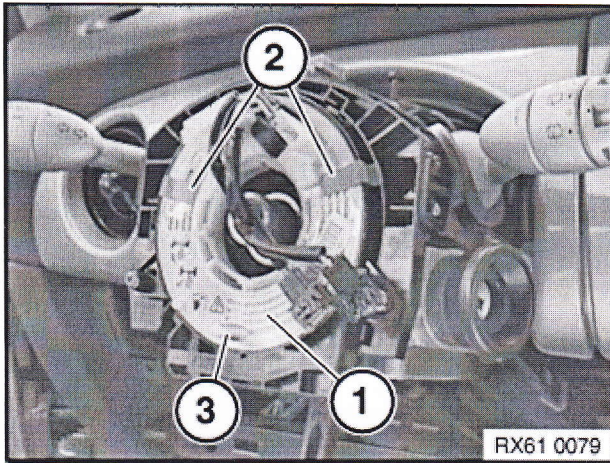

cassette (1) cannot be ruled out, it is essential to return volute spring cassette (1) to center position!

- Turn volute spring counterclockwise as far as it will go.
- Turn volute spring clockwise as far as it will go.
- Turn volute spring back to center position and secure so that centering pin (3) is at bottom position.