

ORIGINAL MINI ACCESSORIES. INSTALLATION INSTRUCTIONS.



Mud Flaps Retrofit Kit.

MINI Countryman (F60)

Retrofit kit number

82 16 2 410 137 Front mud flaps set

82 16 2 410 138 Rear mud flaps set

Installation time

The installation time is **approx. 0.5 hours** per set. This may vary depending on the condition of the vehicle and its equipment.

The installation time shown does not include any time spent on programming/coding.

The calculation of the total costs for the programming time must be factored into the calculation of retrofitting costs (no invoicing via warranty).

Important information

These installation instructions are primarily intended for use within the BMW dealership organisation and by authorised MINI service companies.

In any event the target group for these installation instructions is specialist personnel trained on MINI cars with the appropriate specialist knowledge.

All work must be completed using the latest MINI repair manuals, wiring diagrams, servicing manuals and work instructions, in a rational order, using the prescribed tools (special tools) and observing current health and safety regulations.

If you experience installation or function problems, restrict troubleshooting to approx. 0.5 hours for mechanical work and 1.0 hour for electrical work.

To avoid unnecessary extra work and/or costs, send an inquiry straight away to the technical parts support team via the Aftersales Assistance Portal (ASAP).

Quote the following information:

- Vehicle identification number,
- Retrofit kit part number,
- A detailed description of the problem,
- Any work already carried out.

Do not archive the hard copy of these installation instructions since daily updates are provided via ASAP!

Pictograms



Denotes instructions that draw your attention to dangers.



Denotes instructions that draw your attention to special features.



Denotes the end of the instruction or other text.

Installation information

All pictures show LHD cars; proceed accordingly on RHD cars.

Some of the installation is shown only on the left-hand side of the car, proceed in the same way on the right-hand side of the car.

Special tools required

None

Table of contents

Section	Page
1. Front mud flaps parts list	4
2. Rear mud flaps parts list	5
3. Preparatory work	6
4. Fitting the front mud flaps	7
5. Fitting the rear mud flaps	9

1. Front mud flaps parts list

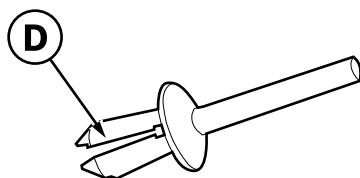
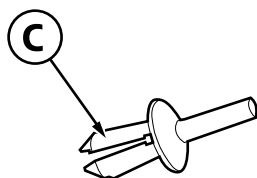
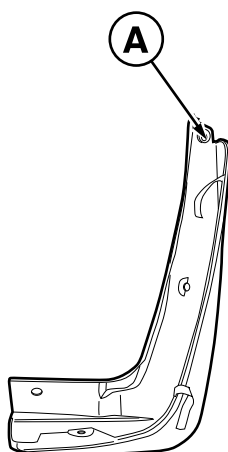
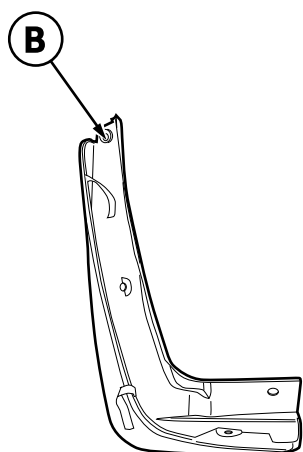

F60 0002 V

Legend

- A** Front left mud flap
- B** Front right mud flap
- C** Blind rivet, short (4 x)
- D** Blind rivet, long (4 x)

2. Rear mud flaps parts list

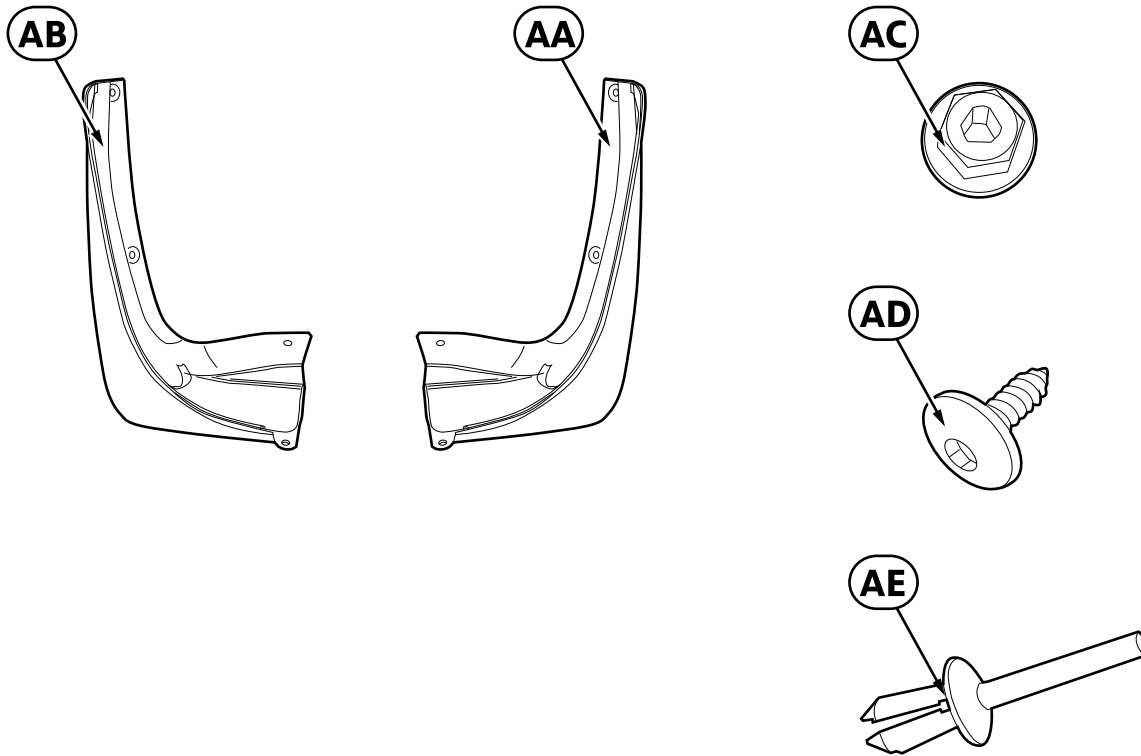

F60 0003 V

Legend

- AA** Rear left mud flap
- AB** Rear right mud flap
- AC** Cap nut (2 x)
- AD** Screw (2 x)
- AE** Blind rivet (6 x)

3. Preparatory work

	ISTA No.
The following components must be removed first of all	
None	---

4. Fitting the front mud flaps

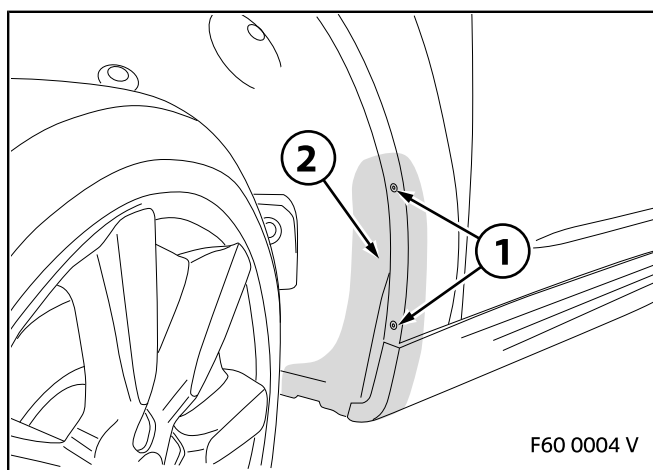

▶ The areas being bonded must be completely dry, clean and free from wax or grease. ◀

Remove the blind rivets (1) using suitable tools.

Clean the bonding surface (2) with suitable products.

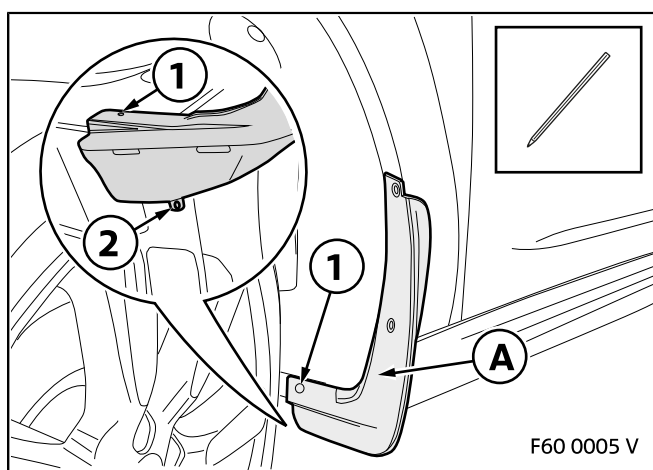

Position the front mud flap **A** and mark the boreholes (1) and (2) on the car using suitable tools.

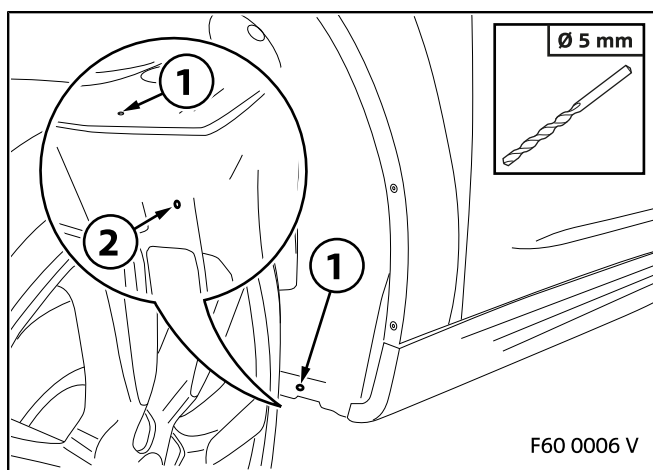

Remove the front mud flap **A** and drill holes at the marks (1) and (2) with a **diameter of 5 mm**.

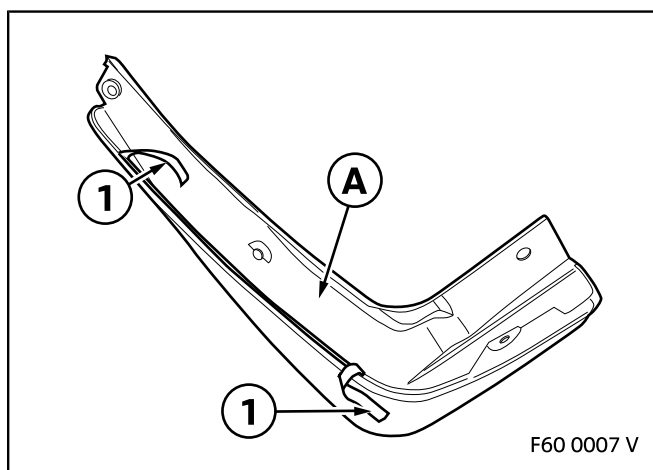

Bend the ends of the backing film (1) to the outside

4. Fitting the front mud flaps

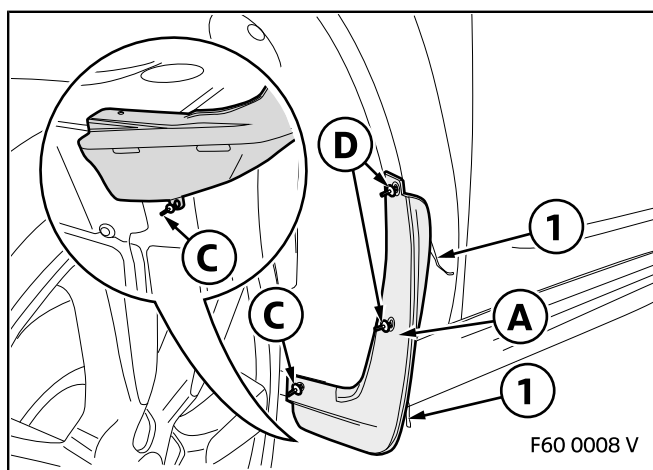

▶ Ensure that all tabs (1) on the adhesive backing film are visible. ◀

Fit the front mud flap **A** and secure it with two blind rivets **C** and to blind rivets **D**.

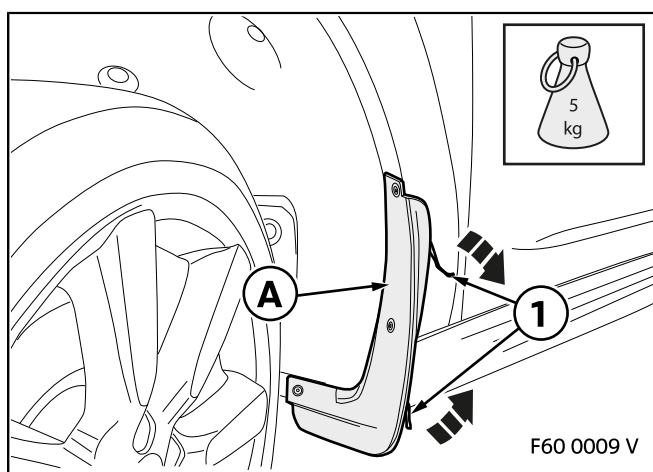

Pull off the tabs (1) and push the front mud flap **A** against the contour of the car several times.

5. Fitting the rear mud flaps

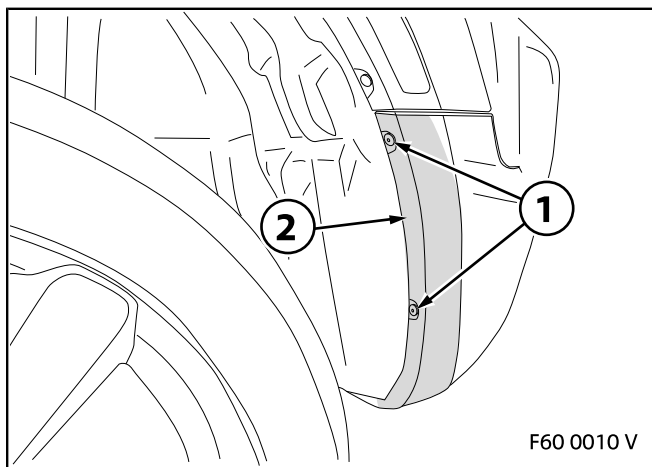

☐ The areas being bonded must be completely dry, clean and free from wax or grease. ◀

Remove the blind rivets (1) using suitable tools.

Clean the bonding surface (2) with suitable agents.

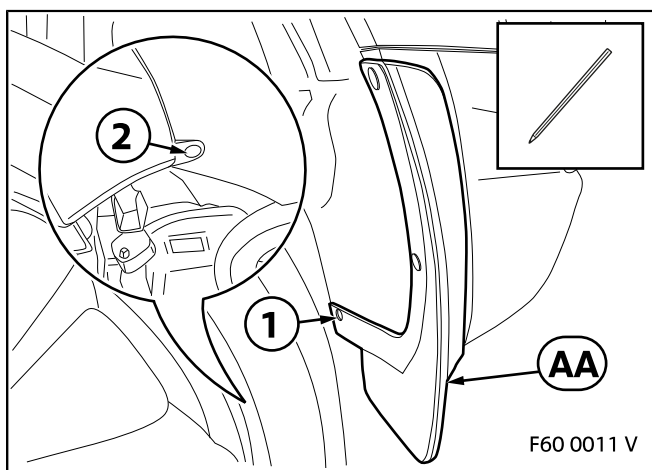

Position the rear mud flap **AA** and mark the boreholes (1) and (2) on the car using suitable tools.

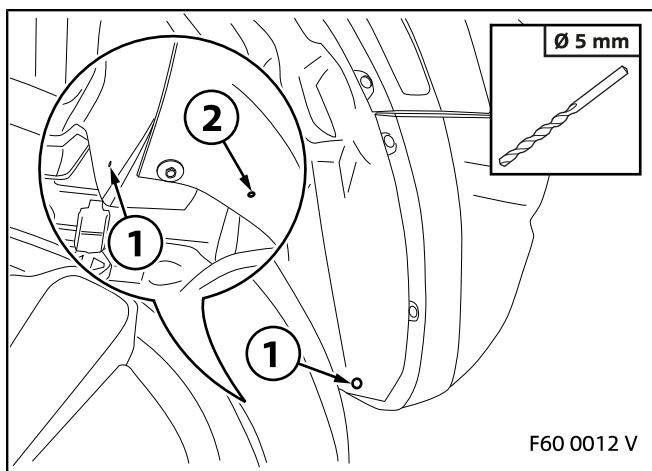

Remove the rear mud flap **AA** and drill holes at the marks (1) and (2) with a **diameter of 5 mm**.

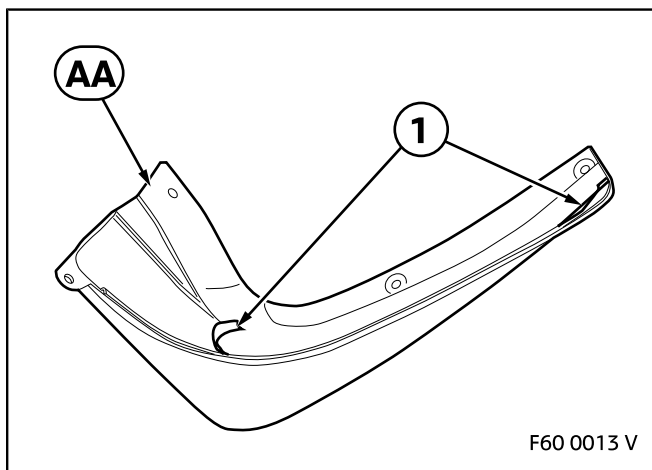

Bend the ends of the backing film (1) to the outside

5. Fitting the rear mud flaps

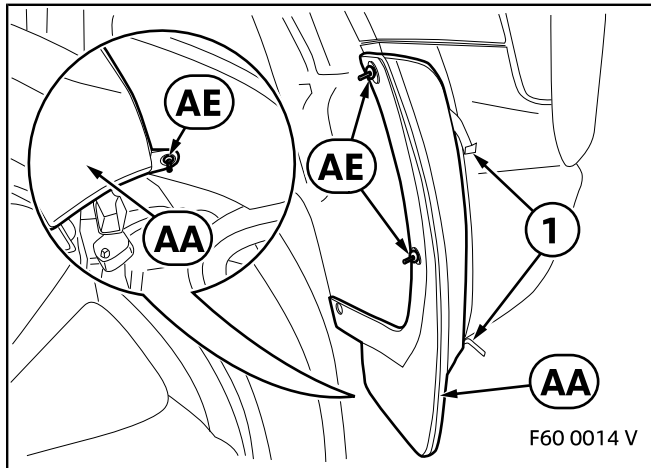

☐ Ensure that all tabs (1) on the adhesive backing film are visible. ◀

Fit the rear mud flap **AA** and secure it with three blind rivets **AE**.

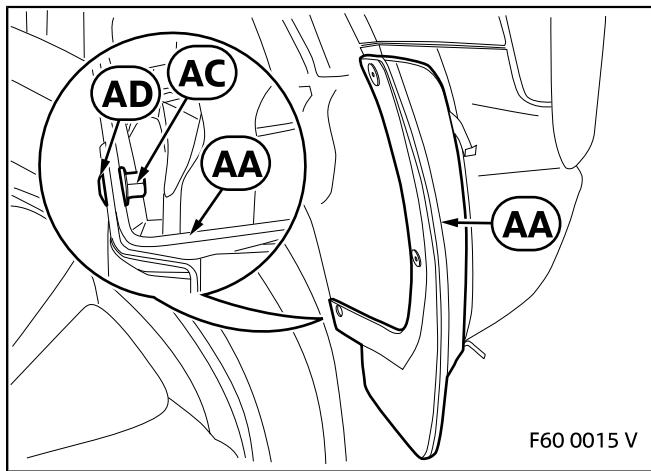

Place screw **AD** from outside through the borehole through the rear mud flap **AA** and secure it from the inside with cap nut **AC**.

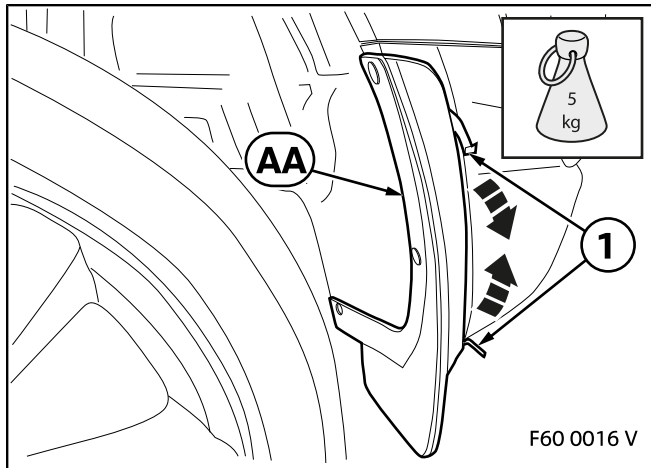

Pull off the tabs (1) and push the rear mud flap **AA** against the contour of the car several times.