

Original MINI Accessories.

Installation instructions.



Retrofit Auxiliary High-Beam Headlights

MINI One (R50)

MINI Cooper (R50)

MINI Cooper S (R53)

MINI One Convertible (R52)

MINI Cooper Convertible (R52)

MINI Cooper S Convertible (R52)

Retrofit Kit No.: 63 12 0 144 132, High-Beam Headlights

Installation time

The installation time is approx. 2.5 hours, but may vary depending on the condition of the car and the equipment in it.

Important information

These installation instructions are primarily designed for use within the MINI dealership organization and by authorized MINI service companies.

In any event, the target group for these installation instructions is specialist personnel trained on MINI cars with the appropriate specialist knowledge.

All work must be completed using the latest MINI repair manuals, circuit diagrams, servicing manuals and work instructions, in a rational order, using the prescribed tools (special tools) and observing current health and safety regulations.

To avoid unnecessary extra work and/or costs, if any installation or function problem occurs, after a brief troubleshooting session (approx. 0.5 hours), please contact the following:

- 1. Either your national subsidiary or your regional office, or**
- 2. The Support team via the Aftersales Assistance Portal (ASAP), using the optional technical parts support application.**

Specify the chassis number and the part number of the installed retrofit kit and give a precise description of the problem.

Do not archive the hard copy of these installation instructions since daily updates are made by ASAP!

Pictograms:



Denotes instructions that draw your attention to dangers.



Denotes instructions that draw your attention to special features.

◀ Denotes the end of the instruction or other text.

Subject to technical modifications.

Ensure that the cables/lines are not kinked or damaged as you install them in the car.
Costs incurred as a result of this will not be reimbursed by BMW AG.

Additional cables/lines that you install must be secured with cable ties.

The retrofit kit and installation instructions apply to left-hand drive vehicles only.

If the specified PIN chambers are occupied, bridges, double crimps or twin-lead terminals must be used.

Installation information

The retrofit kit may not be installed in vehicles with diesel engines.

For vehicles with the combination of xenon lights (option 522) and high pressure washing system (option 502), the gas pressure hood dampers (part No. 51 23 7 064 485) must be replaced for safety reasons.

Ordering information:

The optional switch **S** can be installed in the center console instead of in the instrument panel.

The additional cable **Y** is required for this purpose (Part No. 61 12 0 412 968). On vehicles before 07/2004 the center console must also be replaced (handbrake console, panther black, Part. No. 51 16 6 958 571).

Special tools required

None

Contents

Section	Page
1. Parts overview	4
2. Preparatory work	6
3. Installation and cabling diagram	7
4. Connections diagram.	8
5. Installing the mounting brackets	10
6. Installing the switch.	13
7. Routing the cable loom.	14
8. Optional: Installing switch in center console	17
9. Installing the fuse – for retrofit kits with fuse box	18
10. Installing the fuse – for retrofit kits with in-line fuse	20
11. Attaching and adjusting headlights	21
12. Installing the auxiliary high-beam headlight support – three-bar and four-bar grill.	23
13. Installing the auxiliary high-beam headlight support – aerodynamics package grill	25
14. Concluding work and coding	26
15. Circuit diagram	27
16. Instruction sheet for MINI auxiliary high-beam headlights	29

1. Parts overview

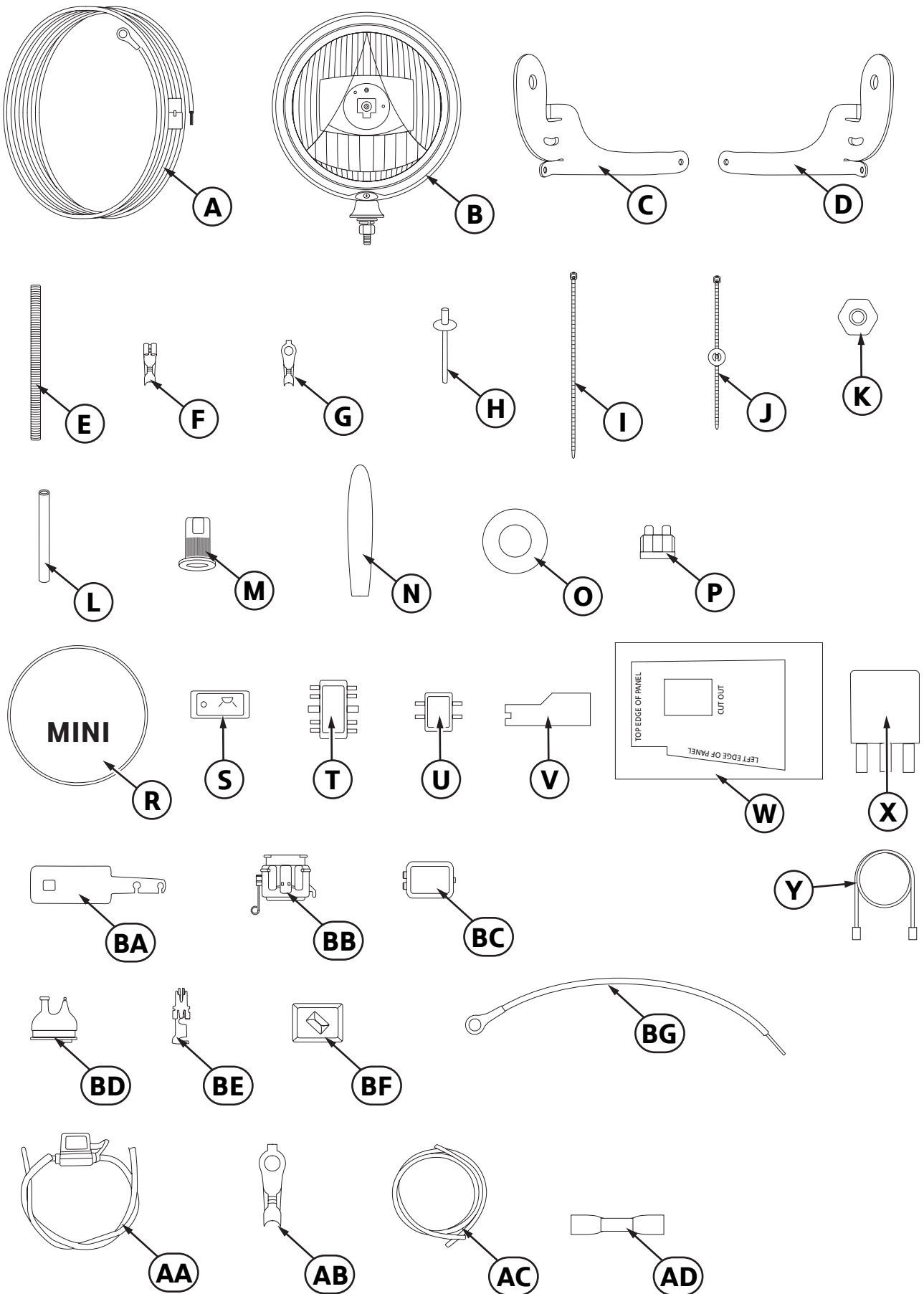

050 0921 V

Key

- A Headlight wiring harness
- B Auxiliary high-beam headlights (2 pcs.)
- C Right mounting bracket
- D Left mounting bracket
- E Retaining pin with slot M4 (2 pcs.)
- F Flat connector bushing (2 pcs.)
- G Ring cable shoe (2 pcs.)
- H Rivet (6 pcs.)
- I Cable ties (10 pcs.)
- J Engine hood cable ties (5 pcs.)
- K Hexagon nut M4 (2 pcs.)
- L Shrink-fit hose (2 pcs.)
- M Blind-rivet nut M4 (2 pcs.)
- N Immersion cap (2 pcs.)
- O Plastic disc (2 pcs.)
- P Fuse 15 A
- Q not applicable
- R Headlight cover (2 pcs.)
- S Switch
- T Mini-connector, 5 contacts
- U Mini-connector, 2 contacts (2 pcs.)
- V Connector (2 pcs.)
- W Template
- X Electronics module
- Y Optional: Additional cable for switch

Only for retrofit kits with in-line fuse

- AA In-line fuse
- AB Ring cable shoe M8
- AC PVC protective sleeve
- AD Butt connector 2.5 mm²

Only for retrofit kits with fuse box

- BA Fuse box mounting bracket
- BB Fuse box
- BC Fuse box cover
- BD Fuse box rubber grommet
- BE Fuse box flat connector bushing 2.5 mm² and 4.0 mm² (2 pcs.)
- BF Fuse box fastening clip
- BG Fuse box cable loom

2. Preparatory work

	TIS No.
Perform quick test	---
Disconnect negative terminal of battery	12 00 ...
Remove the following components in advance:	
Front right entry cover strip	51 47 000
Sound insulation of the engine hood	51 48 001
Radio receiver	65 11 030
Storage compartment in instrument panel (driver's side)	51 16 392
Optional: For installing switch in center console	
Front center console	51 16 200
Rear center console	51 16 216

3. Installation and cabling diagram

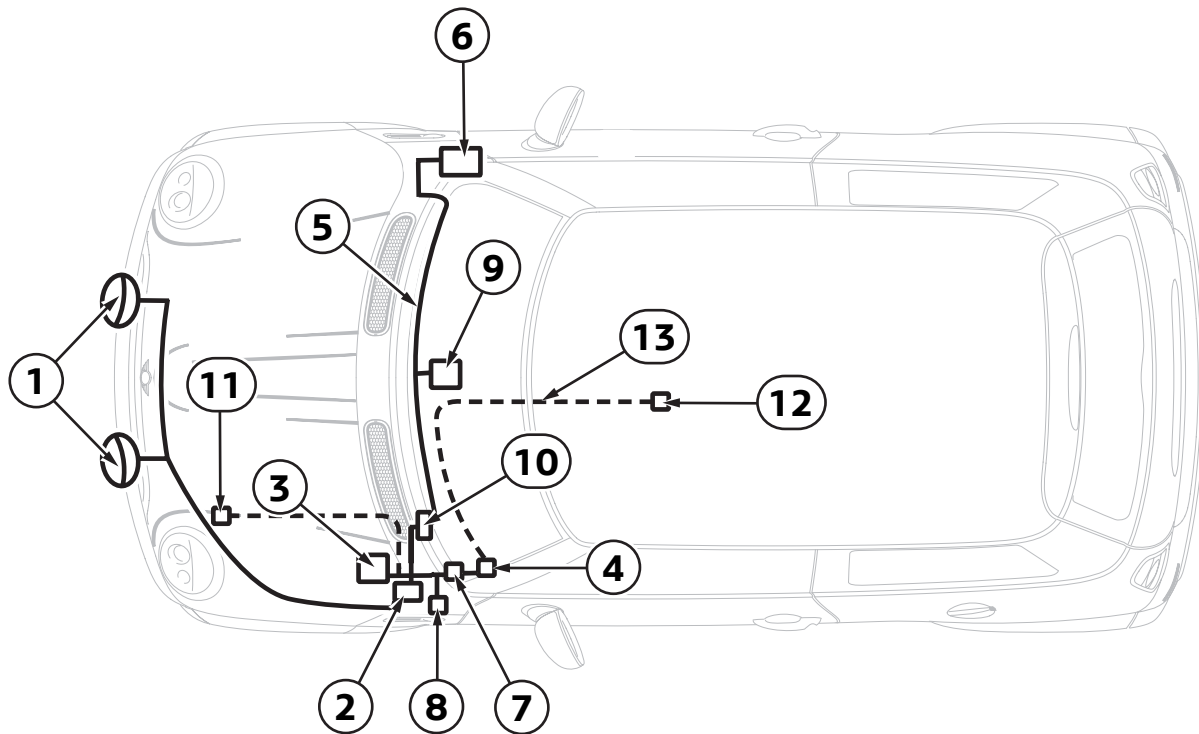

050 0922 V

Key

- 1 Auxiliary high-beam headlights
- 2 Fuse box/in-line fuse
- 3 Fuse box (vehicle)
- 4 Switch in instrument panel
- 5 Cable routing path in interior of vehicle
- 6 General module (BC1)
- 7 Electronics module
- 8 Ground bolt (only for vehicles up to 07/2004)
- 9 Main radio plug
- 10 Grommet
- 11 Ground bolt X175 (only for vehicles from 7/2004)

Optional:

- 12 Switch in center console
- 13 Additional cable for switch

4. Connections diagram

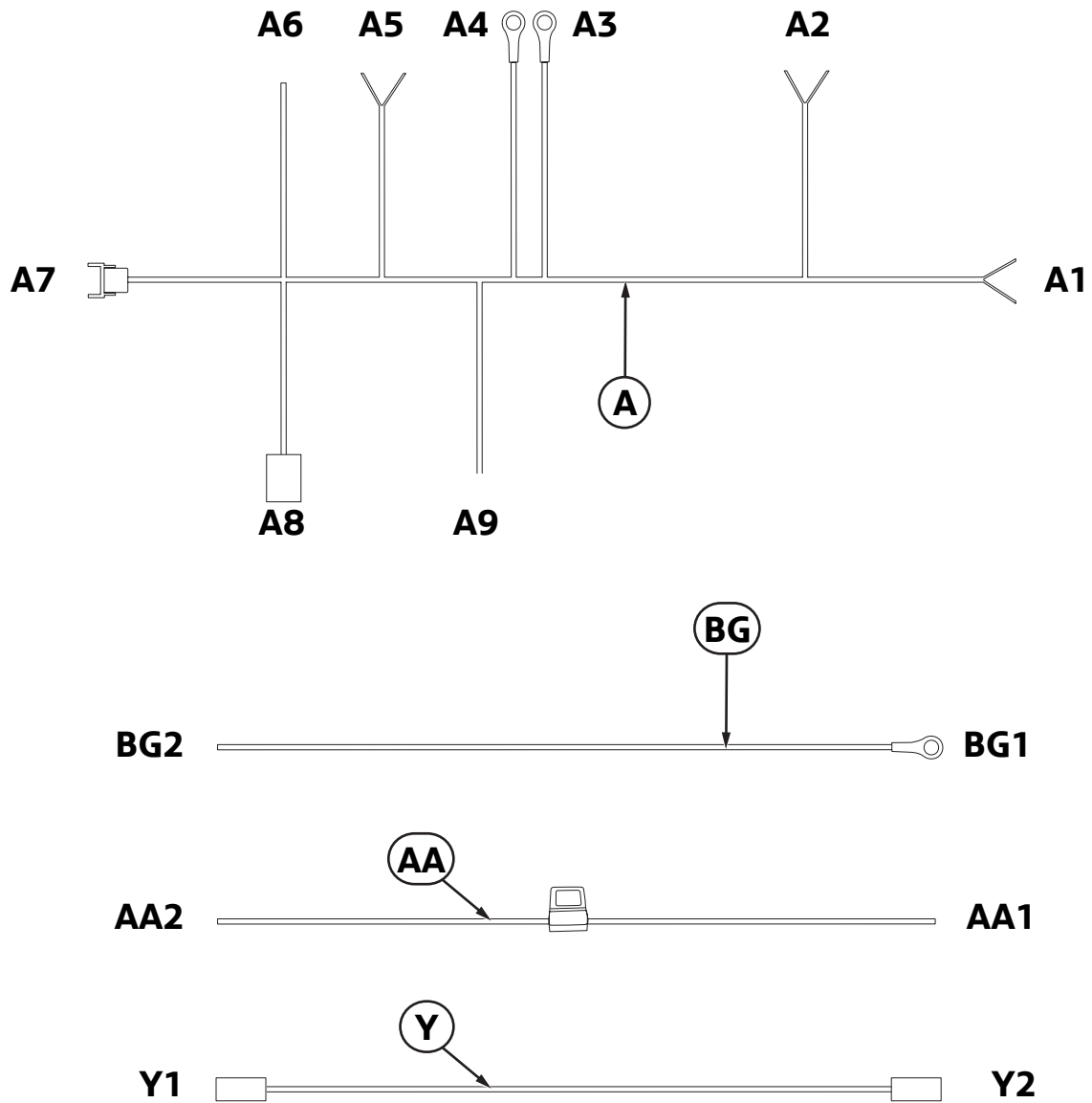

050 0978 V

Item	Designation	Signal	Cable colors/ cross-section	Connection location in vehicle	Short name/slot
A	Headlight wiring harness	---	---	---	---
A1	Open line	---	RD/BR BR	Right headlight	X004 X005
A2	Open line	---	RD/BR/YE BR	Left headlight	X002 X003
A3	Ring cable shoe	Kl. 31	BR	Ground bolt	X151/X175
A4	Ring cable shoe	Kl. 31	BR	Ground bolt	X151/X175
A5	Open line	---	GR/RD VI/BL	Main radio plug	---

4. Connections diagram

Item	Designation	Signal	Cable colors/ cross-section	Connection location in vehicle	Short name/slot
A	Headlight wiring harness	---	---	---	---
A6	Open line	---	YE/GN	BC 1, green plug	X332 PIN15
A7	Socket	---	GN BL BR RT RT YE/GN VI/BL	Driver's footwell area	---
A8	Connector	---	GN BL BR GR/RD	Auxiliary high-beam headlight switch	---
A9	Open line	---	RT	Fuse box	---
Only for retrofit kits with in-line fuse					
AA	In-line fuse cable loom	---	---	---	---
AA1	Ring cable shoe	Kl. 30	RT	Vehicle fuse box	X10
AA2	Open contact	Kl. 30	RT	Fuse box	X1
Only for retrofit kits with fuse box					
BG	Fuse box cable loom	---	---	---	---
BG1	Ring cable shoe	Kl. 30	RT	Vehicle fuse box	X10
BG2	Open contact	Kl. 30	RT	Fuse box	X1
Optional for switch installation in center console					
Y	Additional cable for switch	---	---	---	---
Y1	Connector	---	---	Branch A8 from headlight wiring harness	---
Y2	Connector	---	---	Auxiliary high-beam headlight switch	---

5. Installing the mounting brackets

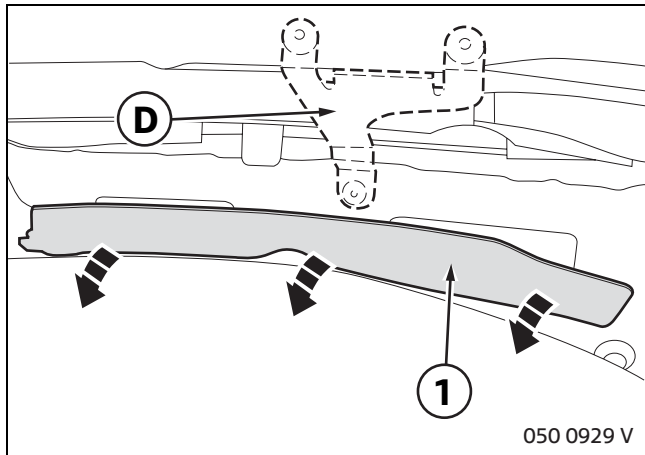

For vehicles from 09/2004:

Before installing mounting brackets **C** and **D**, remove the plastic covers (1) on the inside of the engine hood.

5. Installing the mounting brackets

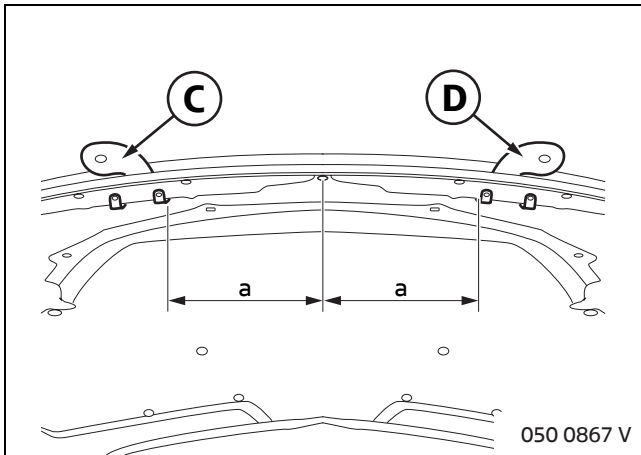

For all vehicles

Insert mounting brackets **C** and **D** through the grill (bottom bar) and align clearance accordingly so that it is centered.

$a = 192.5 \text{ mm}$

With the help of mounting brackets **C** and **D**, mark the bores for **H**, punch mark them and drill them (bore diameter 4.2 mm).

 Ensure that there is no gap between the mounting brackets and the inner plate of the engine hood.

To keep chips out, cover the engine compartment before drilling.

When drilling the bottom bores, also drill through the grill.

When drilling the top bores, make sure that the body shell is not damaged.

Remove burrs from all bores and treat them with the usual corrosion protection measures for MINI. ◀

Only for vehicles with sport package

 When the sport package is installed, the cutouts for feeding through the mounting brackets **C** and **D** must be made in advance. The position and size of the cutouts are marked on the rear of the grill.

Likewise, the blind-rivet nuts **M** of the auxiliary high-beam headlights (see Chapter 13) must be installed in advance. To do so, the grill must be removed.

Carefully make the cutouts using a suitable tool (saw). ◀

Only for vehicles with the xenon lights option and high pressure washing system (option 502)

For safety reasons, the gas pressure hood dampers (BMW part No. 51 23 7 064 485) must be replaced.

 Carefully make the cutouts using a suitable tool (saw). ◀

5. Installing the mounting brackets

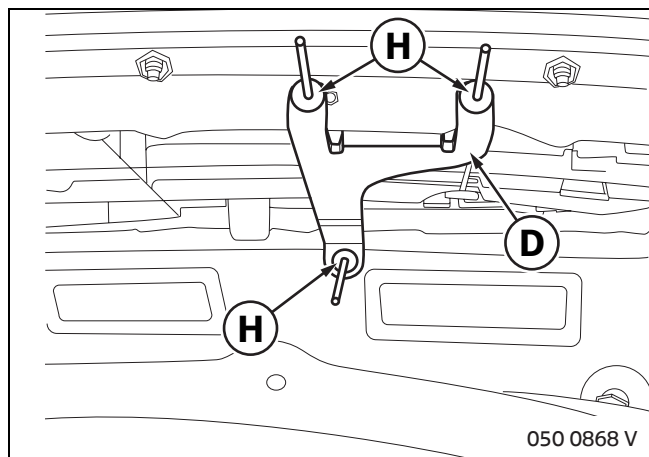

Insert mounting brackets **C** and **D** and secure them using rivet **H**. Tighten rivet **H** using a hand riveter.

▶ When riveting in the bottom rivet **H**, lift the grill so that the rivet head is free (do not rivet in the grill at the same time). ◀

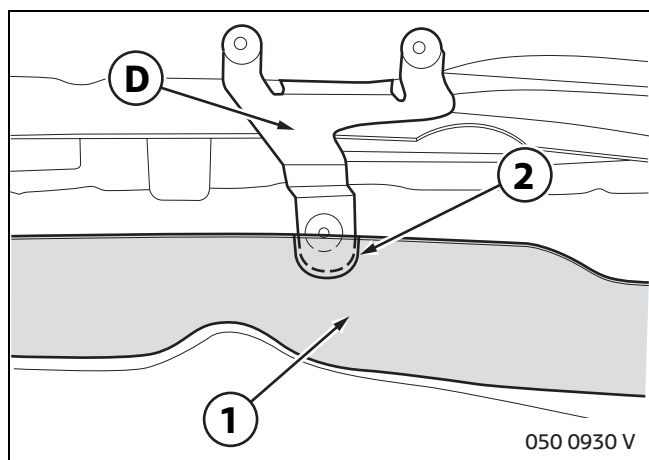

For vehicles from 09/2004:

Place the plastic cover (1) in its installation position next to the mounting bracket **D**. Draw on the mark (2) for the cutout.

Make the cutout using a suitable tool and reinstall the plastic cover (1).

6. Installing the switch

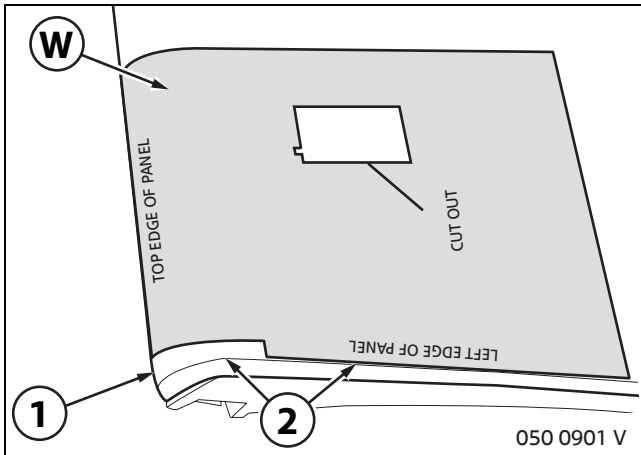

▶ The switch can be installed in the center console as an option, refer to Chapter 8. In this case the cutout in the knee bolster panel need not be produced.

To create the cutout for the switch **S** in the knee bolster panel, use the template **W**. ◀

Cut out the template **W** from the side (template number 01 29 0 147 414). Cut out the area marked "CUT OUT" on the template **W**.

Align the template **W** to the knee bolster panel (1) as shown. Lay the edge marked TOP EDGE OF PANEL along the top edge of the knee bolster panel (1). Lay the edge marked LEFT EDGE OF PANEL along the radius (2) on the left side of the knee bolster panel (1).

Mark the CUT OUT and remove the template **W**.

Carefully make the cutout using a suitable tool (air saw). Using a file, finish the cutout until the switch **S** is seated exactly in it.

▶ Make sure that the springs of the switch **S** are behind the edge of the cutout. If necessary, chamfer the places where the springs have not engaged. ◀

7. Routing the cable loom

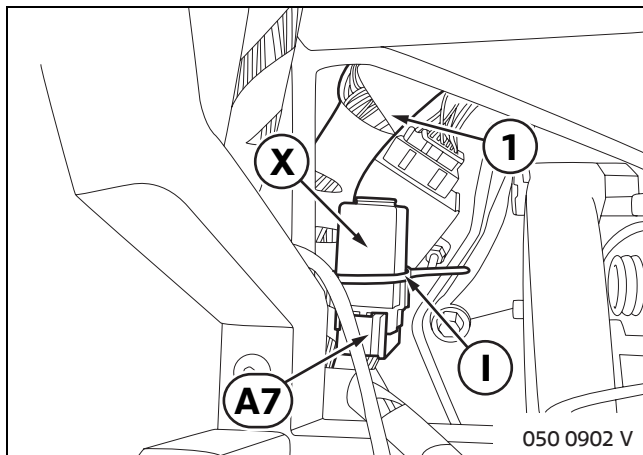

Plug the electronics module **X** into the socket at branch **A7**. Using cable tie **I**, fasten the electronics module **X** so that it is parallel to the existing cable tie (1) in the driver's footwell area.

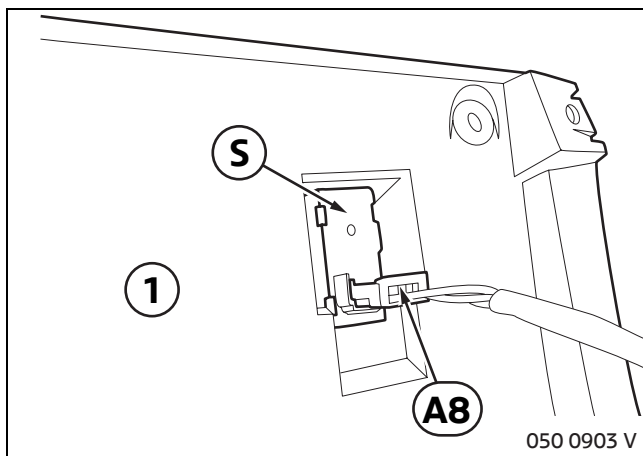

▣ The illustration shows the cutout in the knee bolster panel (1) from the rear. ◀

Snap the switch **S** into the cutout in the knee bolster panel. Connect branch **A8** to the switch **S**.

▣ The switch can be installed in the center console as an option (refer to Chapter 8). For this purpose, the additional cable for the switch **Y** on the branch **A8** must be connected to the branch **Y1** at this point. ◀

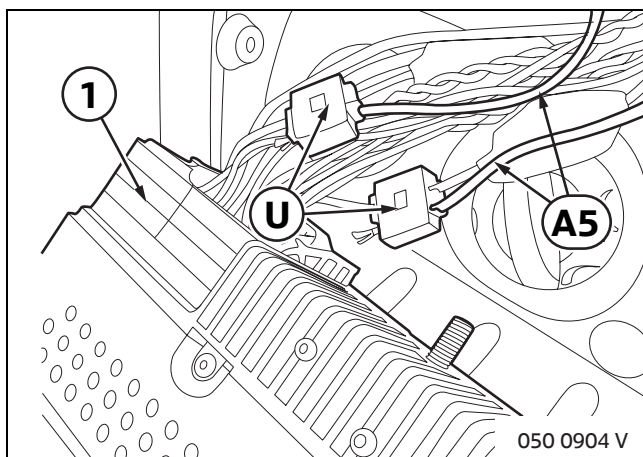

Route branch **A5** to the main radio plug (1). Using the 2x mini-connector **U**, connect the GR/RT and VI/BL cables to the identically colored cables of the same color of the main radio plug (1).

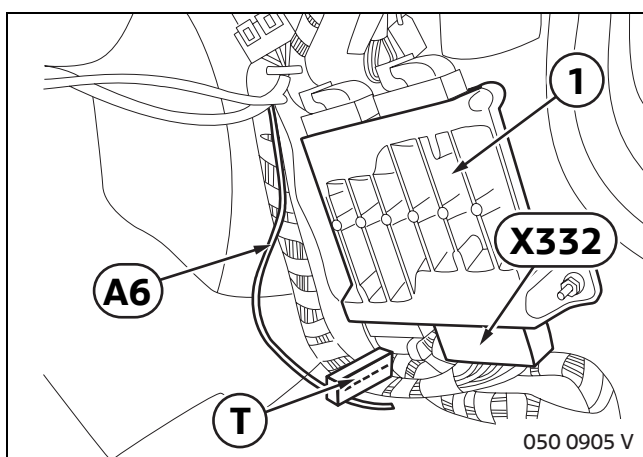

Unplug the green plug **X332** from General Module **BC1** (1).

Using the 5x mini-connector **T**, connect branch **A6** to the cable pinned into PIN 15.

7. Routing the cable loom

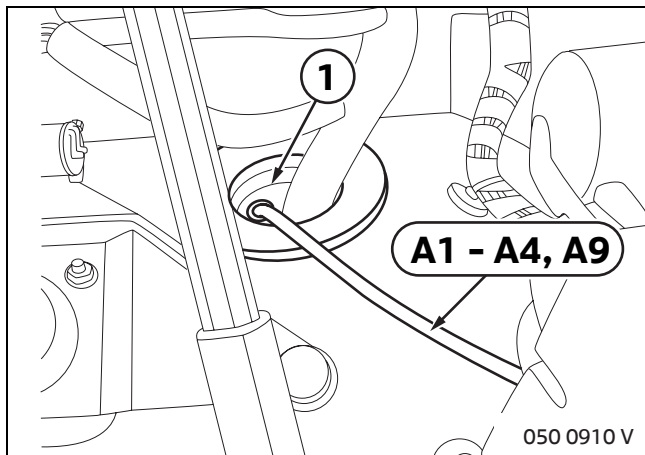

Route branches **A1-A4** and **A9** into the engine compartment through the bore you have drilled in the passage grommet (1).

The passage grommet (1) is located next to the passage to the brake booster (refer to illustration 050 0842 V in the installation diagram). The brake booster is always on the driver's side.

☐ Ensure that the cables are laid neatly (fasten cable loom **A** in place using cable ties).

Seal the hole in the passage grommet (1) using a suitable sealant (such as Sikaflex). ◀

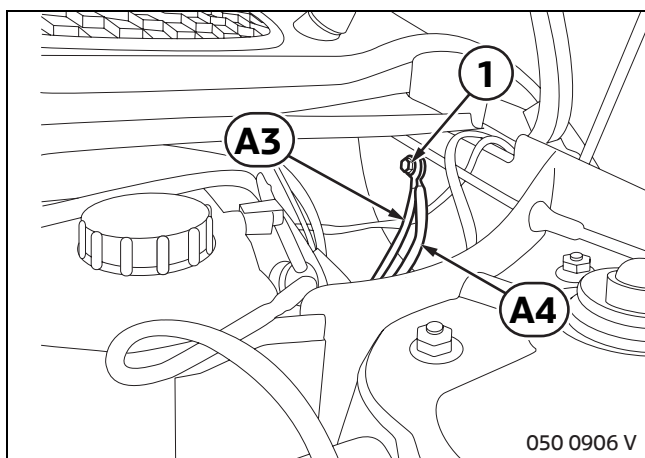

For vehicles until 07/2004:

Route branches **A3** and **A4** from cable loom **A** to the ground bolt (1) close to the shutoff valve and connect them.

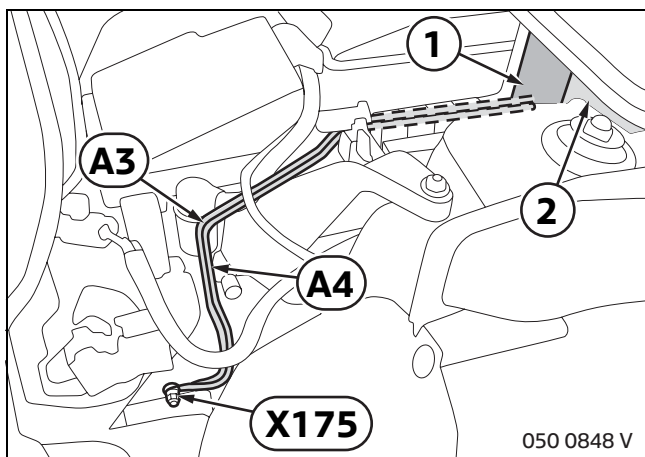

For vehicles from 07/2004:

Create the passages for branches **A3** and **A4** in the partition (1) of the fire wall (2).

Route branches **A3** and **A4** to the ground bolt **X175** and connect them.

☐ It is possible for the ground bolt **X175** to be located on the inside of the engine carrier. ◀

7. Routing the cable loom

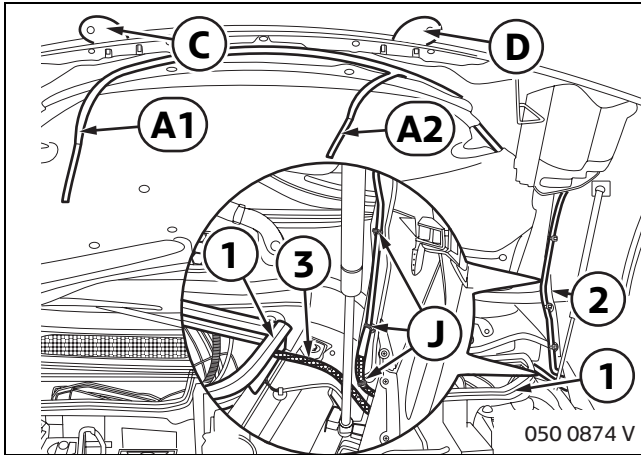

For all vehicles

Guide branches **A1** and **A2** out underneath the rubber seal (1) and along the engine hood bracket (2) with the help of the engine hood cable tie **J** (see enlarged area) to the mounting brackets **C** and **D**.

Ensure that the fabric hose (3) is routed into the side panel area in the form of a loop.

 For vehicles with high pressure washing system, the engine hood cable ties **J** are already present. ◀

In that case, route branches **A1** and **A2** parallel to the high-pressure hose using the cable ties **I**.

Guide branches **A1** and **A2** out through the longitudinal cutouts (1) in mounting brackets **C** and **D** and secure them using cable guides **I**.

Only for vehicles with sport package

When the sport package is installed, branches **A1** and **A2** are not to be guided out through the longitudinal cutouts (1) in the mounting brackets. Rather, they are to be guided directly underneath the mounting brackets (2) (see dotted line) through the grill.

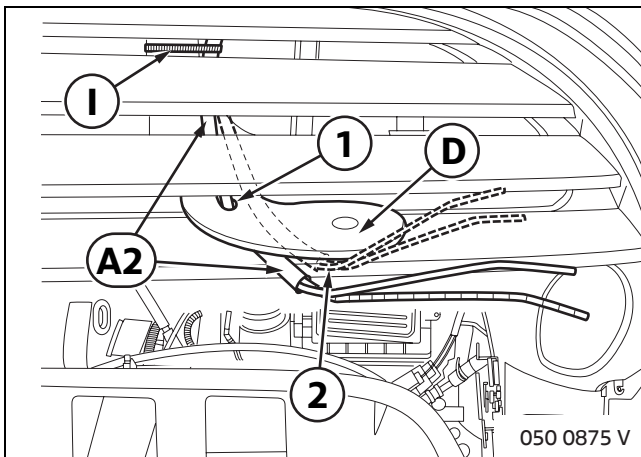

8. Optional: Installing switch in center console

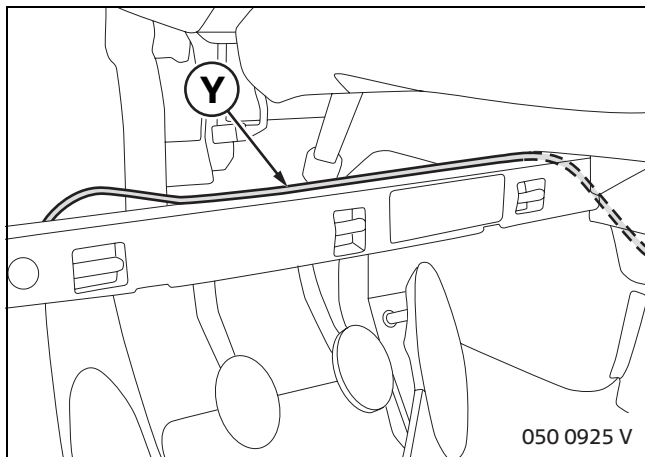

 The switch can be installed in the center console instead of in the instrument panel as an option. For this purpose, the center console is removed according to TIS No. 51 16 216.

On vehicles before 07/2004 the center console must be replaced (refer to Ordering Instructions, Page 2, TIS No. 51 16 217).

Route the additional cable for the switch **Y** along the instrument panel to the center console.

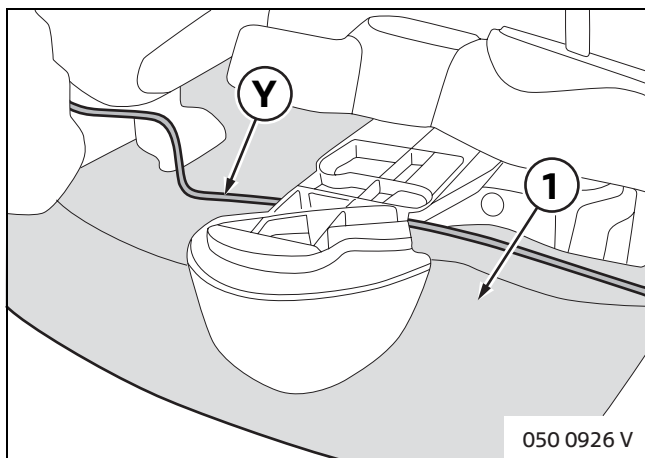

Route the additional cable for the switch **Y** along the drive shaft tunnel (1) to the handbrake.

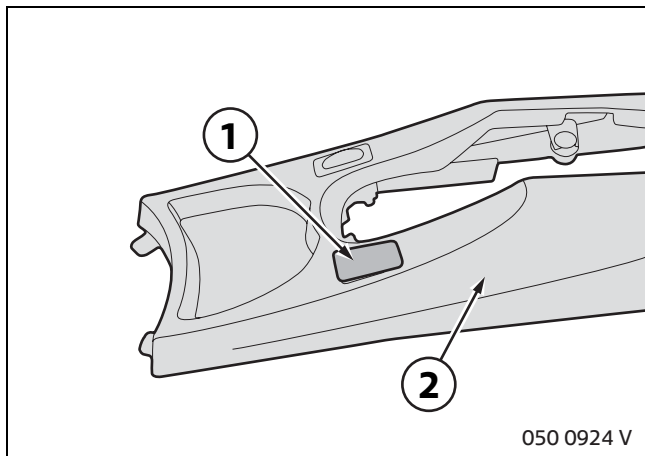

Remove the cover (1) from the center console (2).

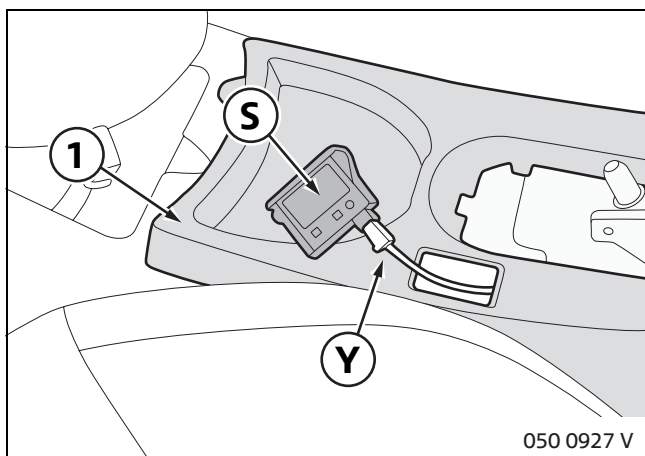

Connect the switch **S** to the additional cable for the switch **Y**. Install the switch **S** in the center console.

Install the center console again according to TIS No. 51 16 216.

9. Installing the fuse – for retrofit kits with fuse box

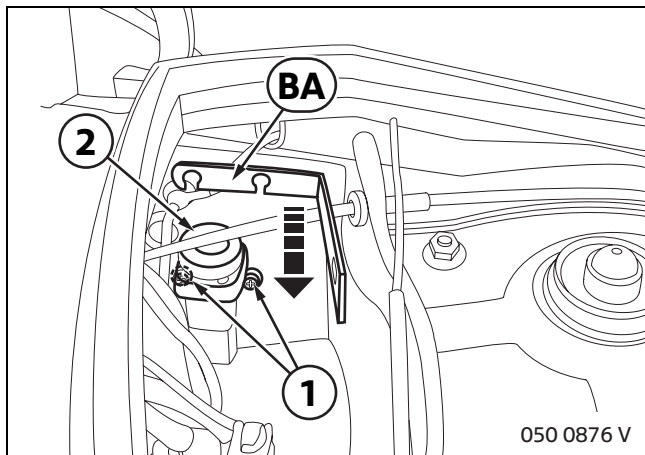

For vehicles until 09/2002:

Slightly unscrew the screws (1) of the shutoff valve (2).

Insert holder **BA** behind shutoff valve (2) and retighten the screws (1).

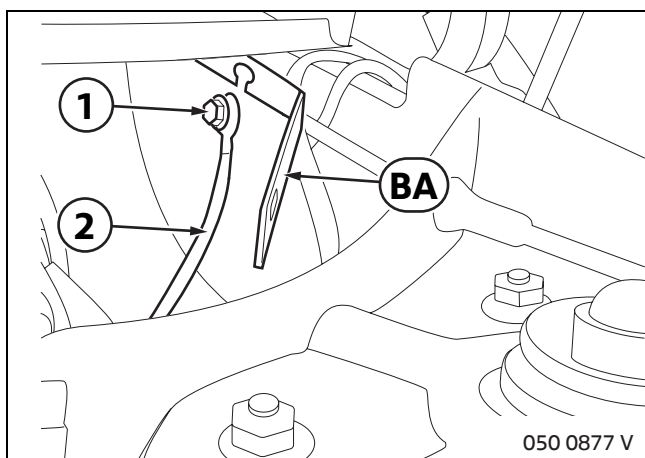

For vehicles from 10/2002 to 06/2004

Unscrew the nut (1) of the ground bolt. Attach mounting bracket **BA** onto the ground bolt and tighten the nut (1).

Tightening torque: 8 Nm.

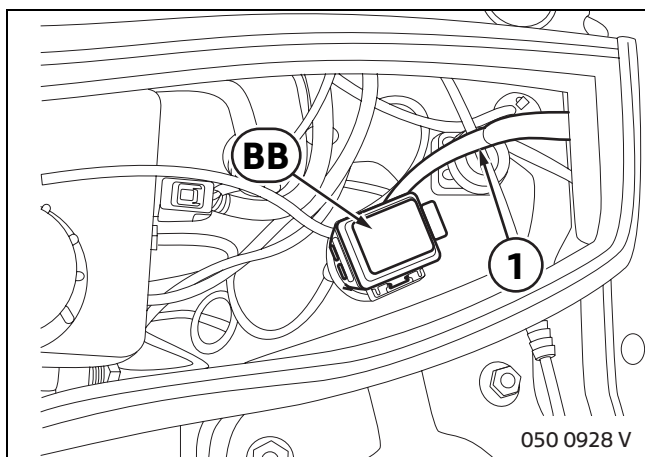

For vehicles from 07/2004:

Secure the fuse box **BB** with a cable tie **I** on the existing wiring harness (1).

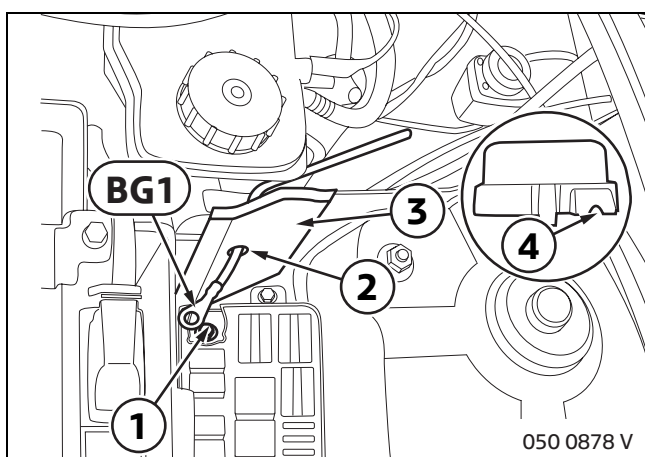

For all vehicles with fuse box:

At the height of the B+ connection (1) in the vehicle fuse box, drill a bore (2) (\varnothing 6 mm) into the plastic trim piece (3) and remove the burrs.

Connect branch **BG1** and pull it through the plastic trim piece (3).

 If necessary, trim the plastic cover of the vehicle fuse box (4) slightly so that it can be closed. ◀

9. Installing the fuse – for retrofit kits with fuse box

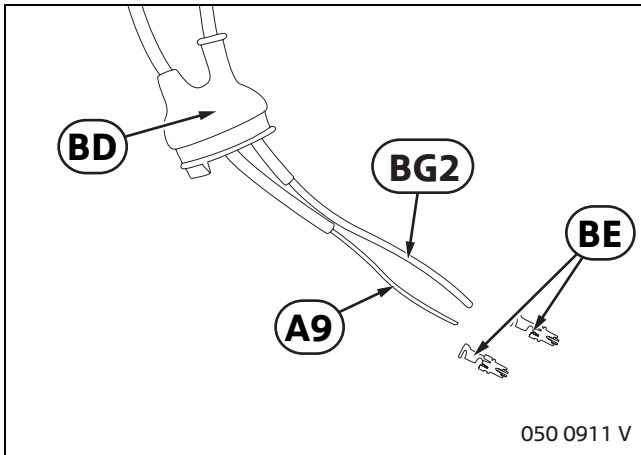

Trim the fuse box rubber grommet **BD** and feed in branches **A9** and **BG2**.

▣ The flat connector bushings **BE** have different sizes (2.5 mm² and 4.0 mm²) and must be assigned to the wires. ◀

Shorten branches **A9** and **BG2** and crimp the flat connector bushings **BE**.

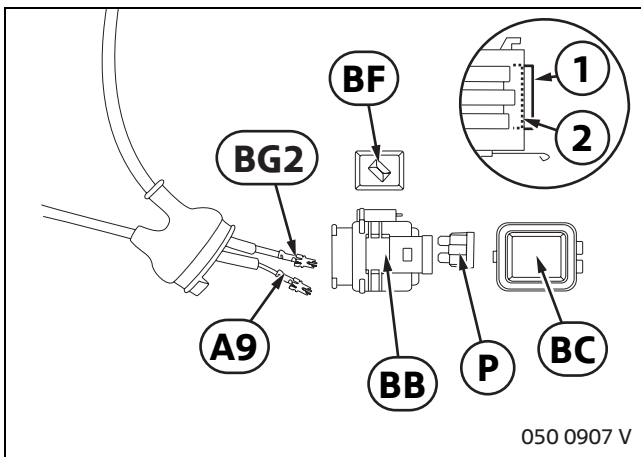

Insert the branches **A9** and **BG2** into the fuse box **BB**. Insert the fuse **P** into the fuse box **BB** and attach the fuse box cover **BC**.

Fasten the fastening clips for the fuse box **BF** to the fuse box **BB**.

Once the cable is all the way in the fuse box **BB**, the fuse box **BB** must be moved from the unlocked (1) into the locked position (2) (dotted line in the enlarged area).

It must click audibly when moved.

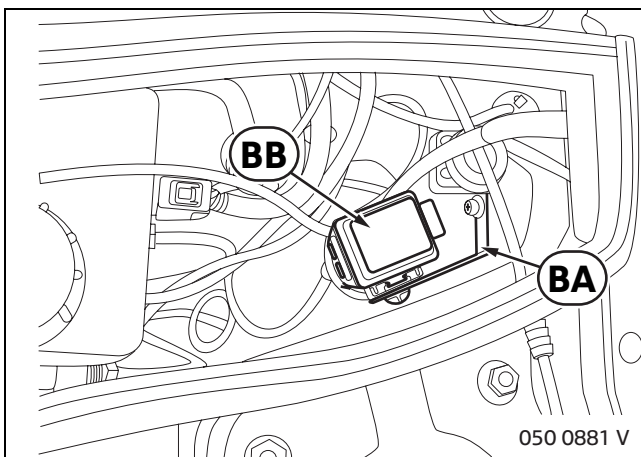

Using a rotation movement, insert fuse box **BB** into the fuse box mounting bracket **BA**.

10. Installing the fuse – for retrofit kits with in-line fuse

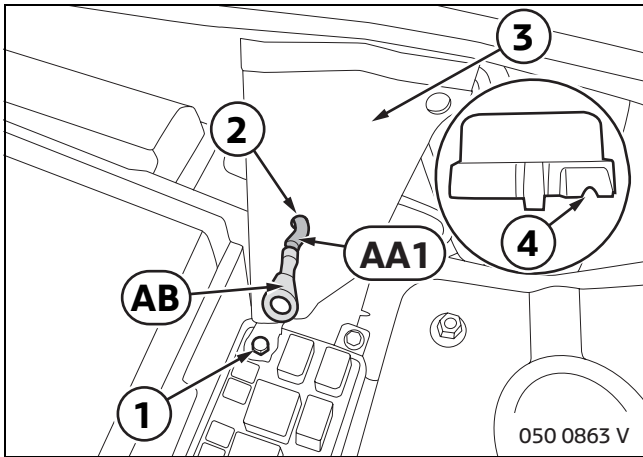

At the height of the B+ connection (1) in the vehicle fuse box, drill a bore (2) (\varnothing 5 mm) into the plastic trim piece (3) and remove the burrs.

Pull the PVC protective sleeve AC via branch AA1. Guide branch AA1 through the bore (2) and crimp on the ring cable shoe AB.

Connect branch AA1 to the B+ connection (1).

 If necessary, trim the plastic cover of the vehicle fuse box (4) slightly so that it can be closed. ◀

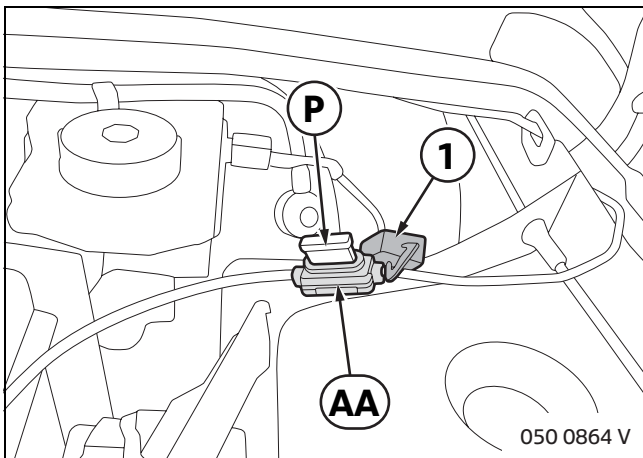

Insert the fuse P into the in-line fuse AA and close the cover (1).

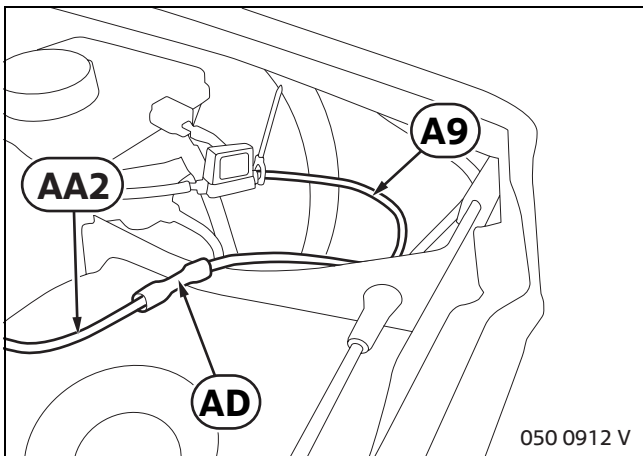

Using butt connector AD, connect branch A9 and AA2 as follows:

- Connect branch A9 and AA2 to the butt connector using a suitable crimping tool.
- Using a hot-air gun, shrink the transparent insulation of the butt connector and heat it until the liquid glue inside it has melted in order to seal the connection.

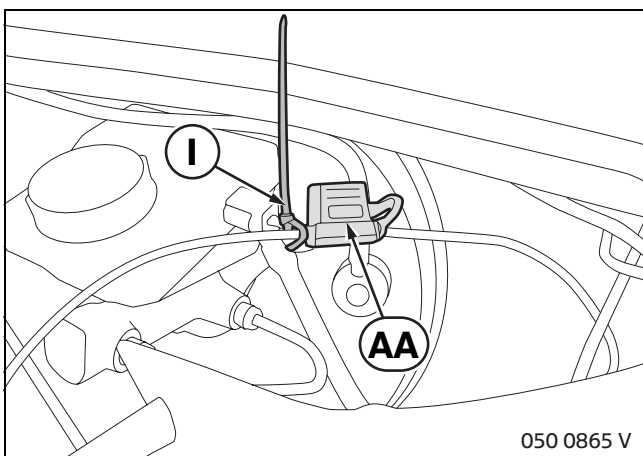

Fasten the in-line fuse AA to the existing wiring harness using the cable tie I.

 Use cable ties I to tie back any excess lengths. ◀

11. Attaching and adjusting headlights

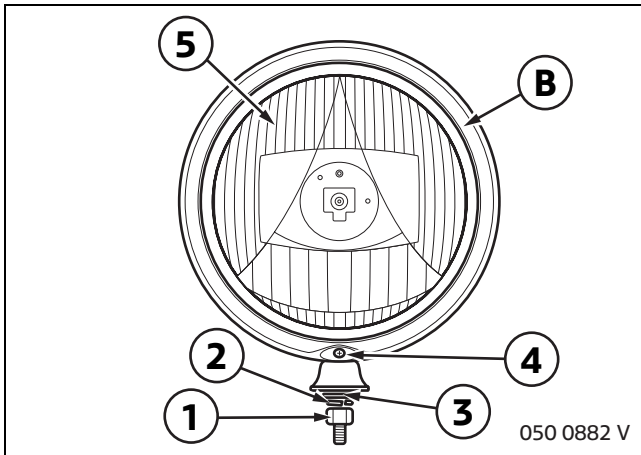

Screw off the nut (1), retainer (2) and washer (3) from the headlight **B**.

Unscrew the Phillips screw (4) and take off the reflector unit (5).

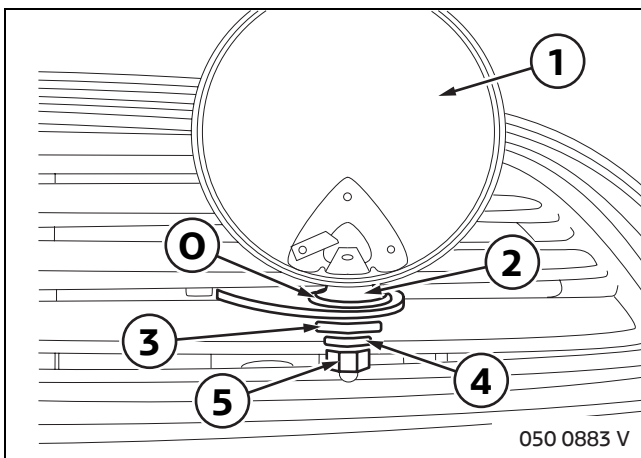

Attach each headlight housing (1) along with the headlight foot (2) and attached plastic disc **O** to mounting brackets **C** and **D** and gently screw it into place from below using the washer (3), retainer (4) and nut (5).

▶ Align the plastic disc **O** concentrically to the headlight foot. ◀

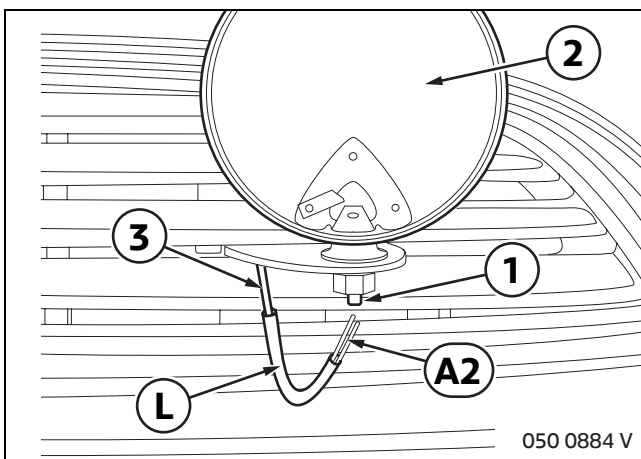

Pull the shrink-fit hose **L** through branch **A1** or **A2** and allow it to overlap slightly with the existing hose (3).

Using the hot-air gun, shrink the shrink-fit hose **L** and feed it into the headlight housing (2) through the hollow screw (1).

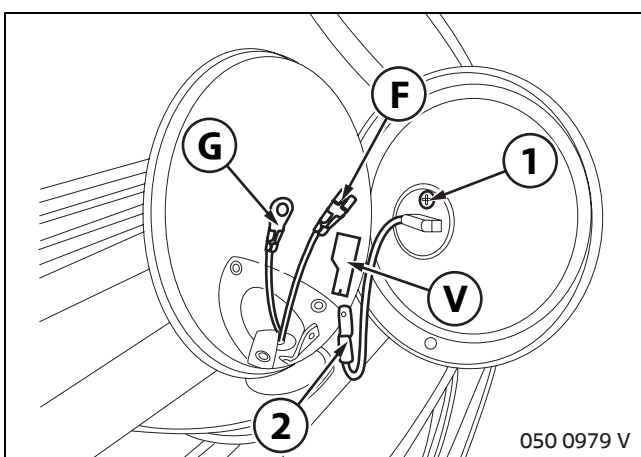

Crimp on branches **A1** and **A2** as follows:

- Cable RD/BR **A1** or RD/BR/YE **A2**: flat connector bushing **F**
- BR cable: Ring cable shoe **G**

Fasten ring cable shoe **G** to the bulb using the Phillips screw (1) and attach the flat connector bushing **F** to the bulb cable (2).

▶ Before connecting the bulb cable (2), attach connector **V** to the flat connector bushing **F**. After connecting the bulb cable (2), wrap insulation tape around the cable to prevent shorts. ◀

11. Attaching and adjusting headlights

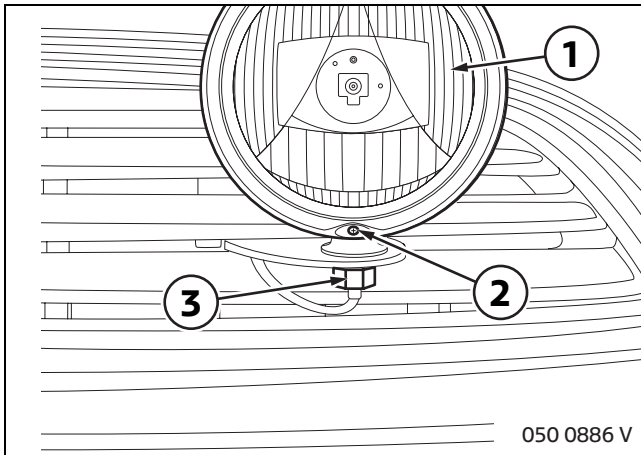

Insert the reflector unit (1) into the housing and tighten it using the Phillips screw (2).

Screw on the nut (3) hand-tight.

Adjusting using the headlight adjustment device

Adjust the lamps using the headlight adjustment device. Tighten the nuts (3).

Tightening torque: 9 Nm.

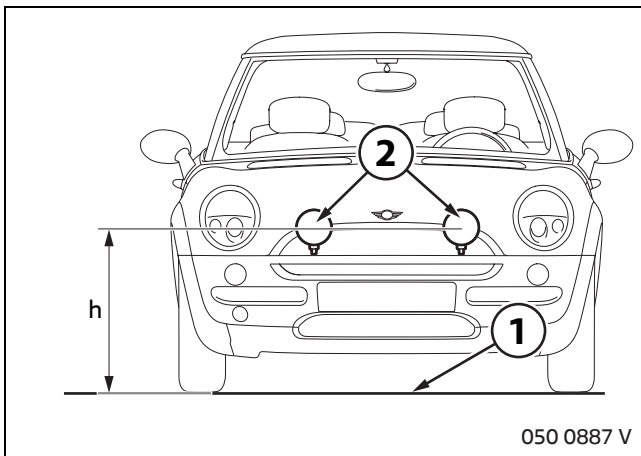

Adjusting without a headlight adjustment device

Place the unloaded vehicle on a level support surface (1). Measure the height h vertically from the support surface (1) to the center of the headlights (2).

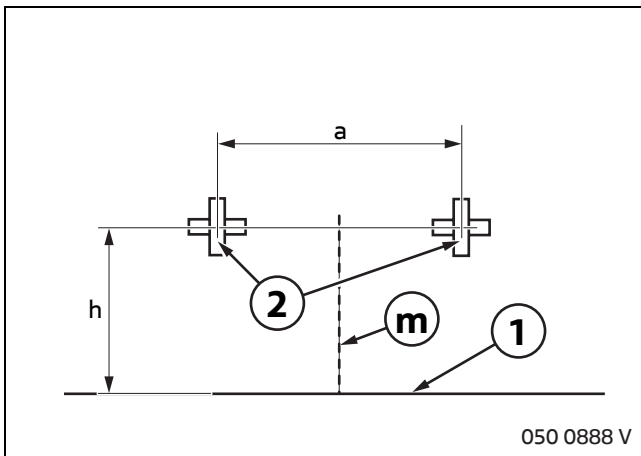

Draw a line parallel to the support surface (1) on a wall at height h . At a distance $a=540\text{ mm}$, make two marks (in the shape of plus signs) (2) on the line and mark the middle m between the two plus signs (2).

Position the vehicle at a distance of 3 to 5 m from the wall. Then, adjust the headlights so that the center of each beam meets the middle of the respective plus sign (2).

Tighten the nuts (3) (see illustration 050 0886 V).

Tightening torque: 9 Nm.

 Position the vehicle so that the extension of the longitudinal axis of the vehicle is perpendicular to the wall and meets the middle m between the marks (2) exactly. If possible, carry out the adjustment process in the dark. ◀

12. Installing the auxiliary high-beam headlight support – three-bar and four-bar grill

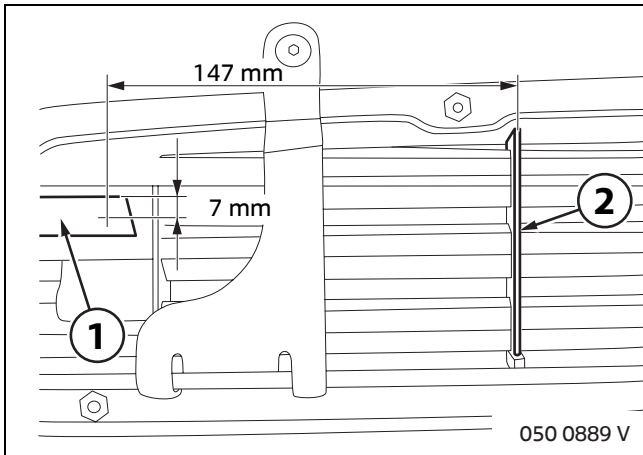

Only for vehicles with four-bar grill:

On surface (1), make a mark at a distance of 147 mm from the ridge (2).

Make a mark at a distance of 7 mm from the top edge of surface (1).

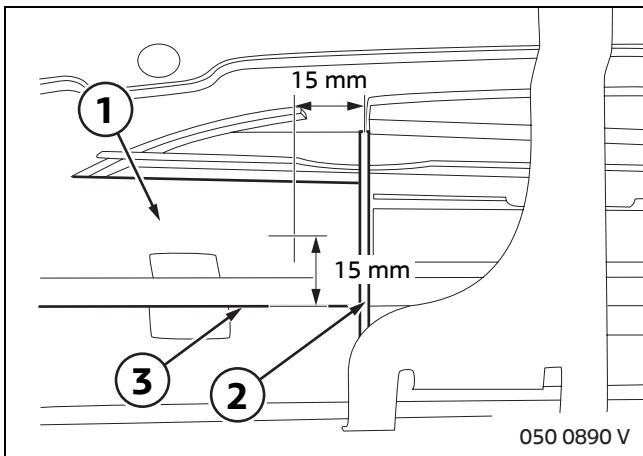

Only for vehicles with three-bar grill:

On surface (1), make a mark at a distance of 15 mm from the ridge (2).

Then make a mark at a distance of 15 mm from the ridge (3).

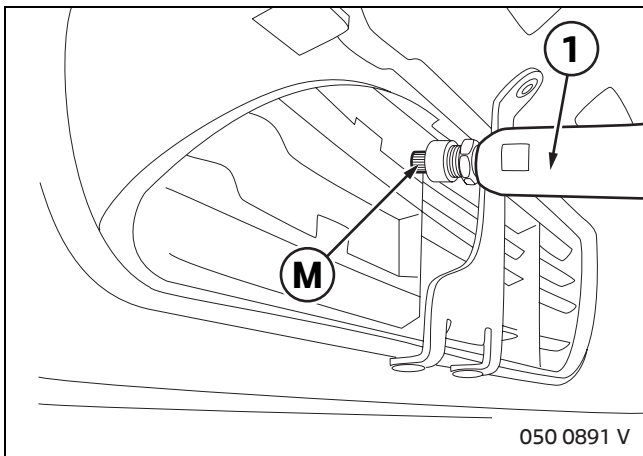

▶ Ensure that the drill does not stray off course to avoid damaging the bars.

To keep chips out, cover the engine compartment before drilling. ◀

Drill the bores for the blind-riev nuts **M** (pilot drill Ø 3 mm, drill Ø 6.1 mm).

Remove burrs from the bores and rivet in blind-riev nuts **M** from the inside of the grill using a blind rivet nut tool (1).

12. Installing the auxiliary high-beam headlight support – three-bar and four-bar grill

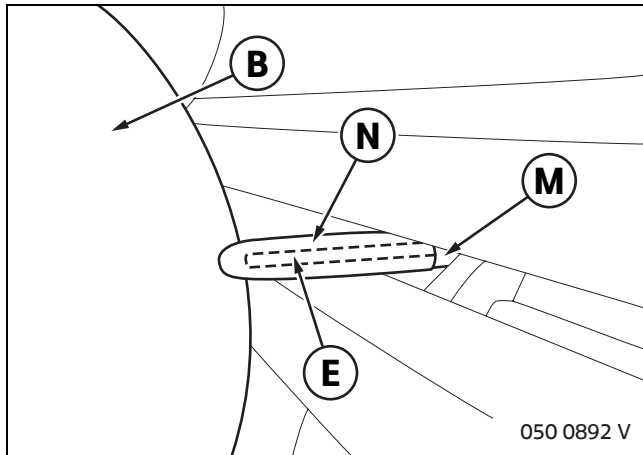

▶ For the combination of the continuously variable transmission (CVT) and the three-bar grill, shorten the protrusion of the retaining pin **E** behind the hexagon nut **K** to 5 mm. ◀

Shorten immersion cap **N** by repeatedly fitting it to the distance between blind-rivet nut **M** and headlight **B**.

Screw retaining pin **E** from the inside into blind rivet nut **M** far enough so that the immersion cap **N** can be attached. Unscrew retaining pin **E** until it touches the housing of the headlight **B**.

By turning it two revolutions, create the necessary pretension on headlight **B** and lock it against the collar of the blind rivet nut **M** using the hexagon nut **K**.

13. Installing the auxiliary high-beam headlight support – aerodynamics package grill

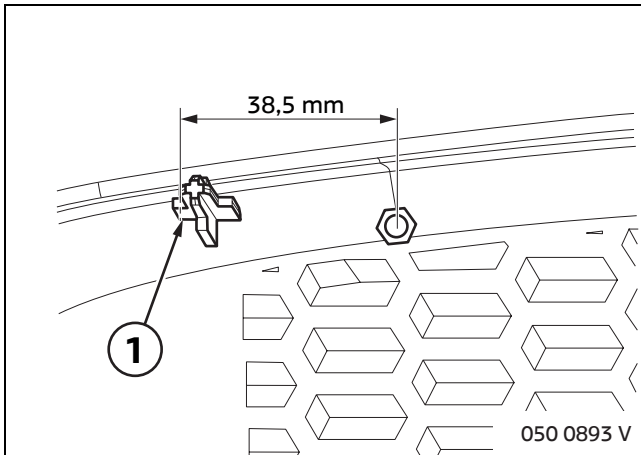

Make a mark at a distance of 38.5 mm from the outer edge of the pin (1) towards the center of the grill.

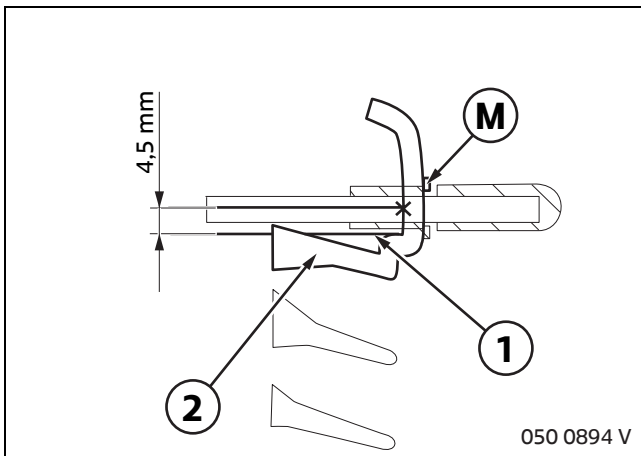

Then mark the dimension of 4.5 mm from the contour (1) of the grill (2).

Drill the bores for blind-rivet nuts **M** (pilot drill \varnothing 3 mm, drill \varnothing 6.1 mm). Remove burr from the bores and rivet in blind-rivet nuts **M** from the outside using the blind rivet nut tool.

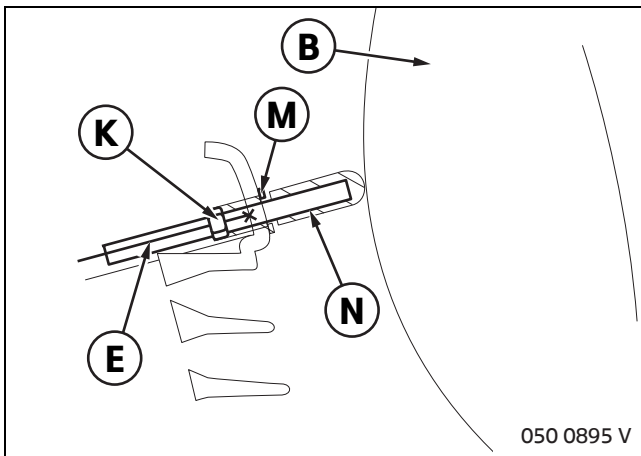

⚠ For the combination of the continuously variable transmission (CVT) and aerodynamics package grill, shorten the protrusion of the retaining pin **E** behind the hexagon nut **K** to 5 mm. ◀

Shorten immersion cap **N** by repeatedly fitting it to the distance between blind-rivet nut **M** and headlight **B**.

Screw retaining pin **E** from the inside into blind rivet nut **M** far enough so that the immersion cap **N** can be attached. Unscrew retaining pin **E** until it touches the housing of the headlight **B**.

With two revolutions, create the necessary pretension at headlamp **B**. Lock it against the blind-rivet nut **M** using the hexagonal nut **K**.

14. Concluding work and coding

The retrofit system does not require encoding.

- Reconnect battery
- Perform quick test
- Conduct operating test

Reassemble vehicle in reverse order.

15. Circuit diagram

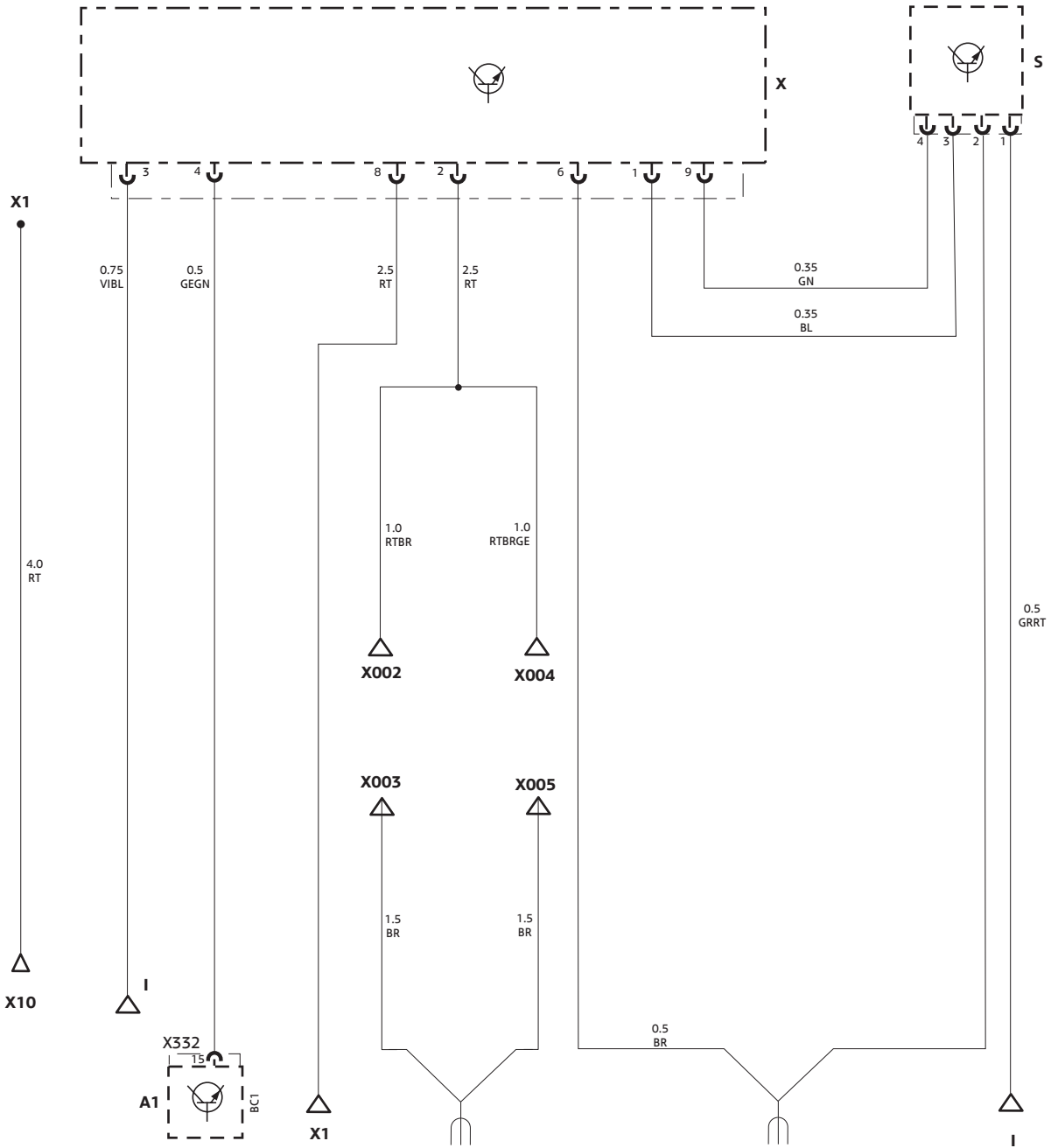

15. Circuit diagram

Key

A1	General module BC1
X	Electronics module with socket
X1*	KS 30 (fuse box)
X10*	KS 30 (vehicle fuse box)
X002*	Left headlight lead
X003*	Left headlight ground
X004*	Right headlight lead
X005*	Right headlight ground
	Ground bolt
X332	General module BC1, green plug
I	Main radio plug
S	Switch

All designations marked with * apply to these installation instructions or this circuit diagram only.

Cable colors

RT	Red
VI	Violet
BL	Blue
YE	Yellow
GN	Green
BR	Brown
GR	Gray

16. Instruction sheet for MINI auxiliary high-beam headlights

(To be provided to the customer, enclosed with the owner's manual.)

Changing the bulb

Lamps and lights are an essential component of vehicle safety. Therefore, use appropriate care when handling them. If you are not familiar with such work, have your MINI service shop do it for you.

 Do not touch the glass of new bulbs with your bare hands, as even slight amounts of dirt will become baked on and reduce the service life of the lamp. Use a clean cloth, a paper towel or the like, or hold the bulb by its base. ◀

 Whenever you work on the electrical system, switch off the affected consumers or disconnect the negative terminal of the battery, as otherwise short circuits may occur. Be absolutely certain to follow any instructions included by the bulb manufacturer in order to prevent injury and damage while changing bulbs. ◀

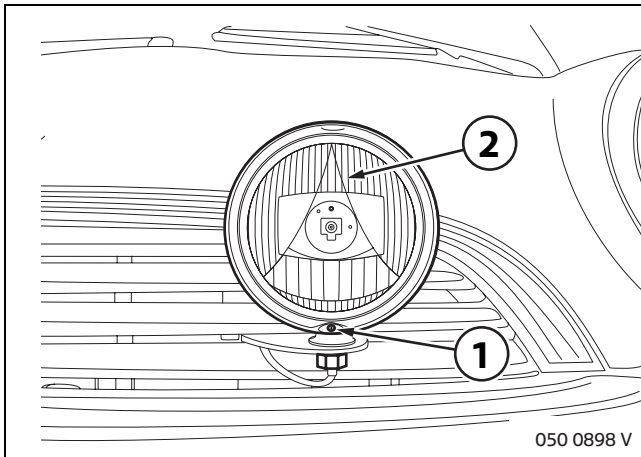

Unscrew the Phillips screw (1).

Remove the headlight insert (2) from the housing.

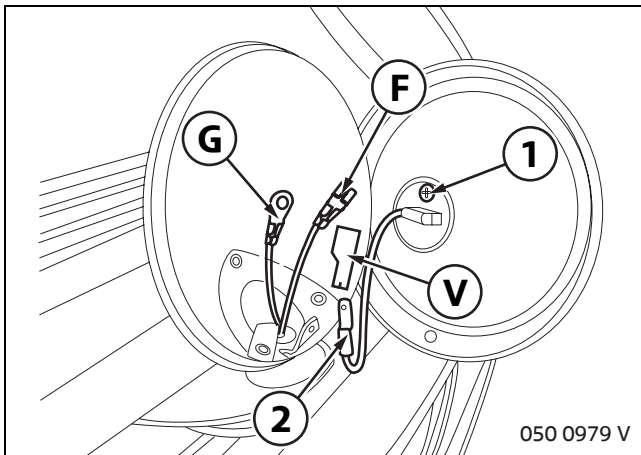

Remove the insulation from the connector (1). Carefully pull the lamp cable (2) out of the connector.

Release the screw connection (3).

Pull out the old bulb and insert the new one; use an H3 55-watt lamp.

Install it by following the above steps in reverse order.

 Replace the insulation tape at the location of the connector (1) and the lamp cable in order to avoid a short circuit.

16. Instruction sheet for MINI auxiliary high-beam headlights

Changing the fuse

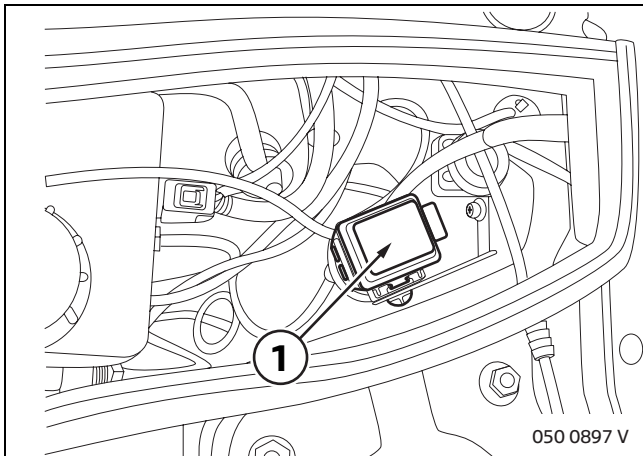

! Never repair a burned out fuse or replace it with a fuse of another color or amperage, as otherwise overloaded electric lines can cause a fire in the vehicle. ◀

For vehicles with fuse box:

The fuse box (1) is at the front left of the engine compartment. The fuse has an amperage of 15 A. Remove the cover of the fuse box. Change the fuse. Replace the cover. If fuses blow repeatedly, have the cause of the problem repaired by a MINI service location.

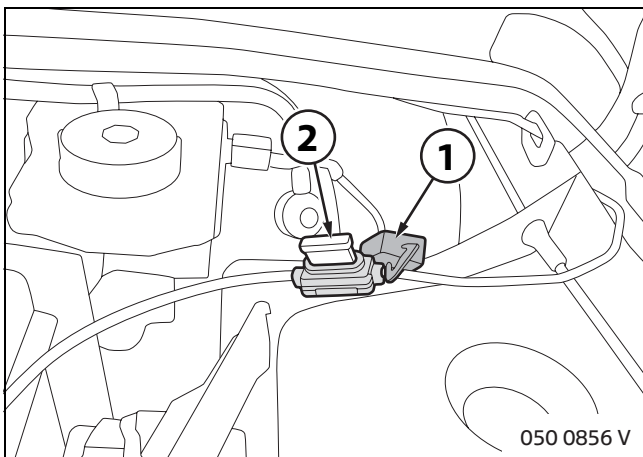

For vehicles with in-line fuse:

The in-line fuse is at the front left of the engine compartment. The fuse has an amperage of 15 A. Remove the cover (1) of the in-line fuse. Replace the fuse (2). Replace the cover (1). If fuses blow repeatedly, have the cause of the problem repaired by a MINI service location.

Care and cleaning

▶ Observe the following when caring for the auxiliary high-beam headlights:

Never dry rub them or use abrasive or corrosive cleaners.
Soften dirt (such as insects) using MINI shampoo and rinse with plenty of water.
Thaw ice using de-icer spray; do not use an ice scraper.

About four times a year, treat the auxiliary high-beam headlights with chrome care products commonly used for BMW Group vehicles.

You can wash your MINI, with the auxiliary high-beam headlights installed, in automatic car washes. Whenever possible, choose car washes with roller brushes. ◀

Operating the auxiliary high-beam headlights

Basic settings:

- Turn on the ignition.
- Switch on the switch in the knee driver's knee bolster panel (optional: center console); the auxiliary high-beam headlight system is activated when the green lamp in the switch is illuminated.
- Switch on the high beams or activate the headlight flasher; the auxiliary high-beam headlights are illuminated at the same time as the regular high beams.
- The auxiliary high-beam headlights can be switched off at any time using the switch in the driver's knee bolster panel (optional: center console)

Reset mode

If the ignition is switched off and then on again, the auxiliary high-beam headlight system must be switched on again using the switch in the driver's knee bolster panel (optional: center console).

 Follow locally applicable state and regional laws concerning the operation of auxiliary high-beam headlights. For example, some states prohibit simultaneous use of four headlights; others prohibit their use on streets entirely and require that the lamps be covered with headlight covers when not in use. ◀

 Never use the auxiliary high-beam headlights when the headlamp covers are in place. This can destroy both the auxiliary high-beam headlights and the covers. ◀