

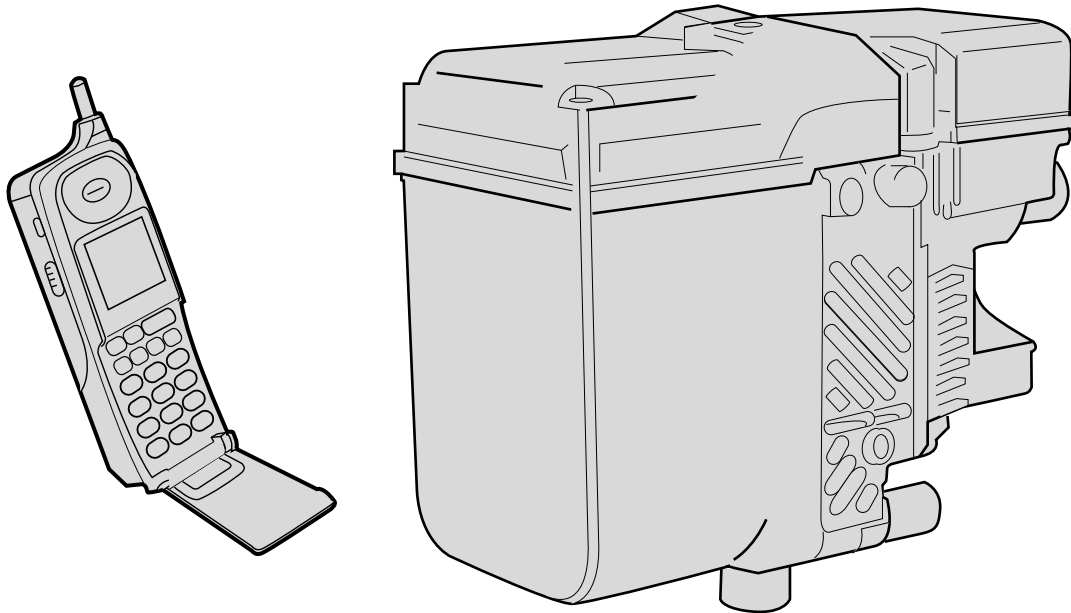

# Parts and Accessories Installation Instructions



R50 0563 Z

---

## Thermo Call 1.1 retrofit kit MINI One and MINI Cooper (R50)

The installation time is approx. 1 - 1,5 hours, but this may vary depending on the condition of the car and the equipment in it (the installation time will be reduced to 1 hour if the Thermo Call is installed at the same time as the retrofit auxiliary heating system).

Retrofit kit No.      64 50 0 150 766  
                                 64 50 0 151 224  
                                 64 50 0 151 225



In the Federal Republic of Germany the Vodafone contract and the registration form must be completed immediately after the car is accepted and then sent to the specified fax number.  
In other countries a prepaid card must be purchased on which the PIN query can be disabled.  
The phone number for Thermo Call is available from the relevant network operator. ◀

## Contents

Section	Page
Important information .....	3
1. Preparations .....	4
2. Parts list .....	5
3. Thermo Call wiring harness connection diagram .....	6
4. Thermo Call additional cable connection diagram .....	7
5. To install the Thermo Call aerial .....	8
6. To install the Thermo Call control module .....	9
7. To connect Thermo Call .....	10
8. To install the LED .....	12
9. Concluding work and programming .....	13
10. Thermo Call circuit diagram .....	14
11. How to use and test Thermo Call .....	16

## Important information

The retrofit kit is only for use within the dealership organisation.

The electrical connection of Thermo Call is made in parallel to the connection **X18830** of the receiver for the auxiliary heating system. This is located in the left-hand footwell above the clutch pedal.

The LED supplied in the retrofit kit may only be fitted if no multifunctional clock or remote control is fitted.

Do not kink or damage the cables as you install them.

If the specified PIN chambers are occupied, bridges, double crimps or twin-lead terminals must be used.

This Thermo Call retrofit kit does not require coding.

## Target group

The target group for these installation instructions is specialist personnel trained on MINI cars with specialist knowledge of vehicle electrical systems.

Work:

All servicing, repair and installation work on MINI cars is completed at your own risk.

All work is to be carried out using current MINI repair manuals and circuit diagrams in a rational order using the prescribed tools (special tools) and observing current health and safety regulations.



The SIM card must be inserted before you install the Thermo Call control module.

Do not insert or remove the SIM card when the Thermo Call control module is connected to the voltage supply. This will cause damage to the module or to the SIM card. ◀

## Thermo Call licence

European Union and conformity states

Directive 95/54/CE

Regulation No. 10 ECE-ONU/2

e3\*72/245\*95/54\*7001\*00

E3 10R-02 7001-00

## Special tools required

DISPlus, MoDiC III or GT-1

## 1. Preparations

	<b>TIS instruction No.</b>
Conduct a brief test	
Disconnect the negative pole of the battery	12 00 ...
<b>The following components must be removed first of all:</b>	
Oddments box on the driver's side	51 16 392
A pillar trim at the front left	51 43 201
Interior mirror	51 16 060

## 2. Parts list

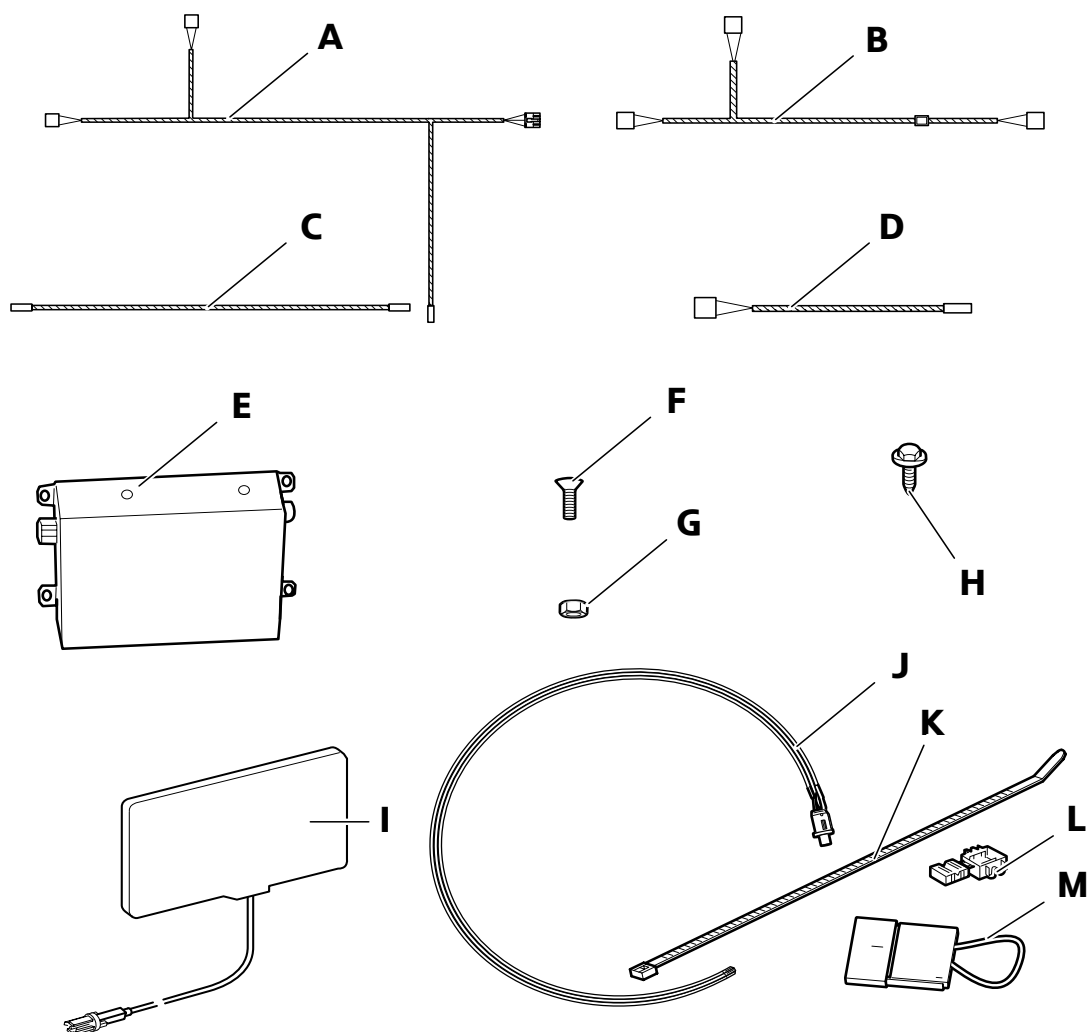

R50 0560 Z

### Legend

- A Thermo Call wiring harness
- B Thermo Call wiring harness extension (not required)
- C LED extension (not required)
- D Adapter cable (not required)
- E Thermo Call control module
- F Countersunk screw M4 x 25 mm (4x)
- G Hexagonal nut M4 (4x)
- H Fillister head self-tapping screws St 2.9 x 25 (4x)
- I Aerial
- J LED
- K Cable tie (20x)
- L Connector (4x)
- M Cable bridge

### 3. Thermo Call wiring harness connection diagram

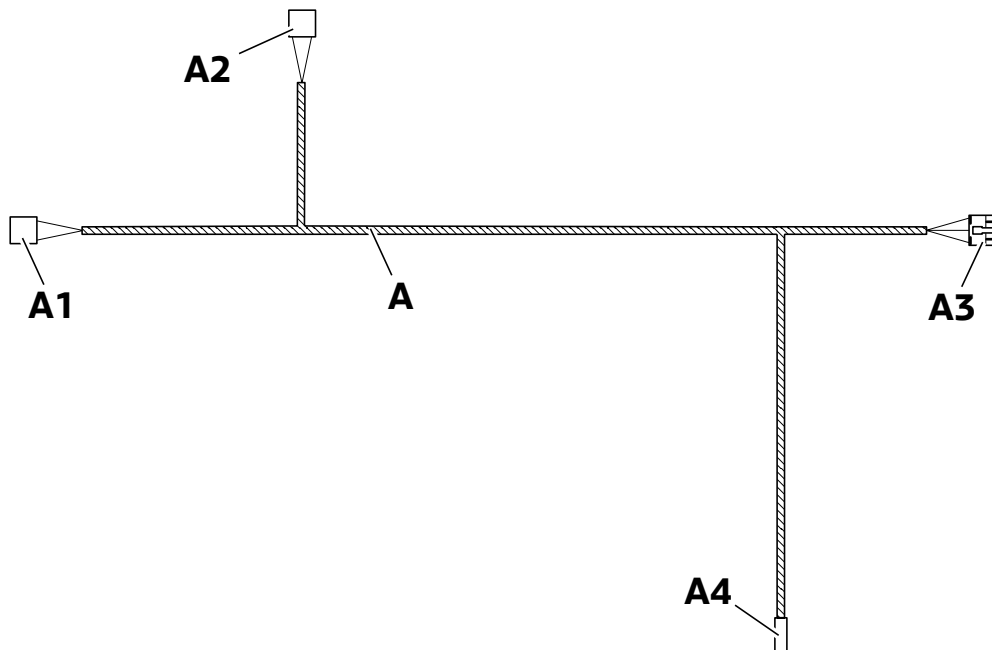

R50 0561 Z

Item	Description	Signal	Cable colour / Cross-section	Connection location in the car	Abbreviation / Slot
A	Thermo Call wiring harness				
A1	6-pin black plug			On the remote control receiver for the auxiliary heating system*	X3887B
A2	6-pin black plug			To the 6-pin black plug <b>X18830</b> on the auxiliary heating system wiring harness	X3887S
A3	12-pin black plug			To Thermo Call control module	X18130
A4	4-pin plug, white			To the LED <b>J</b>	X4763

\*If no remote control is fitted, connect the bridge **M** to the branch **A1**.

#### 4. Thermo Call additional cable connection diagram

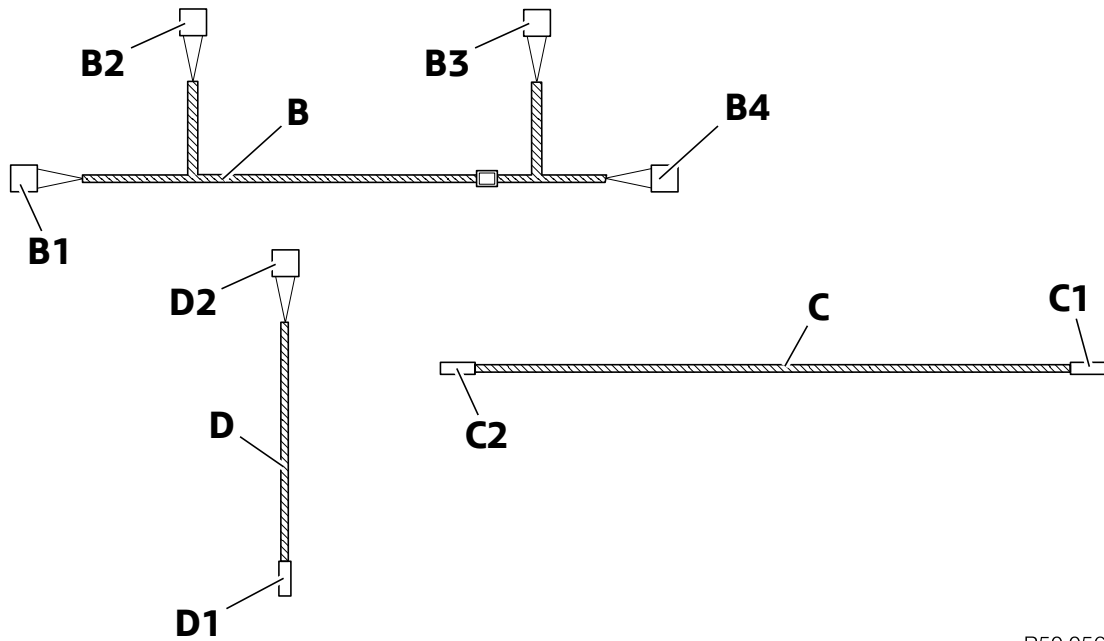

R50 0562 Z

 Additional cables **B**, **C** and **D** are not required. ◀

## 5. To install the Thermo Call aerial

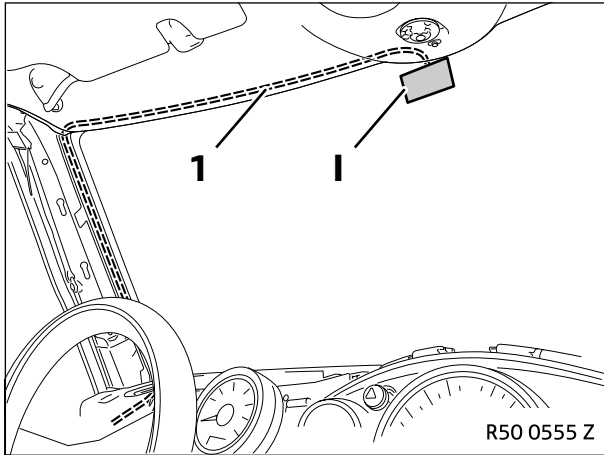

Install the aerial cable (1) in such a way that the deployment of the head airbag is not impeded. ◀

Clean the windscreen in the area where the aerial is to be affixed.

The gluing temperature must be at least 20°C.

Affix the aerial I on the left next to the rear-view mirror.

Lay the aerial cable (1) along the standard wiring harness to the installation site of the Thermo Call control module.

## 6. To install the Thermo Call control module

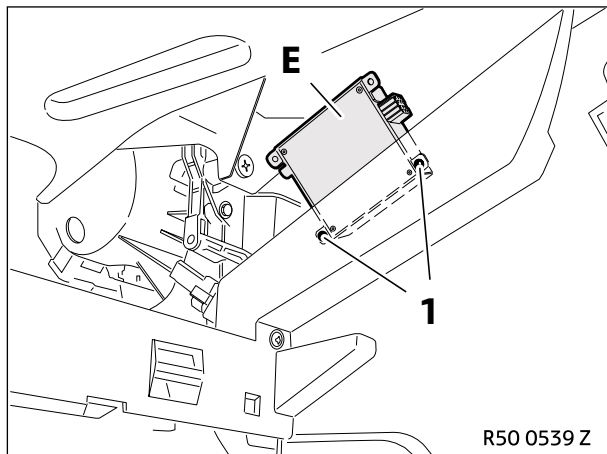

Place the Thermo Call control module **E** against the centre console and mark the holes (1).

Drill the holes with a 6 mm drill bit.

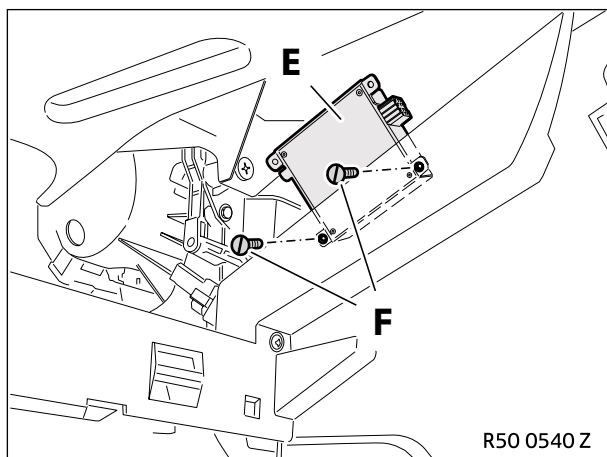

Secure the Thermo Call control module **E** with countersunk screws **F** and hexagonal nuts **G** (not shown).

## 7. To connect Thermo Call

Cars without T70/T80 remote control only.

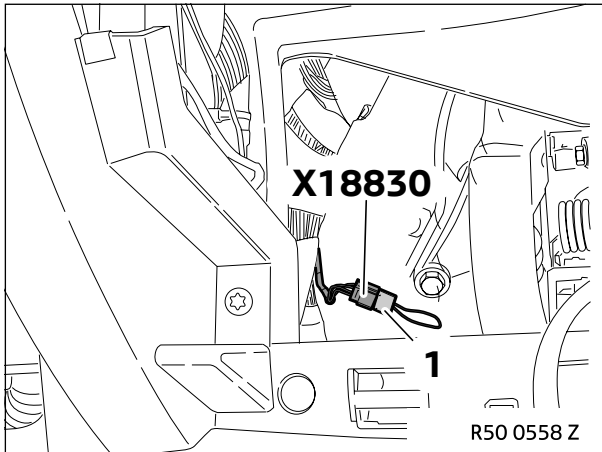

Disconnect the cable bridge (1) from the plug **X18830**.

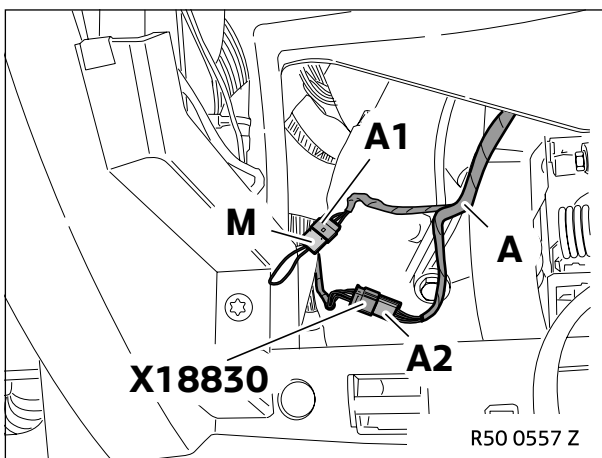

Connect branch **A2** to the plug **X18830**.

Place a cable bridge **M** on branch **A1**.

Lay the wiring harness **A** to the installation site of the Thermo Call control module.

## 7. To connect Thermo Call

### Cars with T70/T80 remote control only.

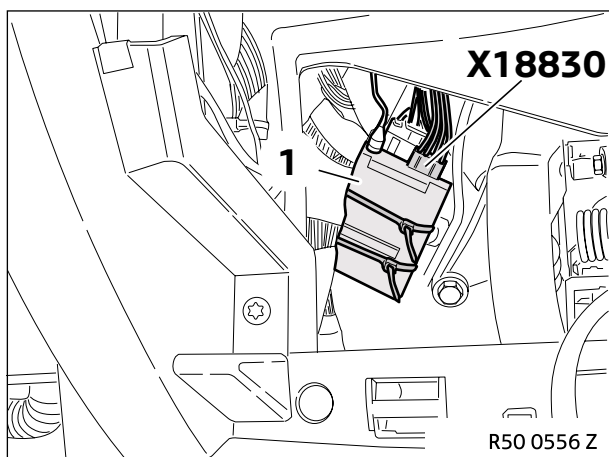

Disconnect the plug **X18830** from the receiver (1).

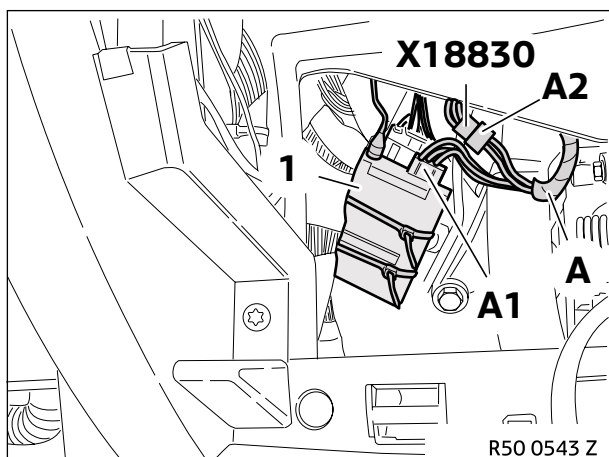

Connect branch **A2** to the plug **X18830**.

Connect branch **A1** to the receiver (1).

Lay the wiring harness **A** to the installation site of the Thermo Call control module.

### All cars

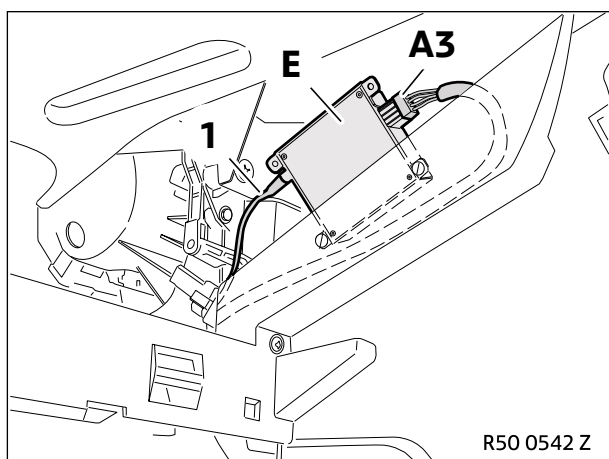

Connect the aerial cable (1) and branch **A3** to the Thermo Call control module **E**.

## 8. To install the LED

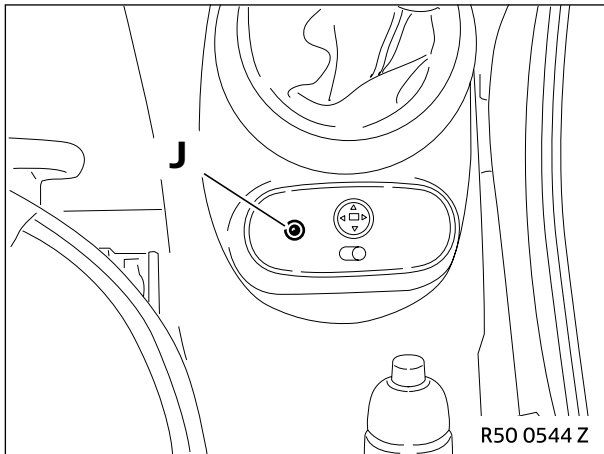

The LED supplied in the retrofit kit may only be fitted if no multifunctional clock or remote control is fitted. ◀

Mark the position of the hole for the LED **J** on the centre console.

Drill the hole with a diameter of 8.1 mm.

Insert the LED **J** and check that it moves easily. If necessary enlarge the hole a little with a round file.

Lay the LED connection cable **J** to the installation site of the Thermo Call control module.

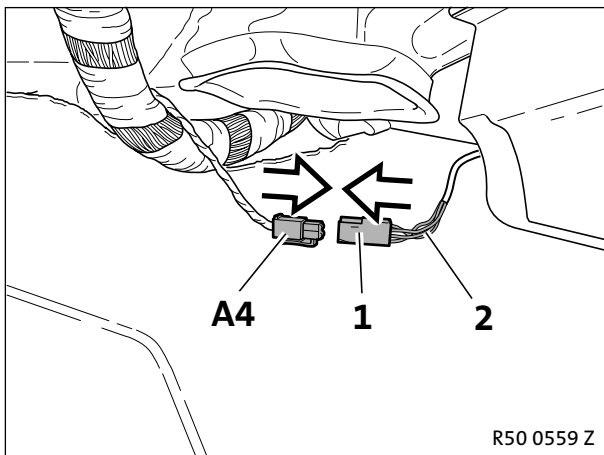

Connect the plug (1) to branch **A4**.

Connect the connection cable (2) to the cables of the same colour in the plug (1).

## 9. Concluding work and programming

- This Thermo Call retrofit kit does not require coding.
- Assemble the car again following the instructions to dismantle it in reverse order.

### To program Thermo Call



The Thermo Call may only be programmed if you have not fitted the LED. If you program it when the LED has been fitted, it will suffer from malfunctions. ◀

- Call Thermo Call.
- When you are asked to enter the password, enter the following technician password:
- \*1901\*
- and then enter the following number:
- \*1\*
- This concludes the programming.

The precise instructions for operating the Thermo Call are set out in section 11 or the separate owner's handbook.

# 10. Thermo Call circuit diagram

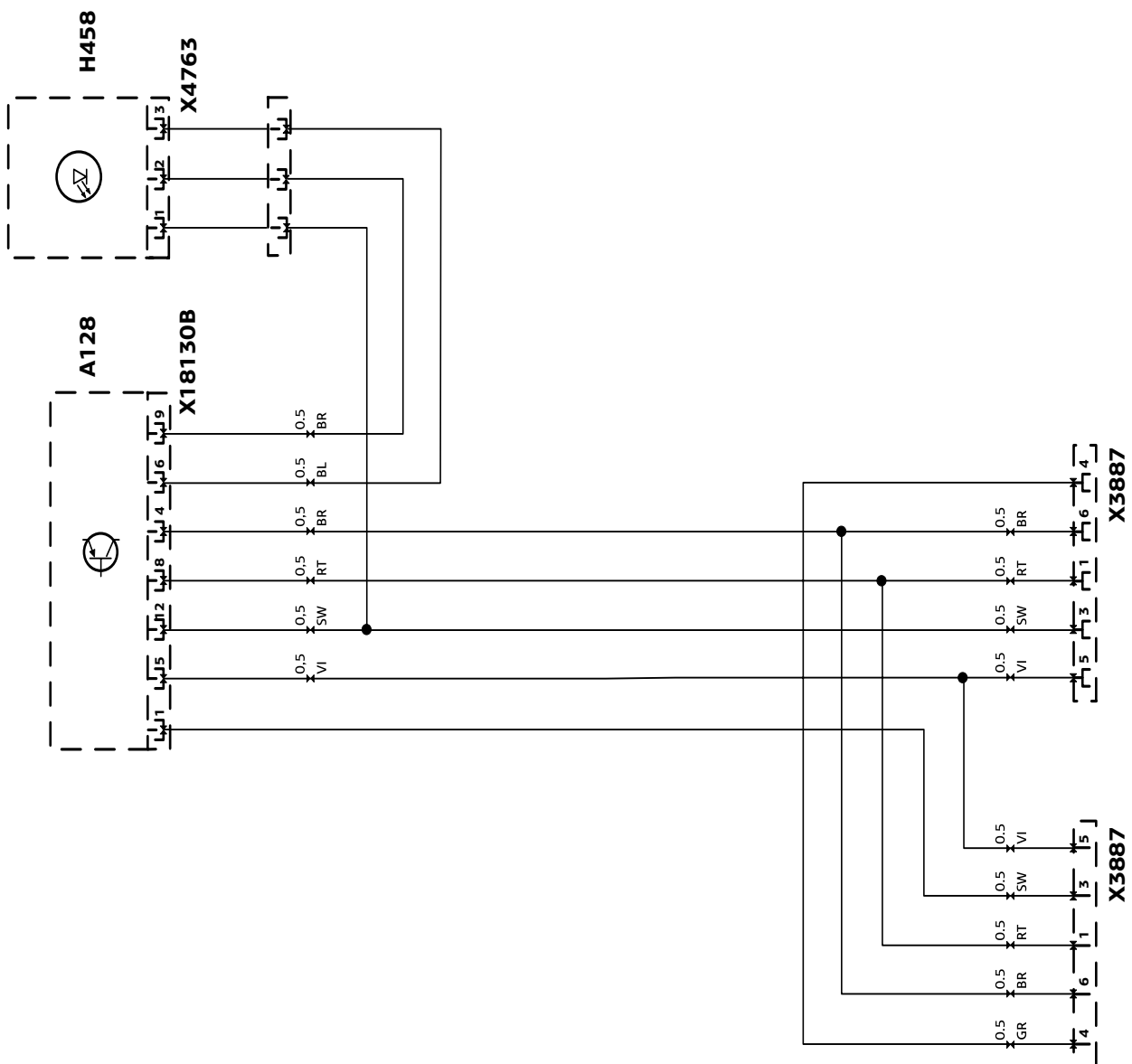

R50 0541 Z

## 10. Thermo Call circuit diagram

### Legend

A128	Thermo Call control module
H458	LED
X3887	6-pin black plug
X4763	4-pin white plug
X18130B	12-pin black socket contact plug

### Cable colours

BL	blue
BR	brown
GE	yellow
GN	green
GR	grey
OR	orange
RT	red
SW	black
VI	violet
WS	white

## 11. How to use and test Thermo Call



The SIM card must be inserted before you install the Thermo Call control module.

Do not insert or remove the SIM card when the Thermo Call control module is connected to the voltage supply. This will cause damage to the module or to the SIM card. ◀

The complete description of the Thermo Call is set out in the owner's handbook supplied with the retrofit kit. You should set the time in Thermo Call before you hand the car back to the customer.

### General instructions for Thermo Call

Thermo Call makes it possible to operate the auxiliary heating system by phone. The telephone must support the transmission of multi-frequency dial tones.

When it is supplied the password is set to 00 and should only be changed by the customer.

### To test Thermo Call

- Call Thermo Call.
- When you are asked for the Thermo Call password, enter it and confirm it by pressing #.
- Switch on the auxiliary heating system by pressing 1.
- The Thermo Call confirms your entry.
- Break the connection.
- Check the function of the auxiliary heating system.
- Allow the auxiliary heating system to run for a few minutes.
- Call Thermo Call.
- When you are asked for the Thermo Call password, enter it and confirm it by pressing #.
- Switch off the auxiliary heating system by pressing 1.
- The Thermo Call confirms your entry.
- Break the connection.
- The auxiliary heating system will stop heating the car but will continue to operate for approx. three minutes.