

## AccessPORT Installation

### Pre-Installation

The AccessPORT comes with the most up-to-date software available at the time of shipment. However, it is possible that updated software and/or map files have been made available since the time of shipment. Therefore, the recommended procedure is to connect the AccessPORT to the AP Updater software and download the latest software and map files for the target vehicle.

#### **IMPORTANT!**

**Before installing the AccessPORT on the vehicle, it is important to verify that the vehicle is adequately prepared for the installation process. Since the AccessPORT uses the vehicle's battery for power and the ECU reprogramming process requires adequate battery power as well, it is critical to verify that the vehicle's battery has a good charge. This can be done through the use of a battery charger/conditioner or by driving the vehicle for a period of time prior to installation to allow the alternator to recharge the battery. Furthermore, please ensure that all in-car electronic devices are turned off to reduce power draw on the battery. This includes car stereos, video screens, GPS units, radar detectors, interior and exterior vehicle lights, and any other electronic device that uses the car battery for power.**

### Getting Started

1. Insert the key into the vehicle's ignition.

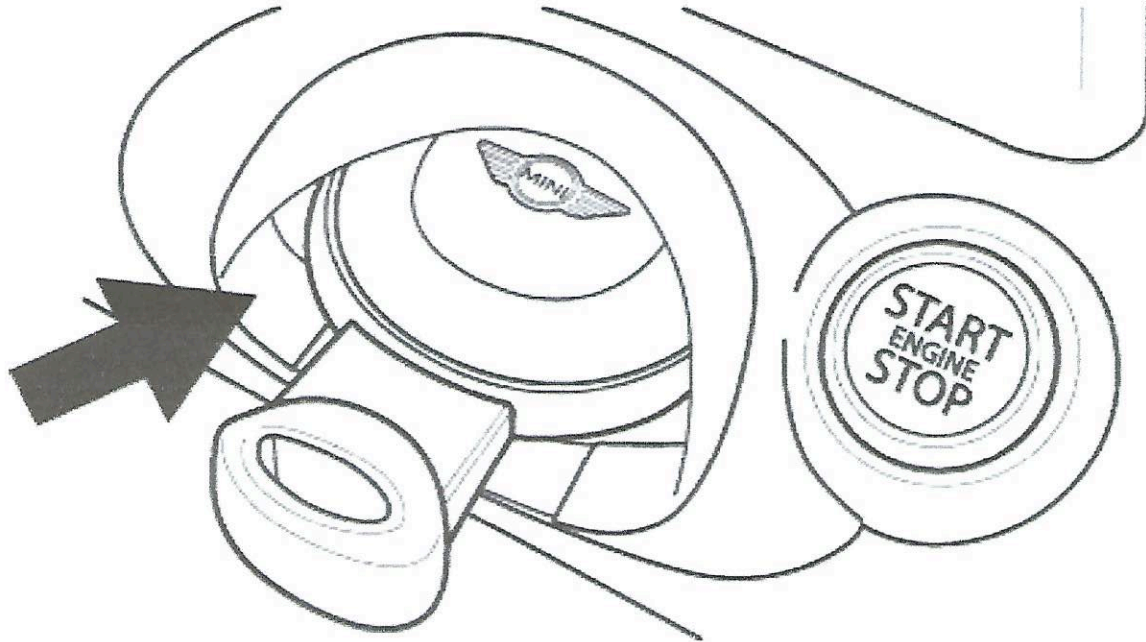

2. Locate the vehicle's OBD-II port under the left hand side of the driver's side dash.

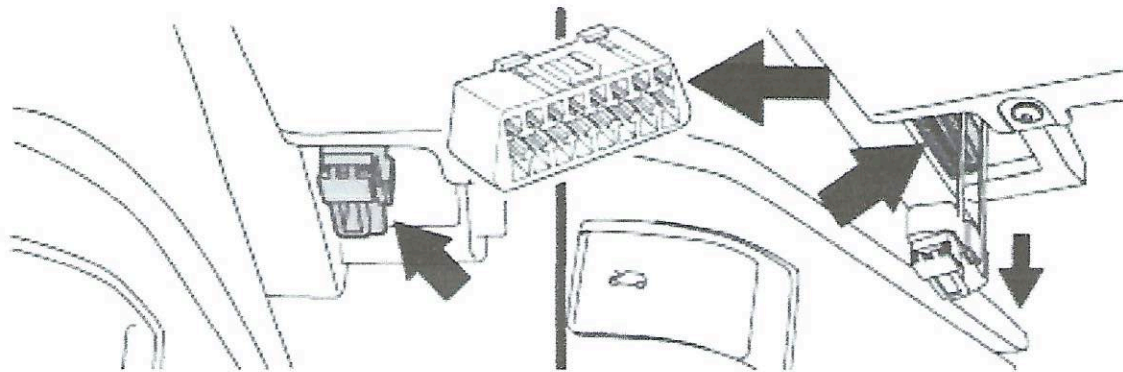

3. Plug the OBD-II cable into the OBD-II port under the dash.

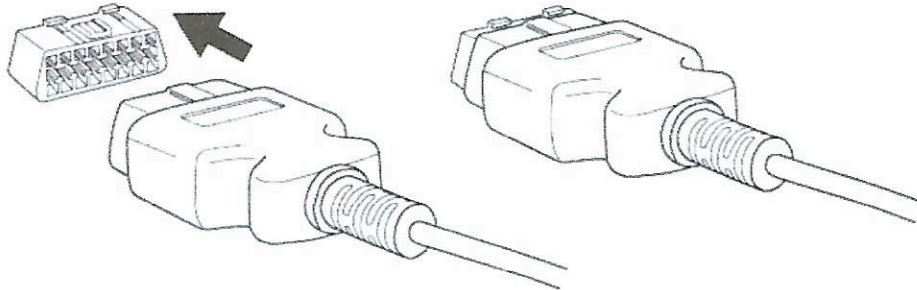

4. Connect the small end of the OBD-II cable to the 10-pin port on the bottom of the AccessPORT. At this point the AccessPORT will power up and after a few moments present the installation menu.

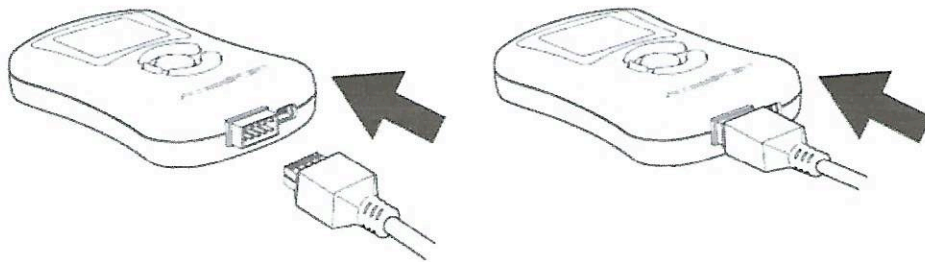

5. Make sure the clasp on the OBD-II cable firmly engages the tab on the 10-pin port.

