

[MINI F60 Cooper S ALL4 SAV / Repair Manuals and Technical Data / 11 Engine / 11 28 Drive belt with tensioning and deflecting element /](#)

11 28 020 Replacing alternator drive belt tensioner

PRELIMINARY WORK

1 – Disconnecting all battery earth leads



- See additional information.

2 – Removing the acoustic cover



Hot surfaces.

Risk of burning!

- Perform all work only on components that have cooled down.

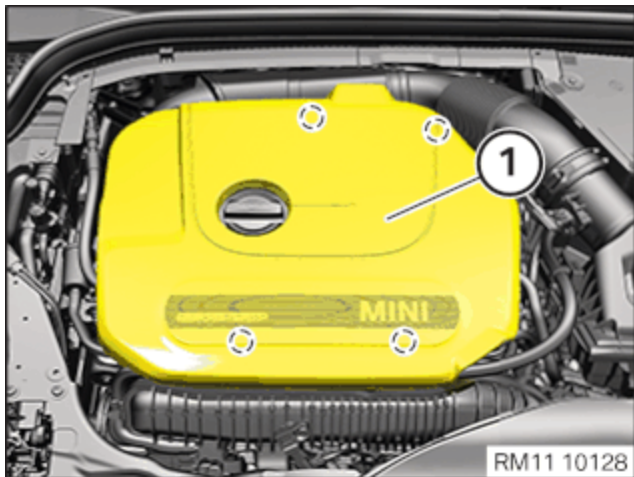

Damage to the acoustic cover/design cover.
Jerky movements during disassembly and excessive application of force during installation may result in breakage of the acoustic cover/design cover.

- Disassemble or mount the acoustic cover/design cover carefully.
- Disassemble or mount snap-lock couplings of the ball pivots one after the other.
- Disassemble or mount acoustic cover/design cover only at temperatures $>20\text{ }^{\circ}\text{C}$.
- Use only distilled water as an auxiliary material during installation, no lubricants.

- Clip out the acoustic cover (1) upwards from the marked areas.

3 – Removing intake port

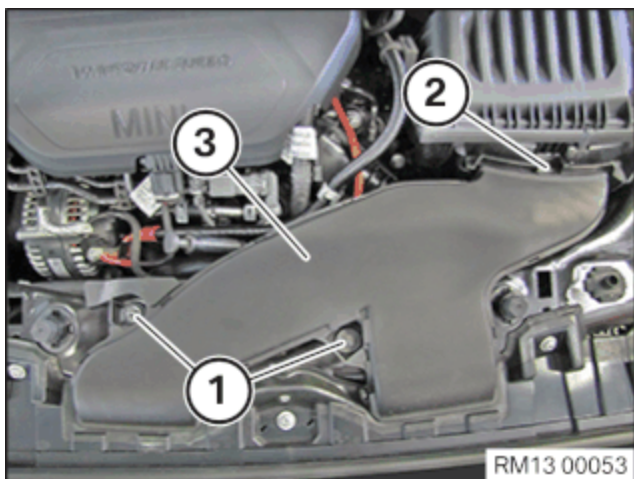

- Loosen nuts (1).
- Loosen the lock (2).
- Feed out intake port (3) and remove.

4 – Removing intake silencer housing

Prerequisite

Ignition is switched off.

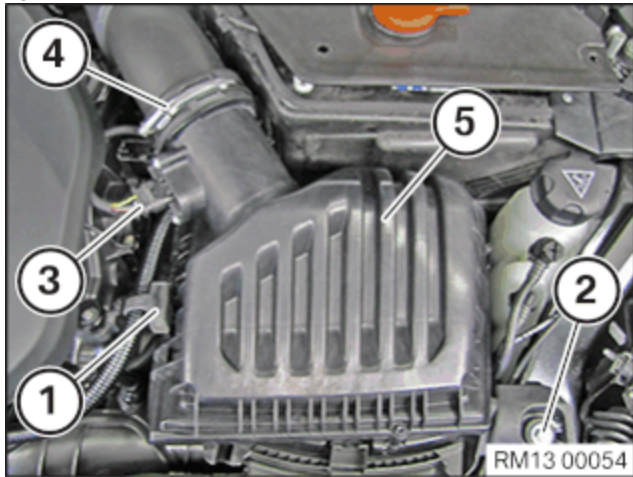

- Pull off rubber retainer (1) from intake filter housing.
- Loosen screw (2).
- Unlock connector (3) and pull off from hot film air mass meter.
- Release clamp (4) and detach the clean air pipe from the intake filter housing.
- Pull out and remove the intake silencer housing (5) from the rubber mounts towards the top.

5 – Remove cross connection

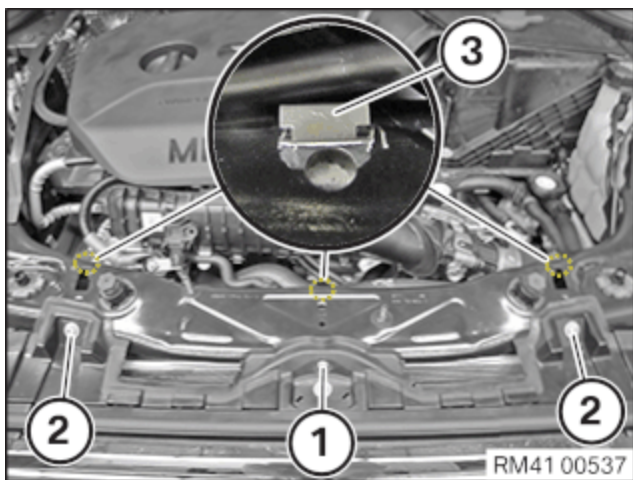

- Loosen screws (1) and (2).
- Detach clamps (3) for bonnet lock Bowden cable.

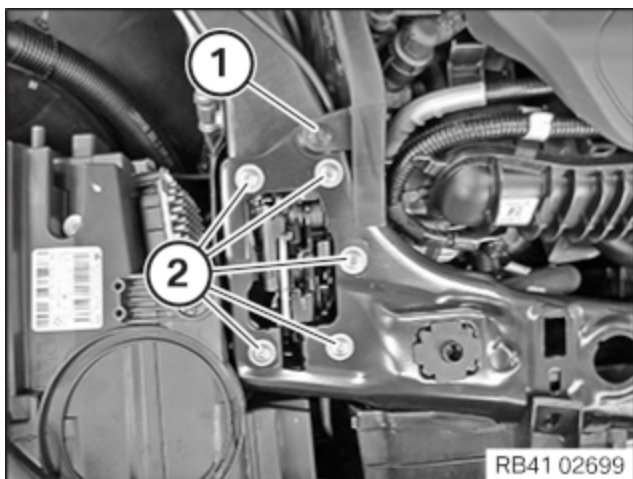

- Lever out expanding rivet (1).
- Loosen screws (2).

- If necessary, lever out expanding rivet (1).
- Loosen the screws (2) and remove the cross connection (3).

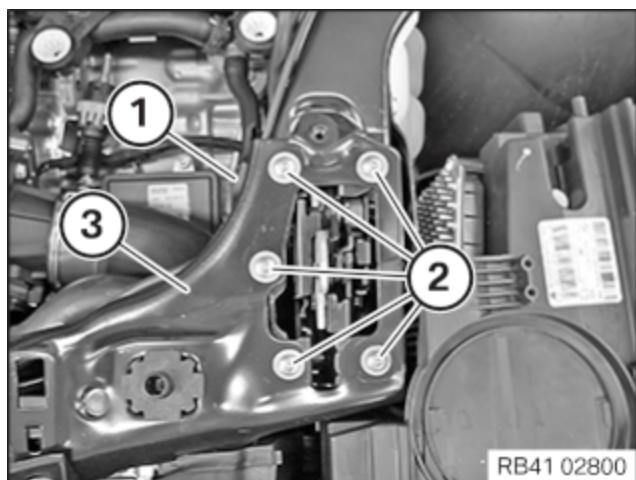

6 – Remove tank vent valve

- **Version: A**

Unlock plug connection (1) and disconnect.

Unlock and pull off the tank ventilation line (2).

Unlock and disconnect the tank ventilation line (3) from the throttle body.

Detach the tank vent valve (4) from the holder and remove it.

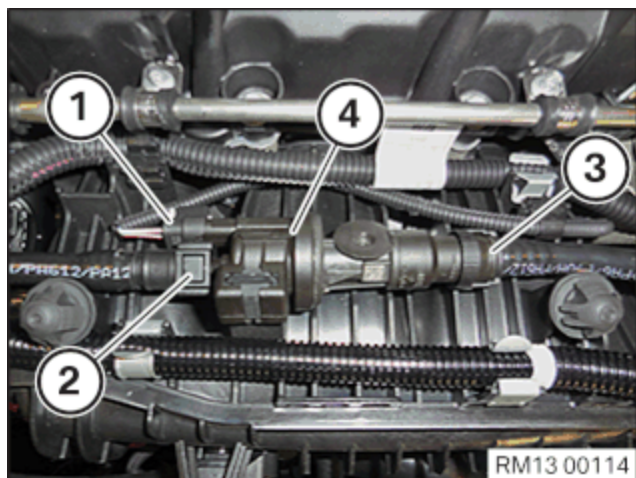

- **Version: B**

Unlock plug connection (1) and disconnect.

Unlock and pull off the tank ventilation line (2).

Unlock and disconnect the tank ventilation line (3) from the throttle body.

Detach the tank vent valve (4) from the holder and remove it.

Detach the tank vent valve (5) from the holder and remove it.

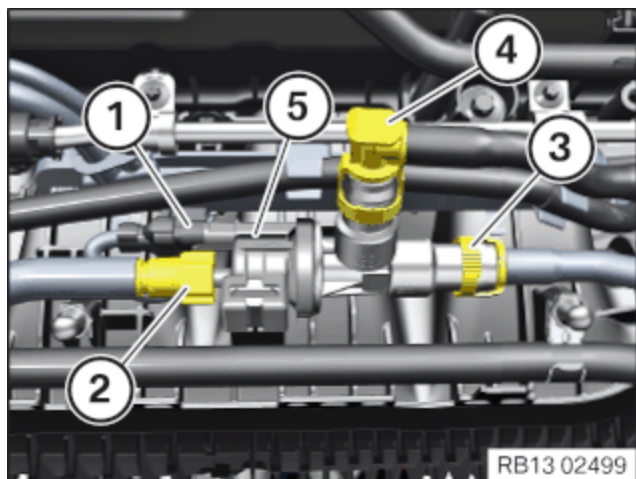

7 – Removing the servomotor for the eccentric shaft



Hot surfaces.

Risk of burning!

- Perform all work only on components that have cooled down.



Electrostatic discharge.

Damage to or destruction of electrical components.

- Leave electrical components in original packaging until just before they are installed. Use the original packaging only for any return shipments. Always package removed components straight away.
- Read and comply with user information on using the associated special tool 12 7 060.
- Only touch the housings of electrical components. Do not touch pins or multi-pin connectors directly.
- Wear electrically conductive clothing and antistatic shoes (with ESD symbol).
- For additional information see: 61 35 ... Notes for ESD protection (electrostatic discharge)



Contaminant or foreign body.

Contamination can result in malfunctions, operating failure or leaks.

- Adhere to the utmost cleanliness.
- Protect components from contamination e.g. by covering.
- Close off line connections with seal plugs.



Collect and dispose of emerging fluids. Observe country-specific waste disposal regulations.

- Unlock and loosen connector (1).

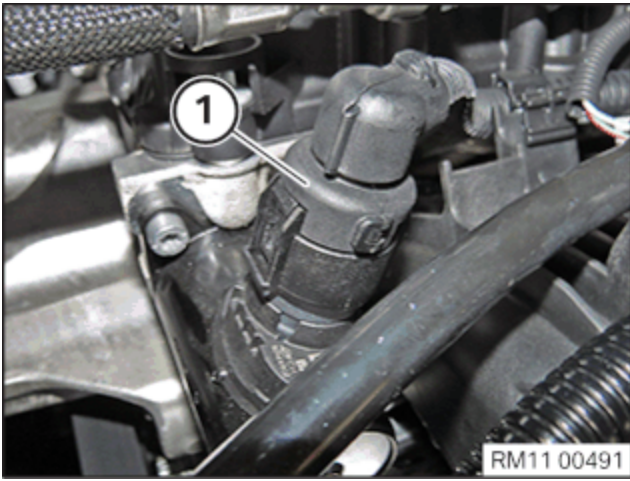

- Loosen screws (1).

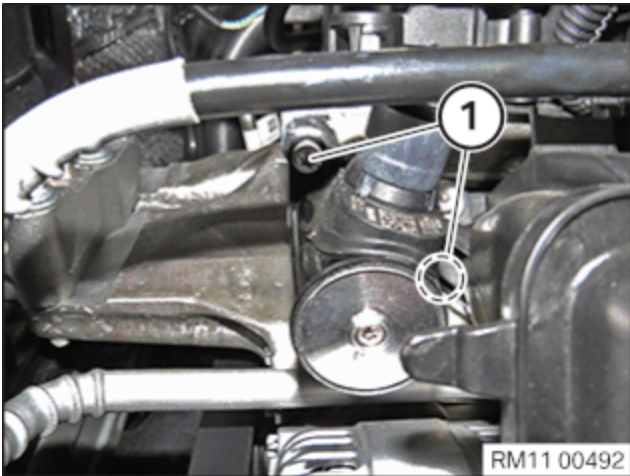

- Turn the drive shaft of the servomotor (1) with a standard tool (2) in the direction of the arrow.
- Make sure that the drive shaft of the servomotor (1) is not turned beyond the end stop of the eccentric shaft.
- Guide out and remove the servomotor (1).
- Catch and dispose of emerging engine oil.

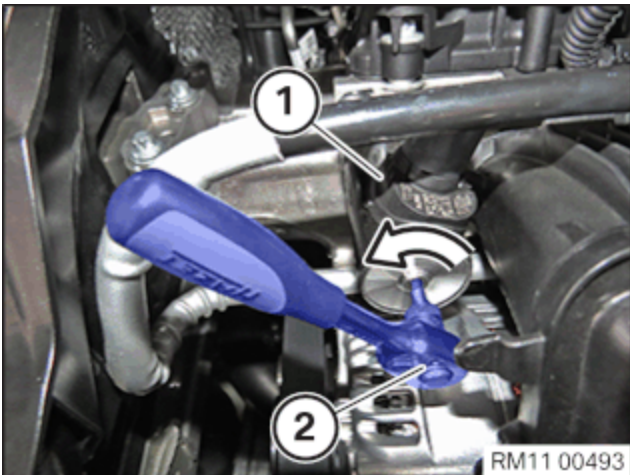

8 – Removing the intake plenum



Hot surfaces.

Risk of burning!

- Perform all work only on components that have cooled down.

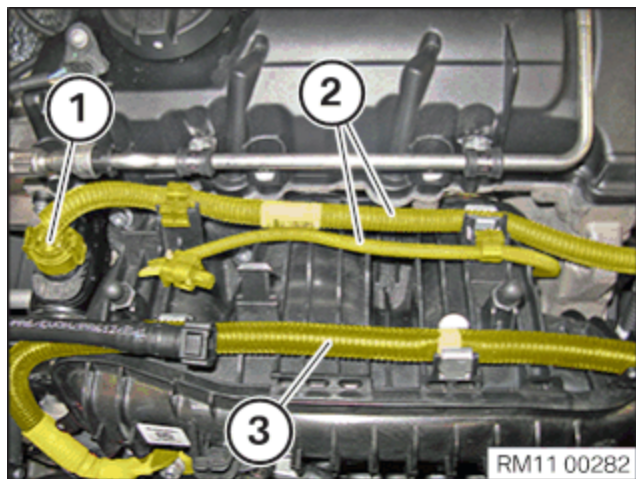

- Unlock and detach the connector (1) from the VTC controller.
- Unclip the wiring harness (2) from the intake plenum.
- Unclip the positive battery cable (3) from the alternator and detach it from the intake plenum.

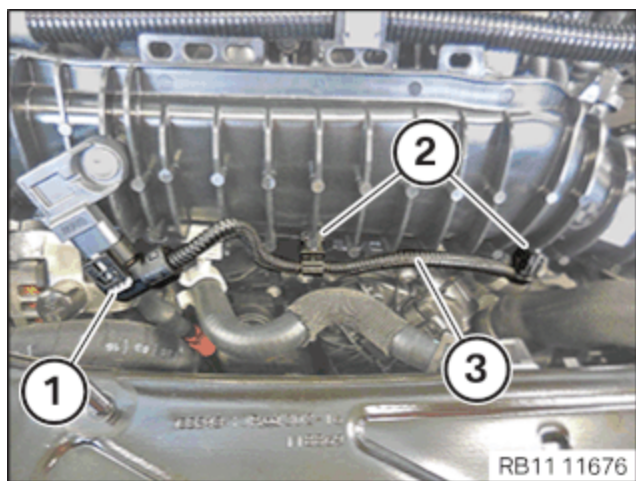

- Unlock and loosen the connector (1) on the charging pressure sensor.
- Loosen clamps (2).
- Feed the wiring harness (3) out of the intake plenum and set it aside.

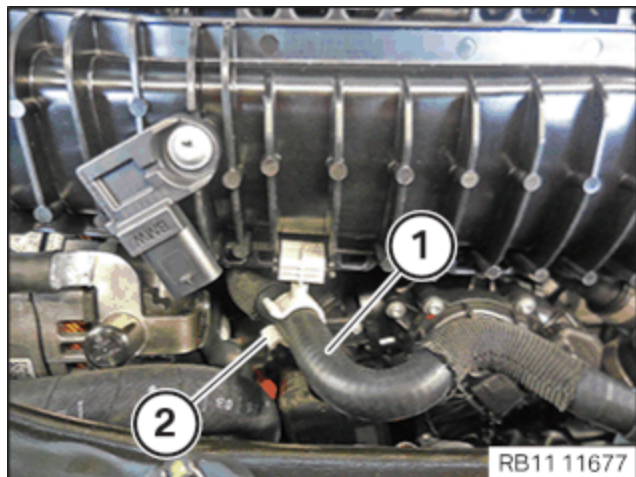

- Feed out coolant line (1) from the holder (2) and place to one side.

- Loosen screws (1).
- Guide the fuel feed line (2) out and set it aside.

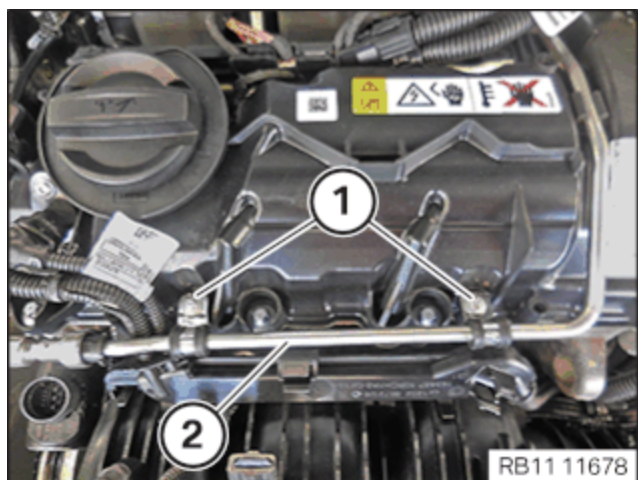

- Unlock the locks (arrows).
- Feed out cable channel (1) and set it aside.

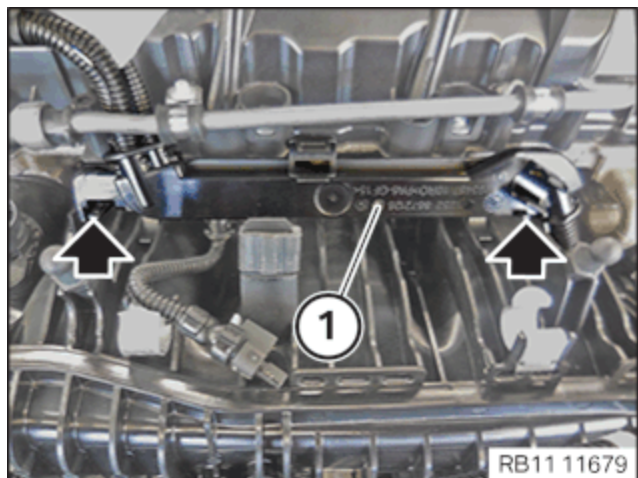

- The locks (1) must engage in the bracket (arrows).

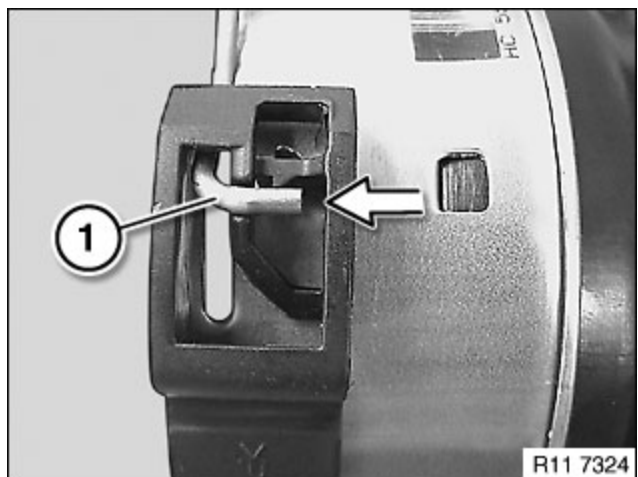

- Unlock and loosen the connector (1) on the charging pressure sensor.
- Unlock and disconnect the connector (2) from the throttle valve.
- Unlock the pressure pipe (3) and disconnect it from the throttle body.
- Remove the pressure pipe (3) and put to one side.

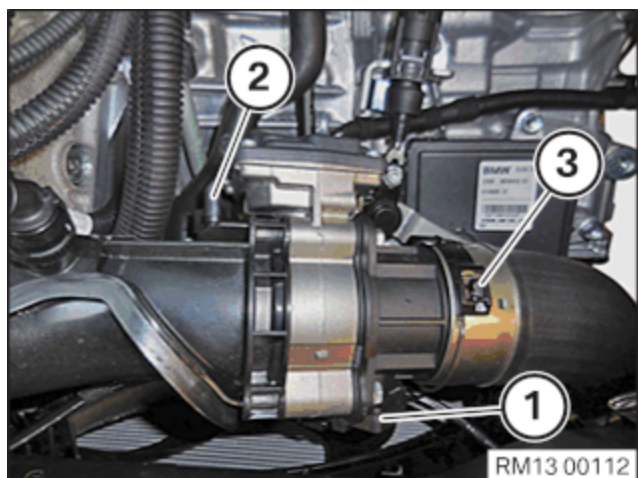

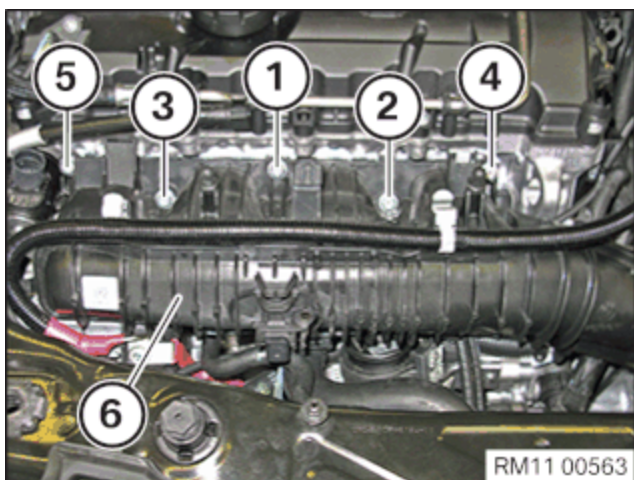

- Release the bolts in the sequence (5), (4), (3), (2), (1).
- Feed out the intake plenum (6) from the cylinder head and remove it.

9 – Remove front right wheel



Description is for left component only. Procedure on the right side is identical.



Schematic diagram is for example purposes. Some parts may differ in certain details.

► Removing the wheel



- If several wheels are removed simultaneously, mark each tyre with a piece of chalk to show the axle and side on which the corresponding wheel is fitted.
- Unscrew the wheel bolts (arrows) and remove the wheel.



The following work step(s) is / are to be carried out if the specified component(s) is/are fitted.

- To unscrew and tighten the wheel bolts with locking wheel bolts (2), use the correct adapter (1) from the set of special tools .

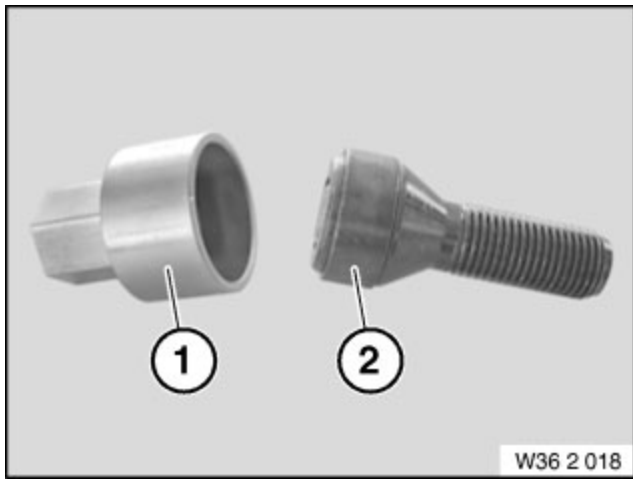

10 – Remove front right wheel arch cover



Description is for left component only. Procedure on the right side is identical.

► Remove front wheel arch cover

- Open the expanding rivets in area (1).
- Loosen nuts (2).
- Remove screws (arrows).
- Detach the clip (3) and feed out the wheel arch cover (4).

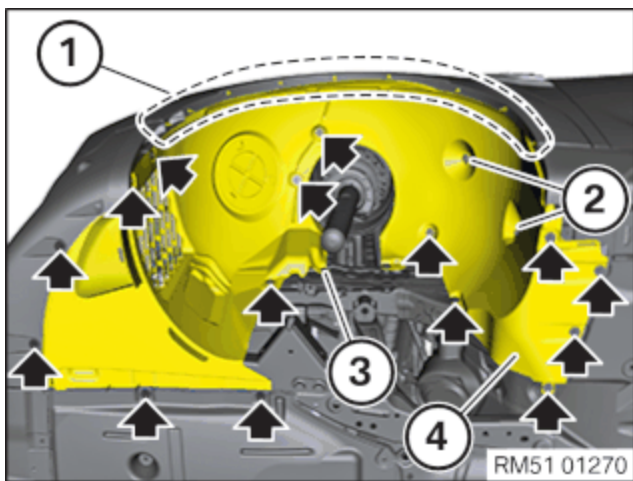

11 – Partly removing the washer fluid reservoir

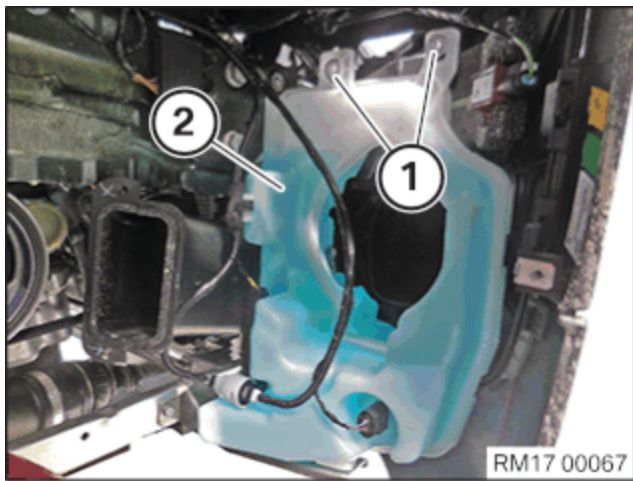

- Loosen screws (1).
- Lift the washer fluid reservoir (2) a bit upwards and set it aside.

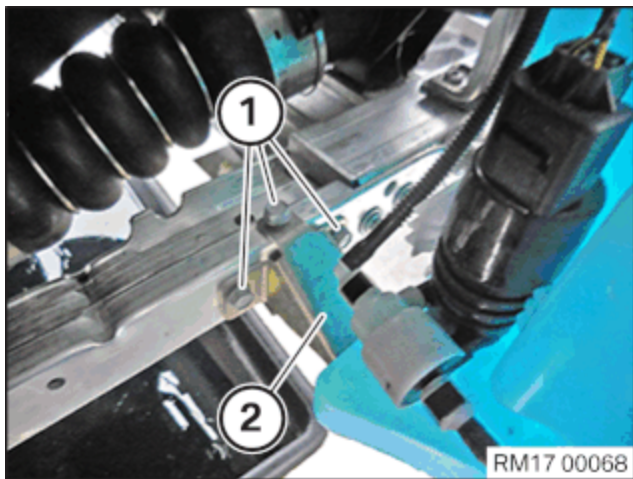

- Loosen screws (1).
- Remove the holder (2) for the washer fluid reservoir.

12 – If installed: Removing the right brake air duct

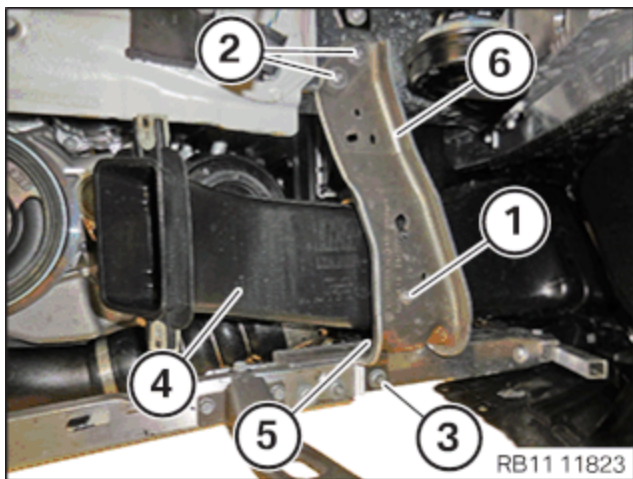

- Release screws (1), (2) and (3).
- Thread out the brake air duct (4) and put to one side.
- Loosen screw (5).
- Thread out and remove the brake air duct (4) and brace (6).

13 – Remove drive belt



Spring preload.

Danger of injury!

- The use of the specified special tool (tool) is mandatory.
- The described operation must be carried out properly.



Component with preload.

Danger of injury!

- Reduce preload as far as possible before disassembly. Relieve component.



If the drive belt is reused: Mark direction of travel and reinstall drive belt in same direction of travel.



The drive belt must be replaced if contaminated with coolant- and oil residues.

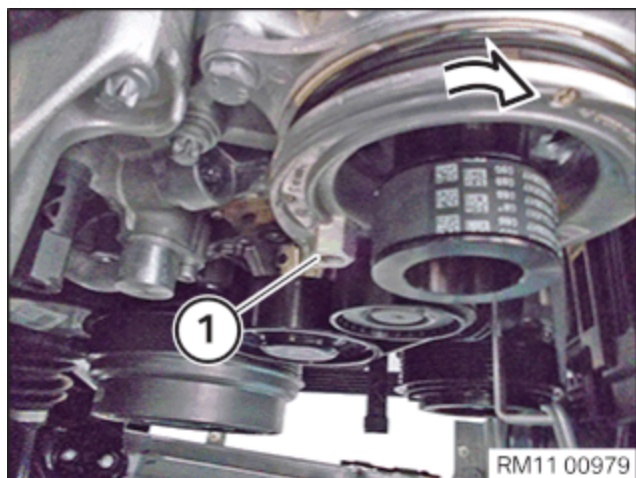

- If reusing drive belt: Mark the direction of rotation.
- Increase the preload of the belt tensioner on the hexagon head (1) in direction of arrow until the bore holes are aligned.

- Secure the belt tensioner with the special tool **0 496 268 (11 0 390)**.

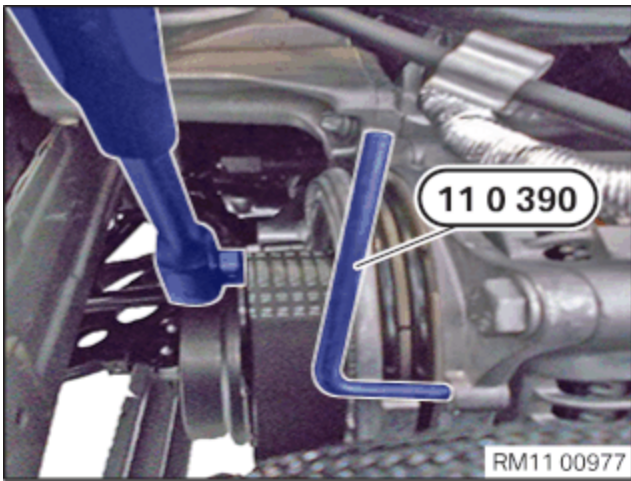

- Remove the drive belt (1).

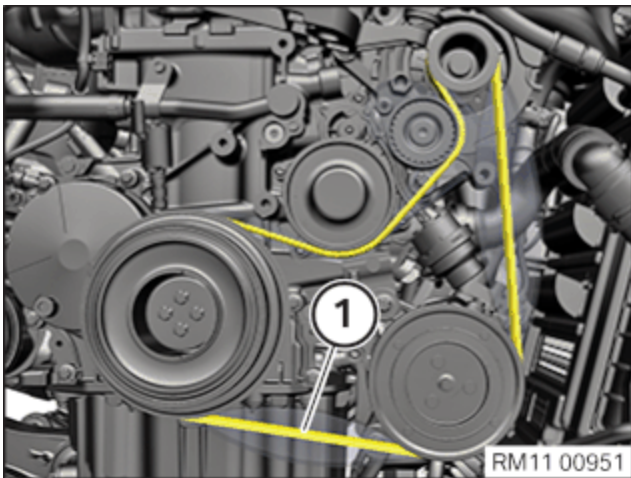

14 – Removing the alternator



Working on 12 V vehicle electrical system.

Risk of short circuits! Risk of fire!

- Make sure that **no charger** is connected to the jump start support point in the engine compartment.
- Detach battery earth lead from battery.
- With auxiliary batteries: Detach all battery earth leads from additional batteries.



Hot surfaces.

Risk of burning!

- Perform all work only on components that have cooled down.



Electrostatic discharge.

Damage to or destruction of electrical components.

- Leave electrical components in original packaging until just before they are installed. Use the original packaging only for any return shipments. Always package removed components straight away.
- Read and comply with user information on using the associated special tool 12 7 060.
- Only touch the housings of electrical components. Do not touch pins or multi-pin connectors directly.
- Wear electrically conductive clothing and antistatic shoes (with ESD symbol).
- For additional information see: 61 35 ... Notes for ESD protection (electrostatic discharge)

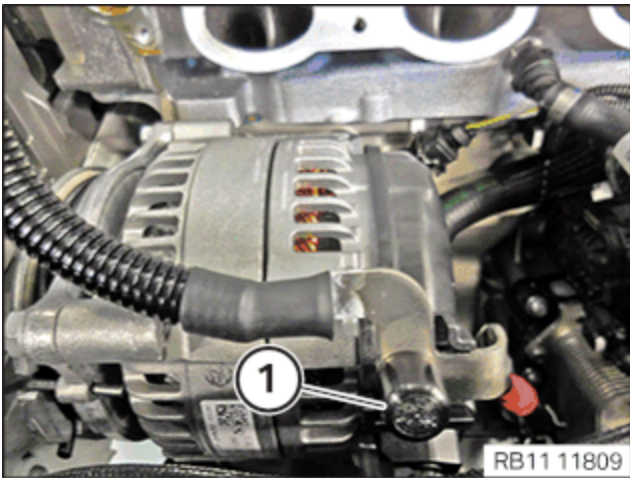

- Guide out and remove the cover (1).

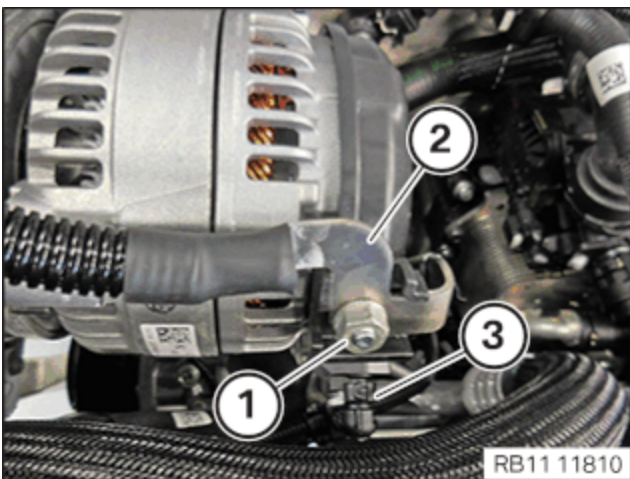

- Loosen nut (1).
- Feed out the positive battery cable (2) at the alternator and set it aside.
- Unlock plug connection (3) and disconnect.

- Loosen screw (1).

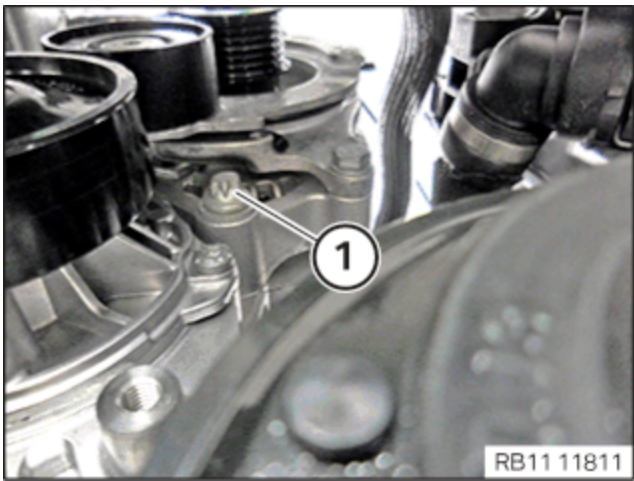

- Thread out screw (1) from alternator (2) up to limit position.

Note: Screw (1) can only be removed with the alternator (2).

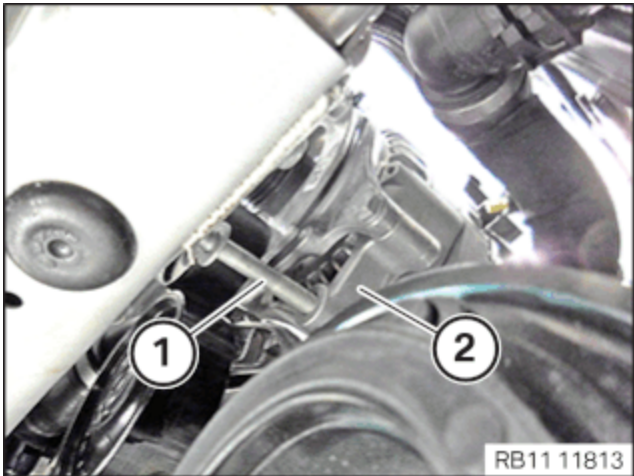

- Loosen screw (1).

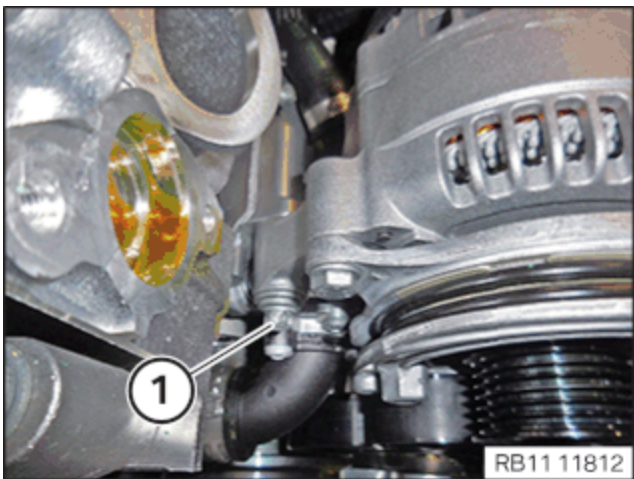

- Thread out and remove alternator (1) with screw (2).

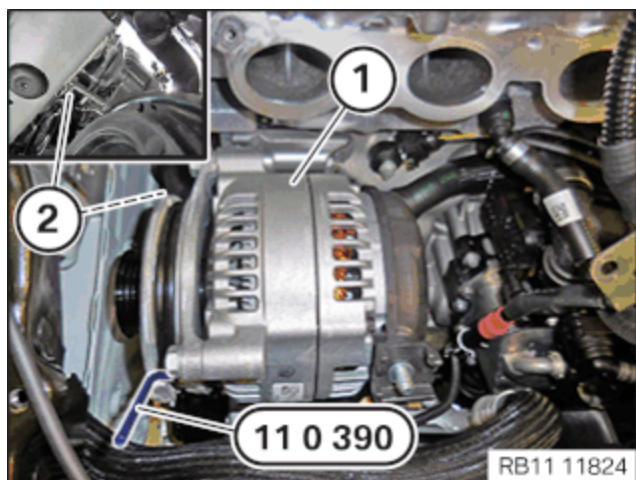

MAIN WORK

15 – Replacing the belt tensioner

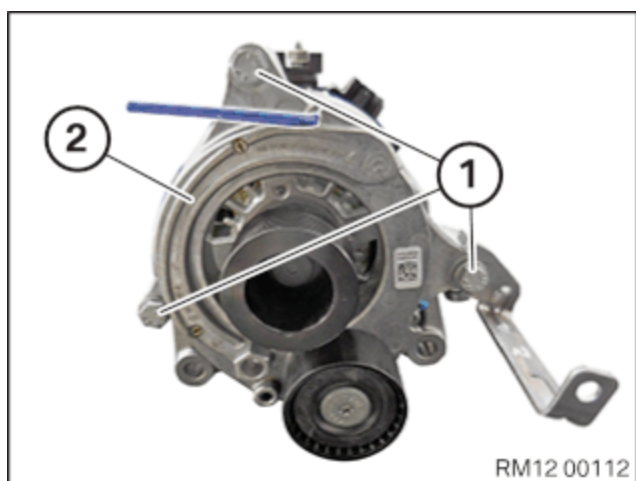

- Loosen screws (1).
- Guide out the belt tensioner (2) at the alternator and remove.

- Renew the belt tensioner.

Parts: Belt tensioner

- Feed in the belt tensioner (2) at the alternator and install it.
- Tighten the screws (1).

Belt tensioner to alternator

M8x30		Tightening torque	28 Nm
-------	--	-------------------	-------

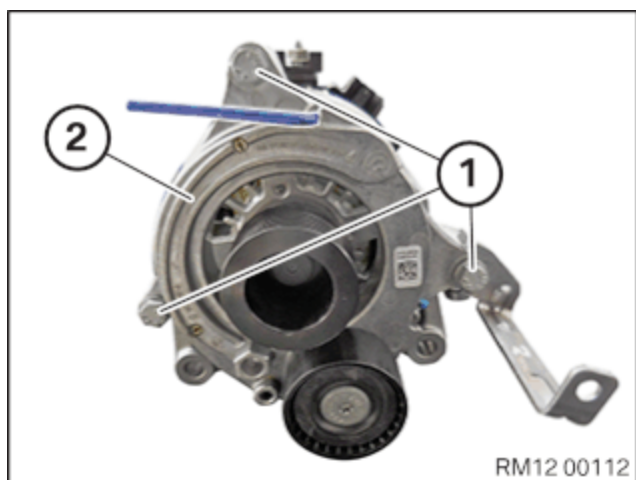

POSTPROCESSES

16 – Installing the alternator



Improper routing of the positive battery cable.

Risk of short circuits!

- Route the positive battery cable without abrasions and do not trap.

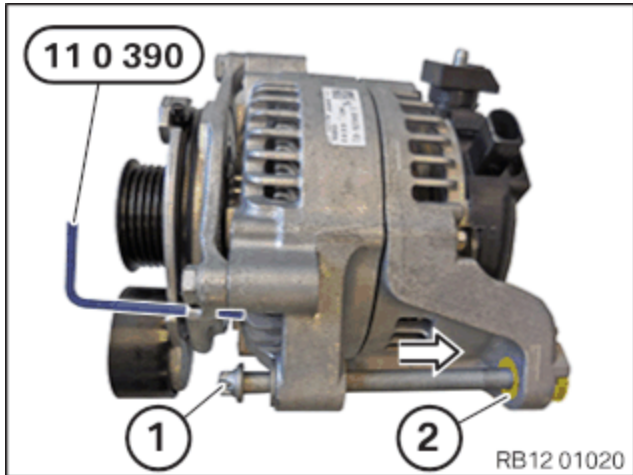

- Slightly push back the threaded support sleeve (2) in the direction of the arrow to facilitate the installation of the alternator.
- Screw the screw (1) into the threaded support sleeve (2).
- Press back the threaded support sleeve (2) using the bolt (1).
- Once again unscrew the screw (1) from the threaded support sleeve (2).

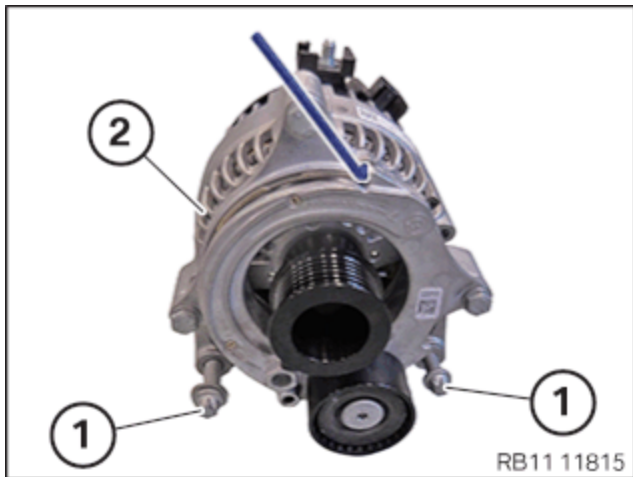

- Before installing the alternator (2), position the screws (1) in the alternator (2).

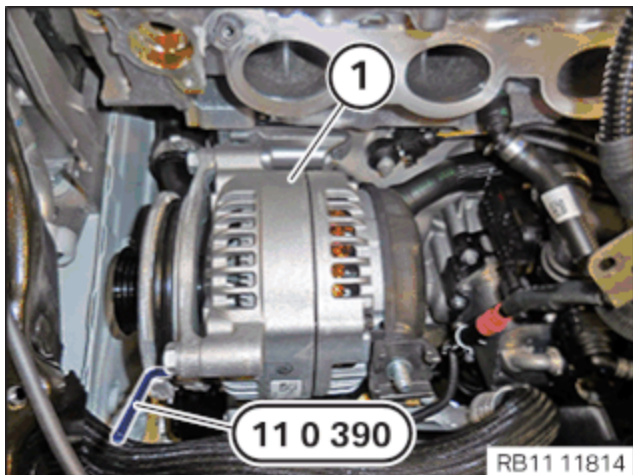

- Insert and position the alternator (1).

- Tighten down screw (1).

Alternator to holder

M10x125/M10x75		Tightening torque	38 Nm
----------------	--	-------------------	-------

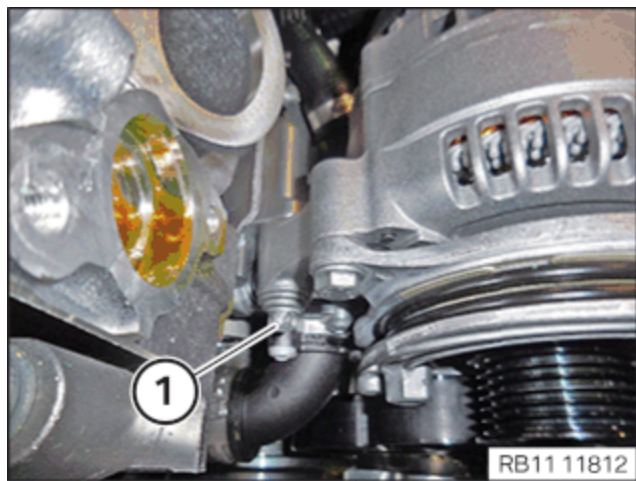

- Tighten down screw (1).

Alternator to holder

M10x125/M10x75		Tightening torque	38 Nm
----------------	--	-------------------	-------

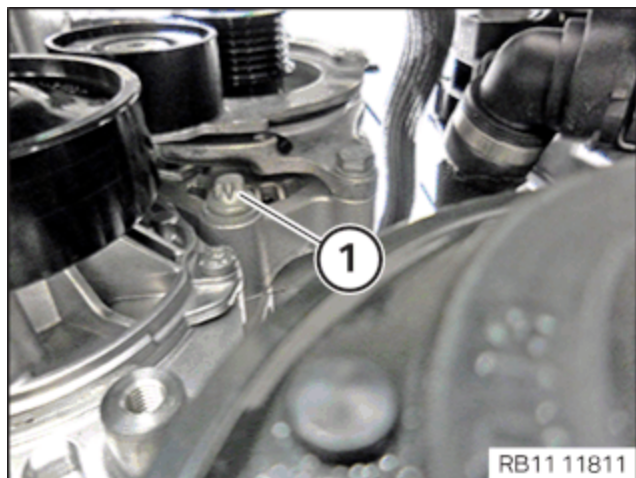

- Connect and lock the connector (3).
- Make sure the connector (3) engages audibly.
- Insert and install the positive battery cable (2) at the alternator.
- Tighten nut (1).

Positive battery cable to alternator

M8		Tightening torque	19 Nm
----	--	-------------------	-------

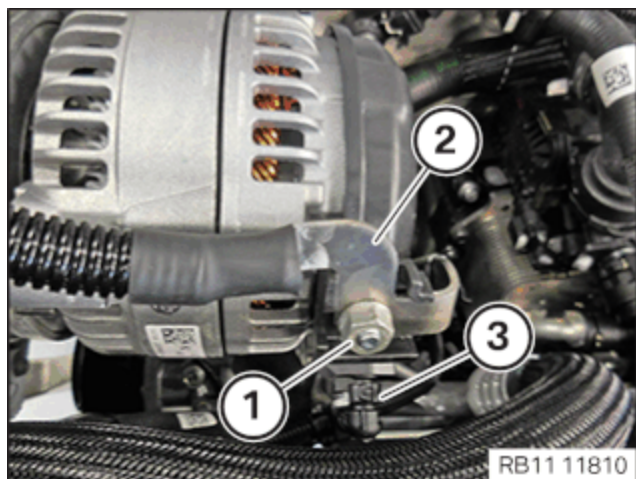

- Guide in and install cover (1).

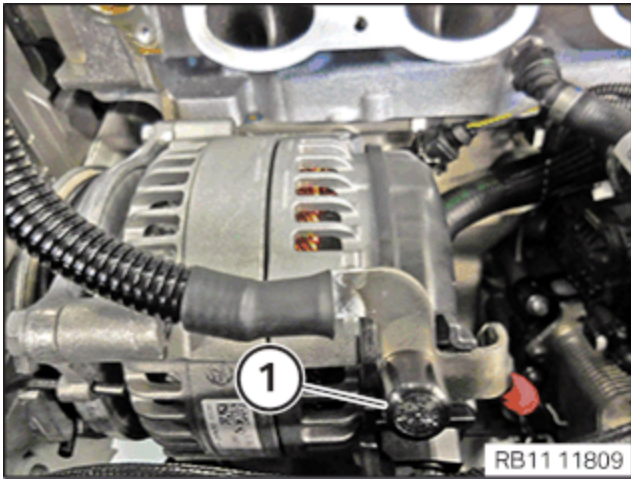

17 – Install drive belt



If the drive belt is reused: Mark direction of travel and reinstall drive belt in same direction of travel.



The drive belt must be replaced if contaminated with coolant- and oil residues.

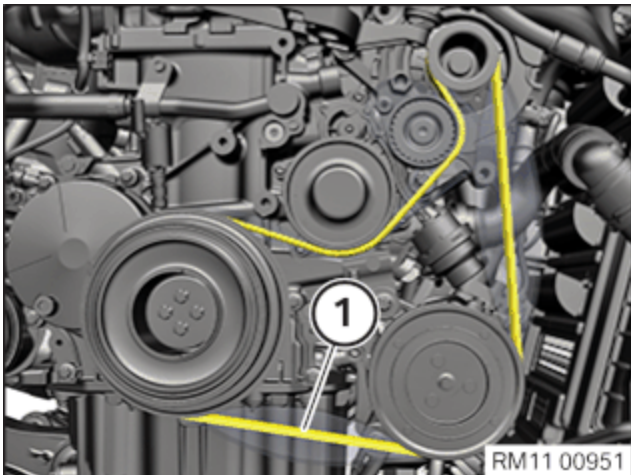

- Check the drive belt (1) for coolant residue and oil residue and renew as required.
- Fit the drive belts (1) on the ancillary component and the deflecting element as shown.
- Make sure the drive belt (1) is fitted correctly.

- Increase the pretension of the belt tensioner on the hexagon head (1) in the direction of arrow, till the special tool **0 496 268 (11 0 390)** can be removed.

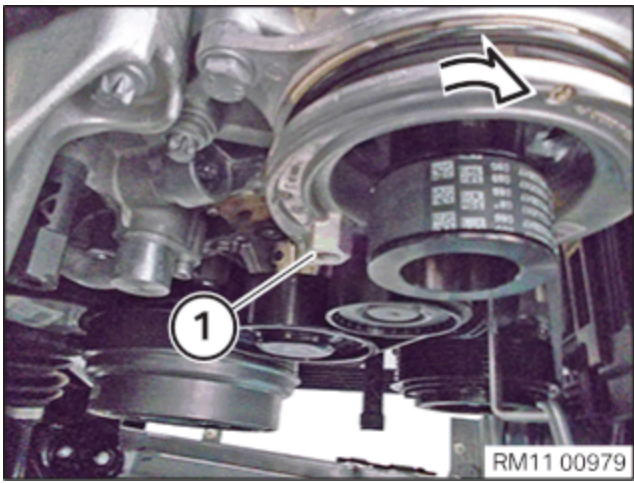

- Remove special tool **0 496 268 (11 0 390)** from belt tensioner.
- Stretch drive belt for alternator.

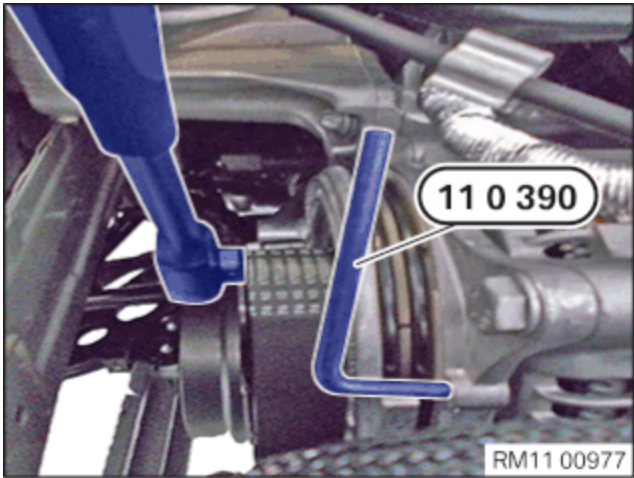

18 – If installed: Install the right brake air duct

- Feed in and position brake air duct (4) with the vertical strut (6).
- Tighten down screw (5).
- Tighten down screw (3).
- Tighten the screws (2).
- Tighten down screw (1).

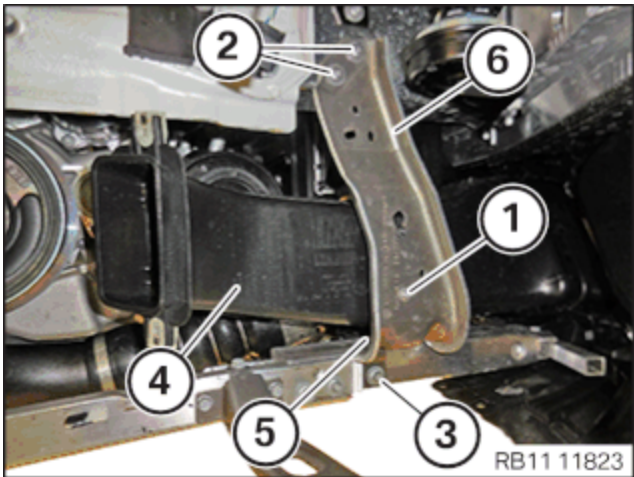

Brake air duct to bracket

Screw	Tightening torque
	4 Nm

19 – Installing washer fluid reservoir

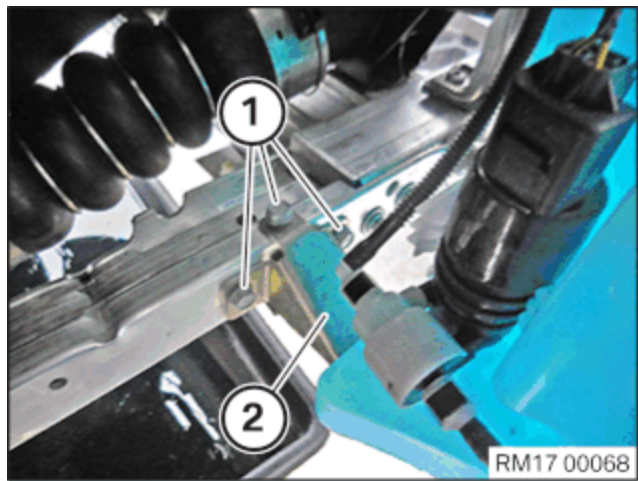

- Install the holder (2) for the washer fluid reservoir.
- Tighten the screws (1).

Washer fluid reservoir on front wall / adapter for front axle support

			8 Nm
--	--	--	------

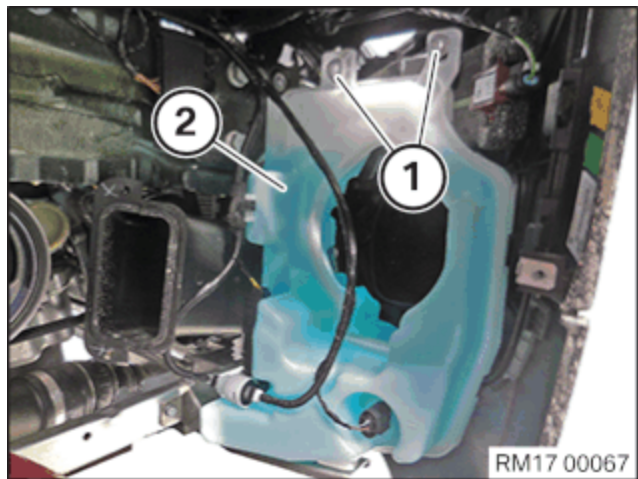

- Install the washer fluid reservoir (2).
- Tighten the screws (1).

Washer fluid reservoir on front wall / adapter for front axle support

			8 Nm
--	--	--	------

20 – Install front right wheel arch cover



Description is for left component only. Procedure on the right side is identical.

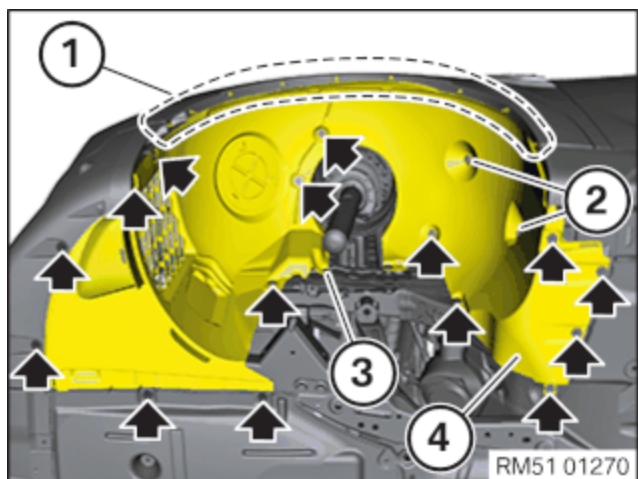

► Installing the front wheel arch cover

- Guide the wheel arch cover (4) in.
- Tighten screws (arrows).
- Tighten nuts (2).

Wheel arch cover

Screw		3 Nm
Plastic nut		2,6 Nm

- Attach the clip (3) and expanding rivets in area (1).

21 – Installing the front right wheel



Description is for left component only. Procedure on the right side is identical.



Schematic diagram is for example purposes. Some parts may differ in certain details.

► Mounting the wheel

▷ Clean the contact surfaces between the brake disc and the wheel rim

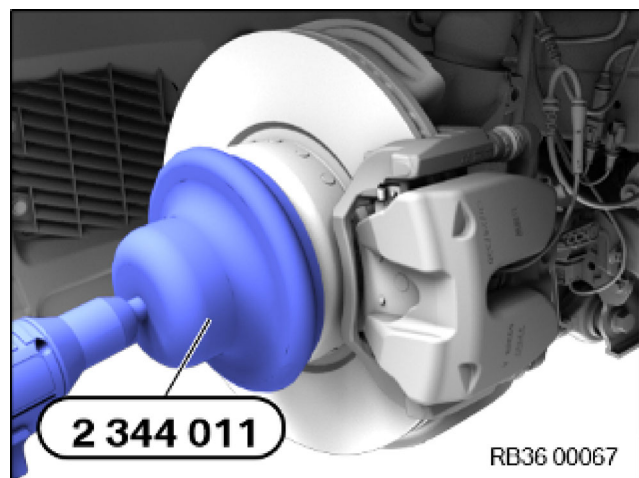

The contact surface between the brake disc and the wheel rim must be clean and free from oil and grease. There is otherwise a risk of the wheel becoming loose at a later time.

- Remove dirt, grease residues and corrosion from the contact surface with a drill and the special tool **2 344 011**.

Do not operate special tool **2 344 011** with an impact screwdriver.

- Degrease contact surfaces.

Expendable materials

Universal cleaner	20 l, Canister	83192360981
-------------------	-------------------	-------------

- If there are grease deposits in the area of the wheel bolt holes, remove and clean the brake disc.

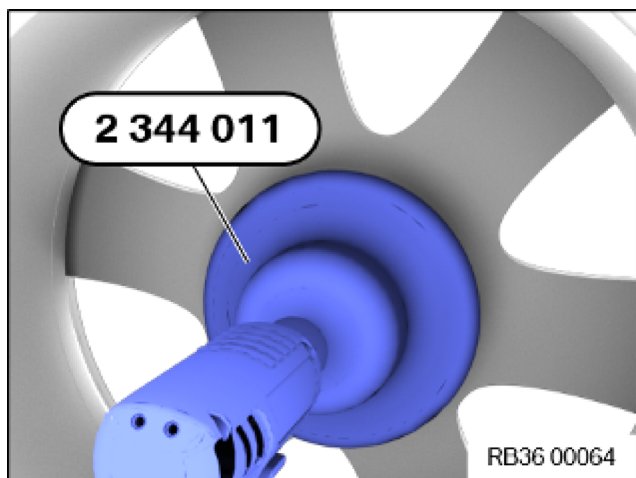

- Remove dirt, grease residues and corrosion from the contact surface with a drill and the special tool **2 344 011**.

Do not operate special tool **2 344 011** with an impact screwdriver.

- Degrease contact surfaces.

Expendable materials

Universal cleaner	20 l, Canister	83192360981
-------------------	-------------------	-------------

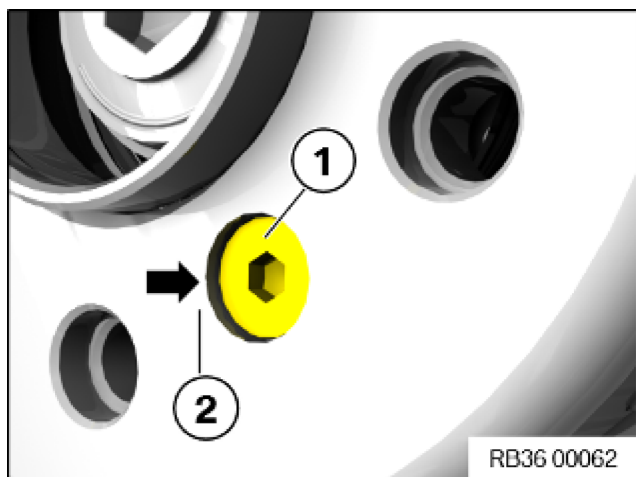

- Check that the mounting bolt (1) for the brake disc is securely seated.

The mounting bolt (1) for the brake disc **may not** protrude on the contact surface (2) (arrow) between the brake disc and the wheel rim.

Brake disc to front wheel hub

M8		Tightening torque	16 Nm
----	--	-------------------	-------

Brake disc to rear wheel hub

M8		Tightening torque	16 Nm
----	--	-------------------	-------

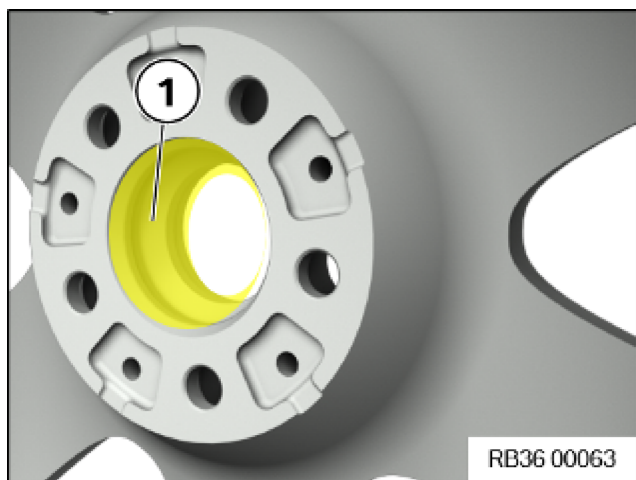

- Thinly grease the wheel centring (1) in the wheel rim.

Expendable materials

Brake block paste * TU = Trade Unit. TU numbers cannot be ordered! For invoicing purposes only.	3 g, Bag	83192158851
	100 g, Tube	83192158852
	5 g, TU*	83230140233

- Lightly grease the front and rear wheel hubs in this area (1) to protect from corrosion.

Expendable materials

Brake block paste * TU = Trade Unit. TU numbers cannot be ordered! For invoicing purposes only.	3 g, Bag	83192158851
	100 g, Tube	83192158852
	5 g, TU*	83230140233

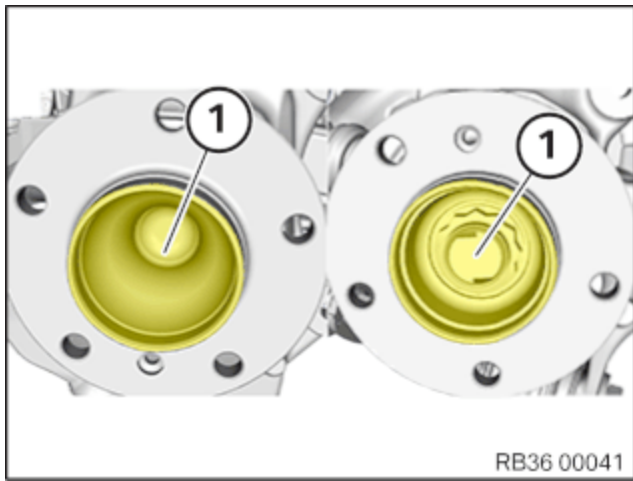

Check

- Check wheel bolts for wear.

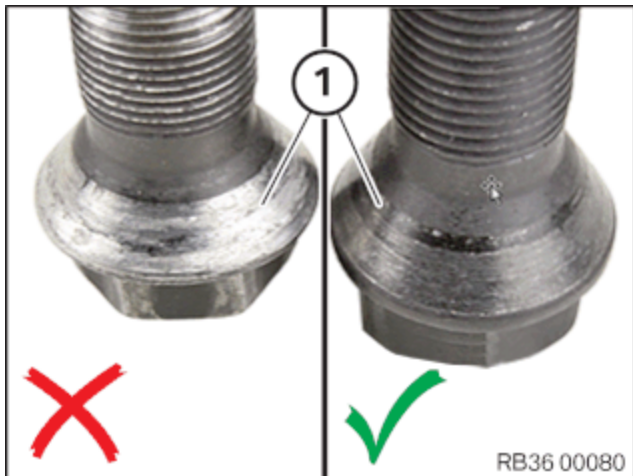

Result

- » Put (> 30%) of the bearing surface (1) of the cone that shows silver wear on the screw head.

Measure

- Replace wheel bolts.

Parts: Wheel bolts



Never use impact screwdrivers or electric screwdrivers to screw in and tighten the wheel bolts.

The wheel rim must rest uniformly against the brake disc.

In the case of non-original BMW wheel bolts/wheel rims, it may be necessary to retighten the wheel bolts on account of setting properties (refer to the documentation from the manufacturer).

Do not apply oil to new wheel bolts.

- Clean the wheel bolts (arrows).
- Check wheel bolts (arrows) and threads for damage, renew the wheel bolts if necessary.
- Renew corroded wheel bolts (arrows).

Parts: Wheel bolts

- Screw in wheel bolts (arrows) crosswise by hand and tighten hand-tight to centre the wheel rim.
- Use the torque wrench to tighten the wheel bolts (arrow) crosswise.
- Tighten all wheel bolts (arrow) crosswise again to check.

Wheel bolts

M14 / SW17	Screw in wheel bolts and evenly tighten crosswise by hand in order to centre the wheel rim.	Tightening torque	140 Nm
	Tighten wheel bolts to the prescribed tightening torque with a calibrated torque wrench in a crosswise sequence.	Check	140 Nm
	Check all the wheel bolts in the same order or retighten to the prescribed tightening torque again.		

22 – Installing the intake plenum

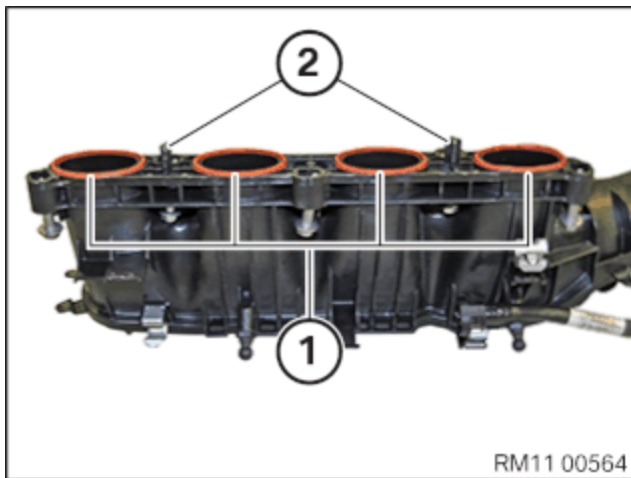

- Renew gaskets (1).

Parts: Seals

- Align the intake plenum according to the guides (2) on the cylinder head.

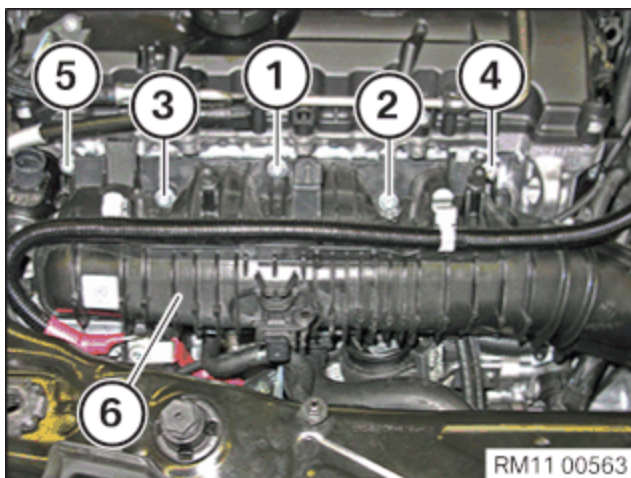

- Guide in and install intake plenum (6).
- Position the intake plenum (6).
- Apply the screws in the sequence (1), (2), (3), (4), (5).
- Tighten the screws in the sequence (1), (2), (3), (4), (5).

Intake plenum to cylinder head

Observe tightening sequence.

M6		Tightening torque	10 Nm
----	--	-------------------	-------

- Check seal (1) for damage and renew seal (1) as needed.

Parts: Gasket

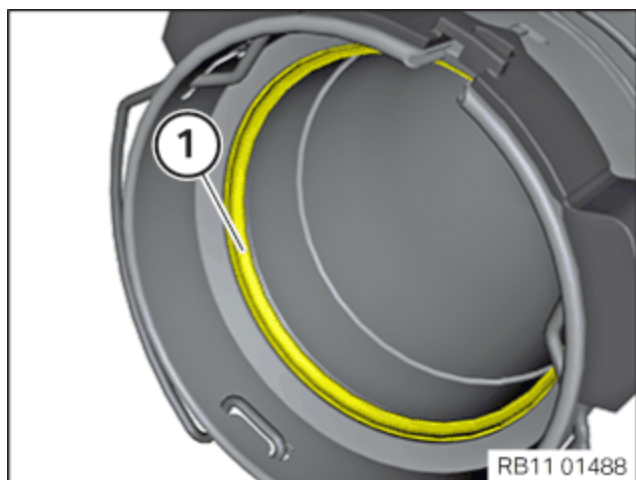

- Detach the locks (1) in the direction of the arrow from the brackets.

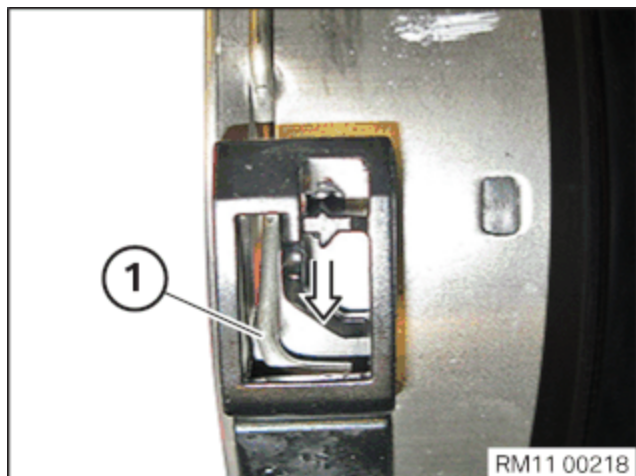

- Connect and lock the connector (1) on the charging pressure sensor.
- Connect and lock the connector (2) on the throttle valve.
- Make sure you can hear the connectors (1) and (2) engage.
- Connect the pressure pipe (3) on the throttle body and lock.
- Make sure the pressure pipe (3) engages audibly at the throttle body.

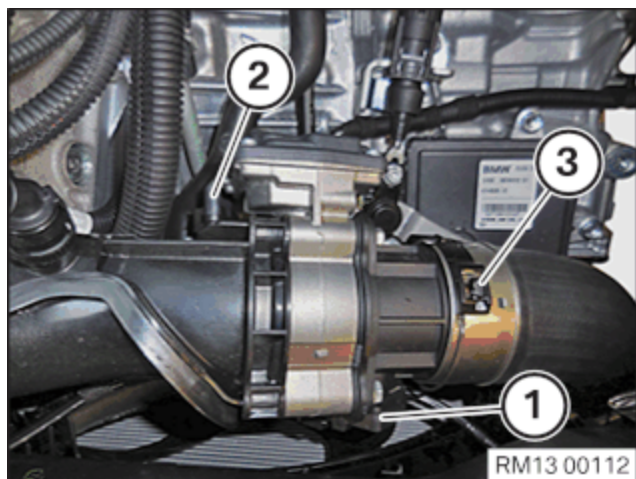

Replacing alternator drive belt tensioner

- Thread in cable channel (1) and install.
- Make sure that you can hear the locks (arrows) engage.

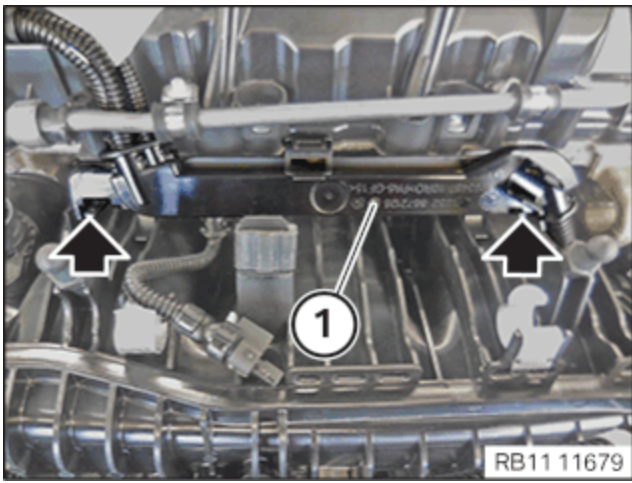

- Guide the fuel delivery line (2) in and install.
- Tighten the screws (1).

Fuel delivery line to cylinder head cover

M6x18		Tightening torque	7 Nm
-------	--	-------------------	------

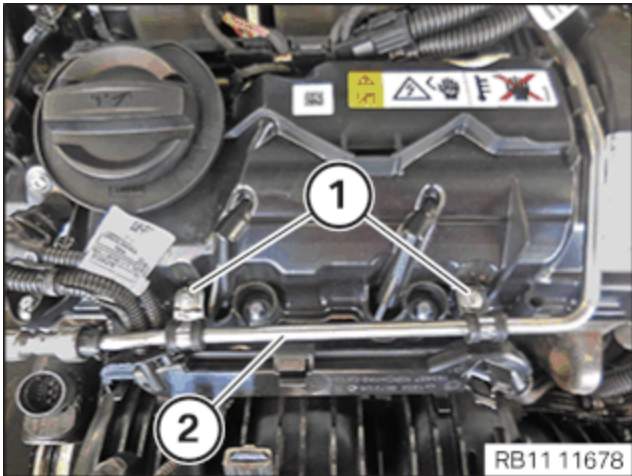

- Secure the coolant line (1) to the holder (2).

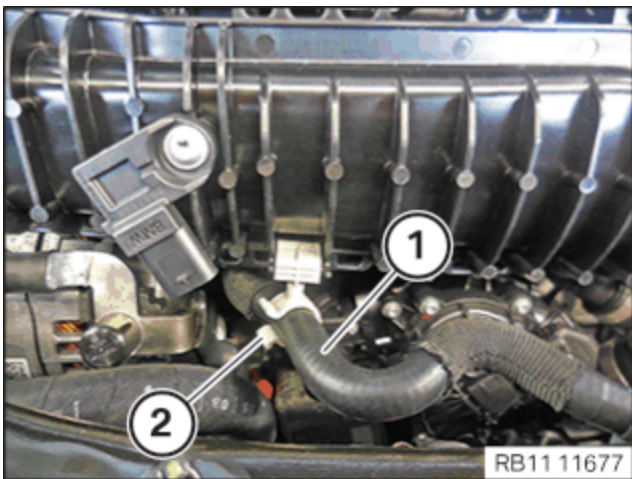

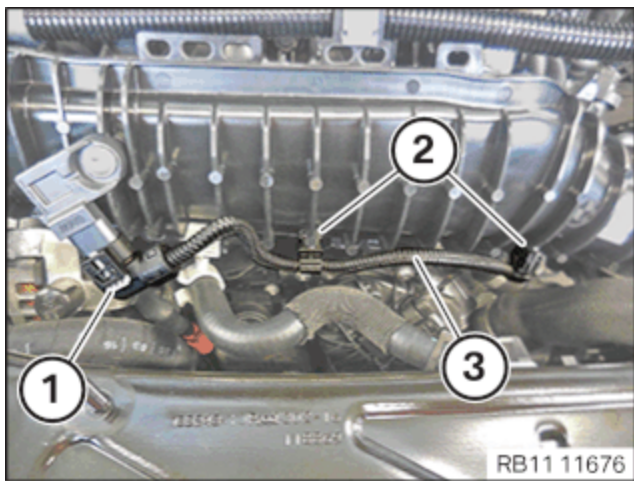

- Connect and lock the connector (1) on the charging pressure sensor.
- Make sure the connector (1) engages audibly at the charging pressure sensor.
- Insert and install the wiring harness (3).
- Secure clamps (2).

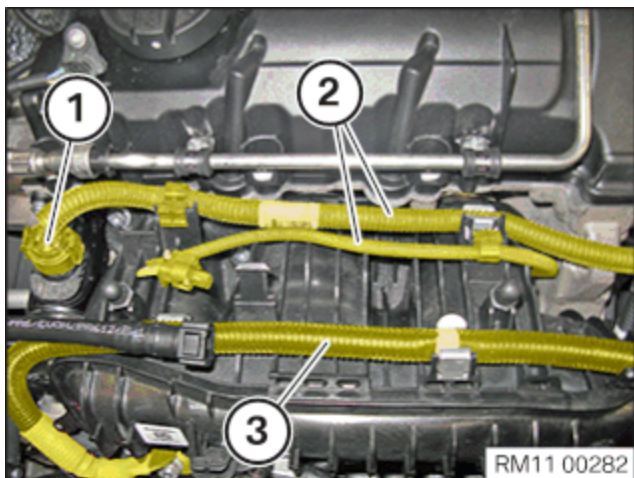

- Connect and lock the connector (1) on the VTC controller.
- Make sure the connector (1) engages audibly.
- Clip the wiring harness (2) into the intake plenum.
- Clip in the positive battery cable of the alternator (3) on the intake plenum.

23 – Installing servomotor for the eccentric shaft



Improper routing of cables and wiring harnesses.

Trapped, crushed or damaged cables may cause short circuits and malfunctions.

- Route all cables without abrasions, do not trap and crush.

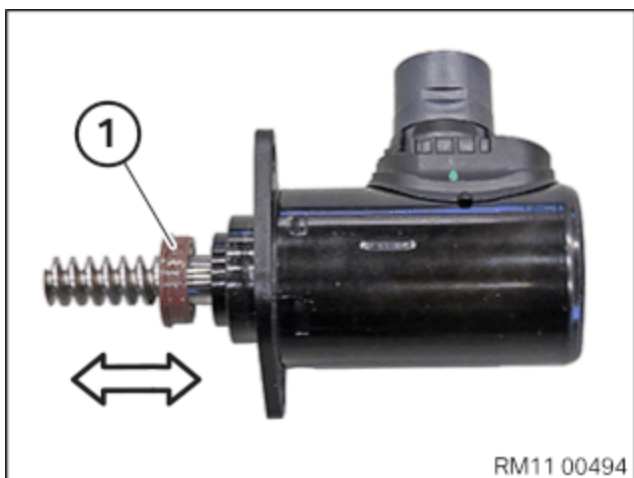

- Renew seal (1).

Parts: Gasket

- Press the seal (1) up to the limit position on the housing.

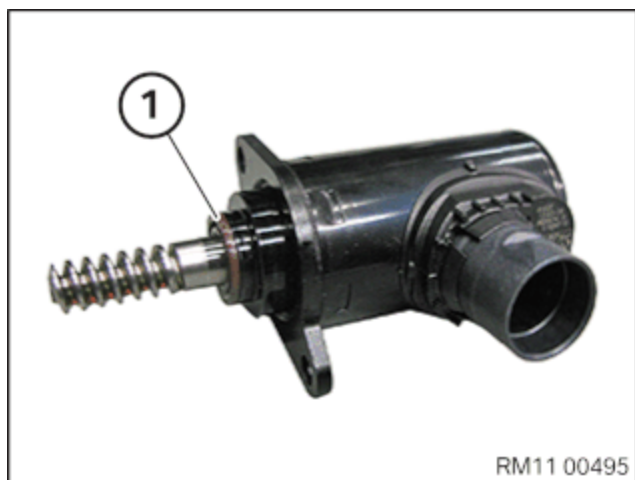

- Grease the gearing (1) of the servomotor for the eccentric shaft (2) in the **marked** area.

Parts: Lubricating grease

Expendable materials

lubricating grease Longtime PD -1	400 g, Cartridge	83192160340
--------------------------------------	---------------------	-------------

[Overview of consumables \(Electronic Parts Catalogue\)](#)

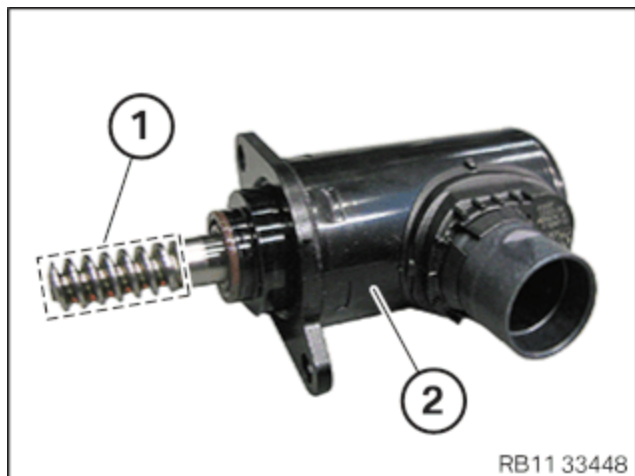

- Insert the servomotor (1) to the gearing on the cylinder head.
- Turn the drive shaft of the servomotor (1) in the direction of the arrow with a standard tool (2) until the servomotor (1) is flush with the cylinder head.

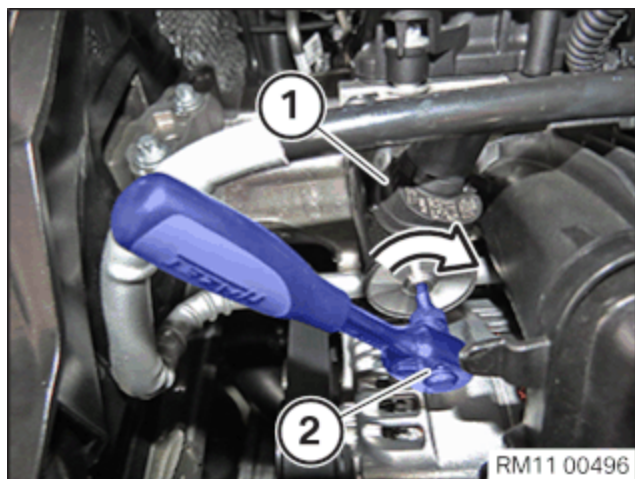

- Tighten the screws (1).

Electrical servomotor to cylinder head

M6		Tightening torque	8 Nm
----	--	-------------------	------

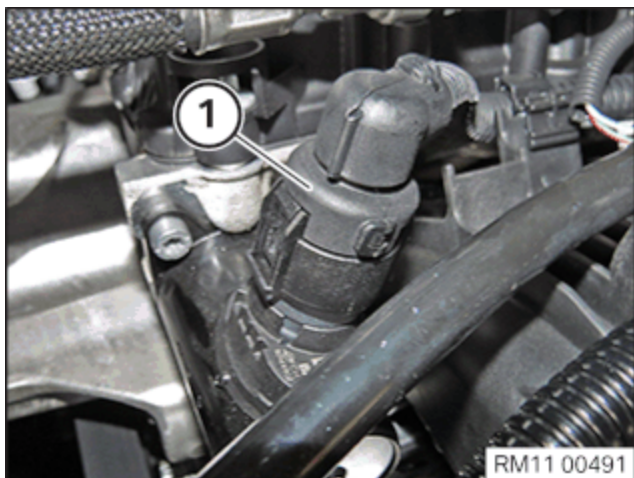
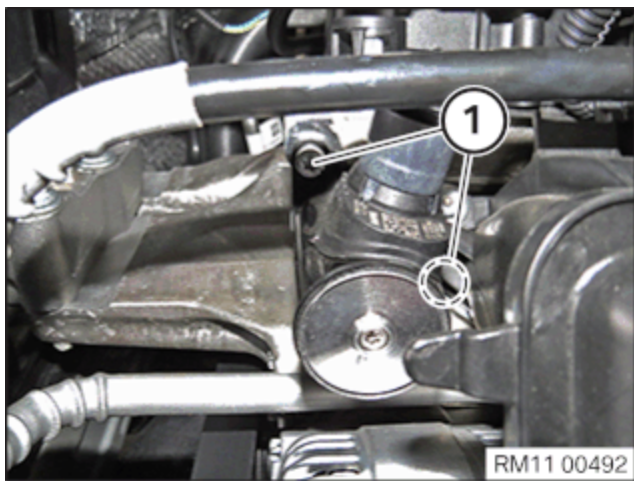

- Connect connectors (1) and lock.
The connector (1) must engage audibly.

24 – Installing the tank vent valve

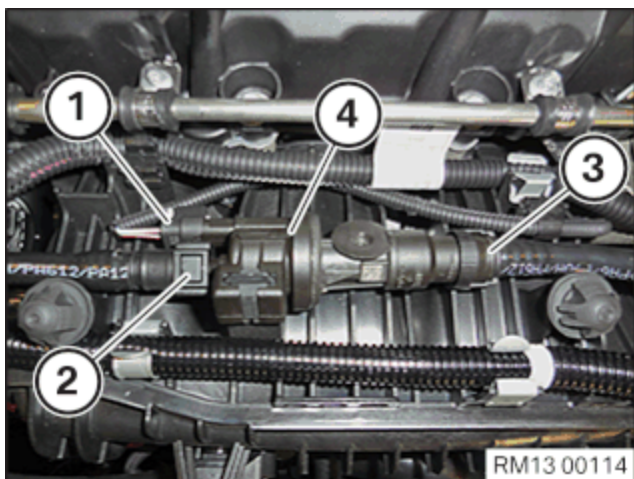

- **Version: A**
Connect connectors (1) and lock.
Connect the tank ventilation line (2).
Connect tank ventilation line (3).
The tank ventilation lines (2) and (3) must audibly engage.
Secure the tank vent valve (4) to the holder .

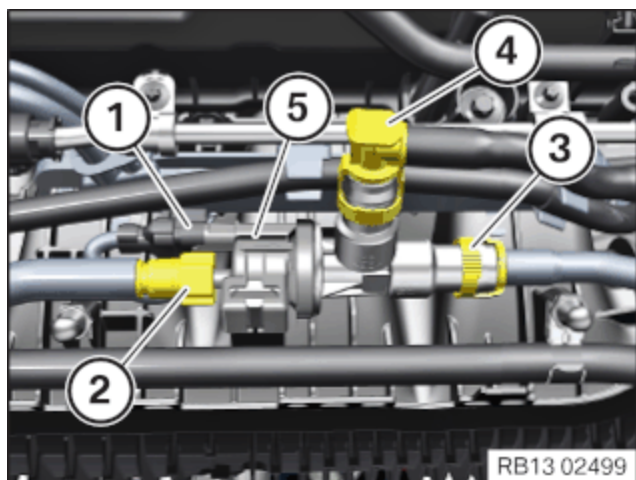

- **Version B**

Secure the tank vent valve (5) to the holder.

Connect the tank vent lines (2), (3) and (4).

The tank vent lines (2), (3) and (4) must audibly engage.

Connect connectors (1) and lock.

The connector (1) must engage audibly.

25 – Install cross connection

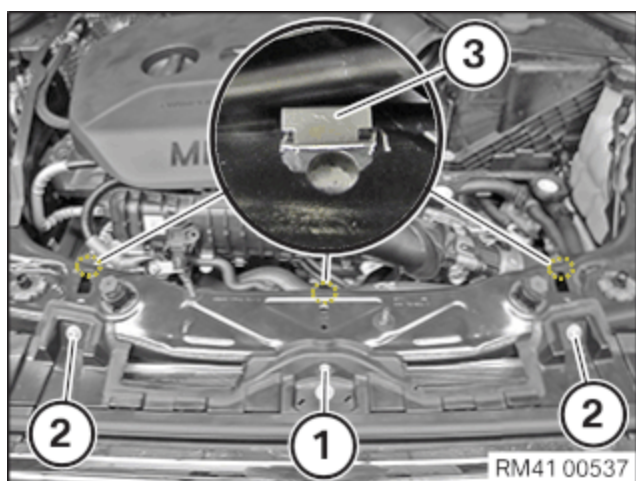

- Install cross connection.
- Position all screws.
- Tighten down screw (1).

Bracing strut to top cross connection

M8		Tightening torque	25 Nm
----	--	-------------------	-------

- Tighten the screws (2).

Air duct to deformation element/cross connection

M6x20 screw		Tightening torque	6 Nm
-------------	--	-------------------	------



Incorrect routing of the Bowden cable for the bonnet lock.

Abrasion of the coolant ventilation line, coolant loss and engine overheating.

- Route the Bowden cable of the bonnet lock correctly under the lock bridge.
 - Hook the Bowden cable to all the clips.
 - Make sure that the Bowden cable has no contact with the coolant ventilation line.
- Fasten clamps (3) for bonnet lock Bowden cable to cross connection.

- Tighten screws (2) on the cross connection (3).

Cross connection on support for cross connection

M6x20		Tightening torque	12 Nm
-------	--	-------------------	-------

- If necessary, fasten expanding rivet (1).

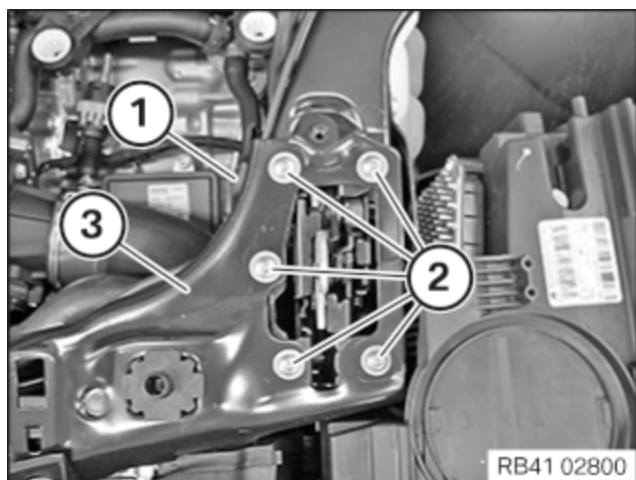

- Tighten the screws (2).

Cross connection on support for cross connection

M6x20		Tightening torque	12 Nm
-------	--	-------------------	-------

- Fasten expanding rivet (1).

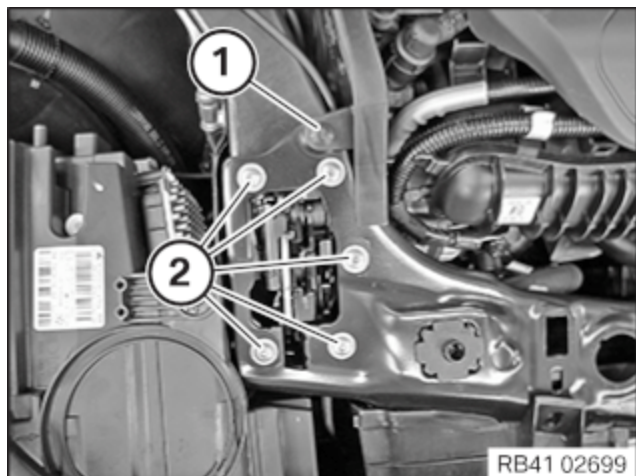

- **Installed on the right side only on vehicles with production date as of: 12/2016**
- Secure spray guard (1) on the cross connection (2) as pictured.
- Secure spray guard (1) to the bridge with retaining tabs (3).
- Properly mount spray guard (1) to prevent corrosion.

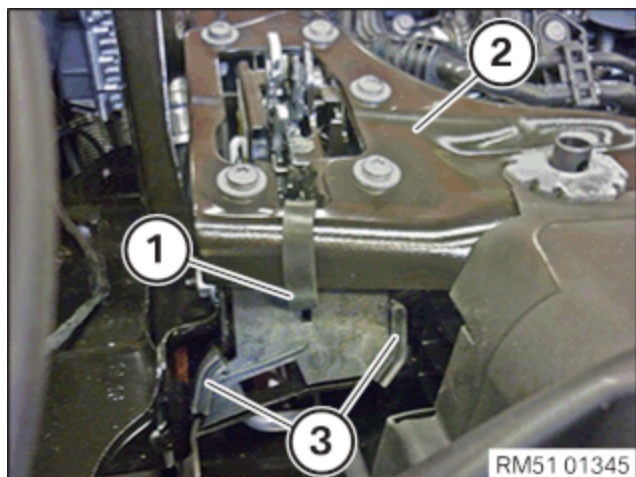

26 – Installing intake silencer housing

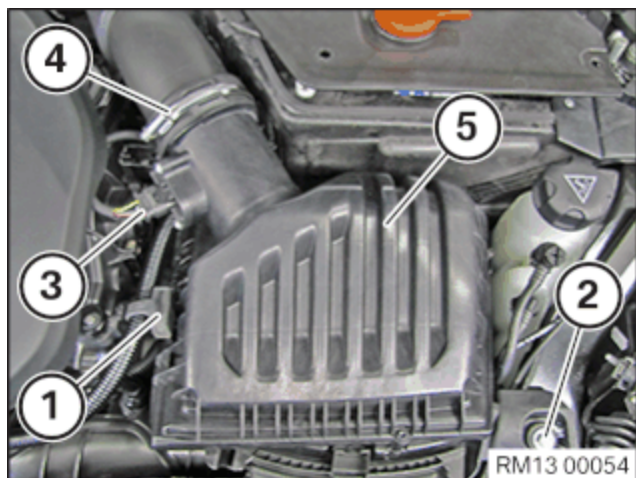

- Insert intake filter housing (5) in rubber mount.
- Slide clean air pipe onto the intake filter housing.
- Tighten clamp (4).

Intake filter housing to clean-air pipe

Clamp		Tightening torque	3 Nm
-------	--	-------------------	------

- Connect connector (3) to the hot film air mass meter and lock it audibly.
- Tighten down screw (2).

Intake filter housing to cross connection

M6			8 Nm
----	--	--	------

- Mount rubber retainer (1) on the intake filter housing.

27 – Installing intake port

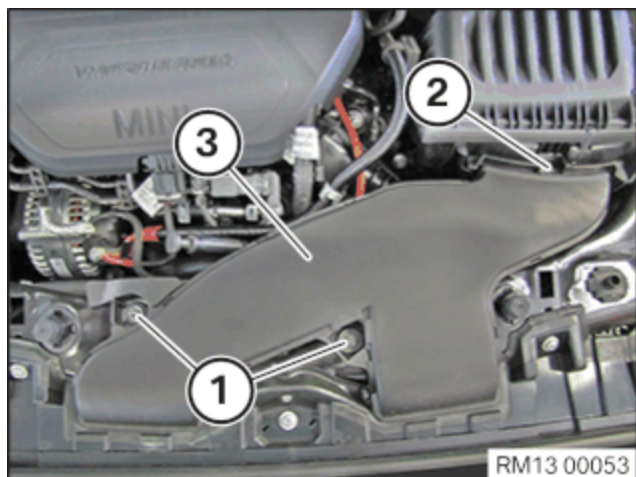

- Feed in intake port (3) and install.
- Lock the lock (2).
- Tighten nuts (1).

Intake port on cross connection

M6 hexagon nut		Tightening torque	8 Nm
----------------	--	-------------------	------

28 – Install acoustic cover



Damage to the acoustic cover/design cover.

Jerky movements during disassembly and excessive application of force during installation may result in breakage of the acoustic cover/design cover.

- Disassemble or mount the acoustic cover/design cover carefully.
- Disassemble or mount snap-lock couplings of the ball pivots one after the other.
- Disassemble or mount acoustic cover/design cover only at temperatures $>20\text{ }^{\circ}\text{C}$.
- Use only distilled water as an auxiliary material during installation, no lubricants.

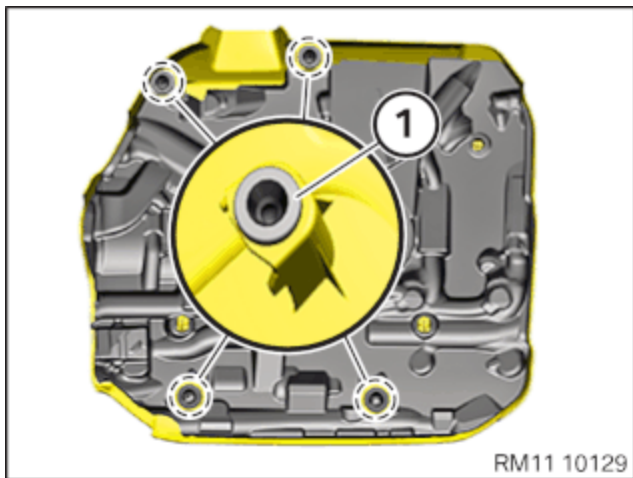

- Check for correct installation of all rubber mounts in the acoustic cover (1).

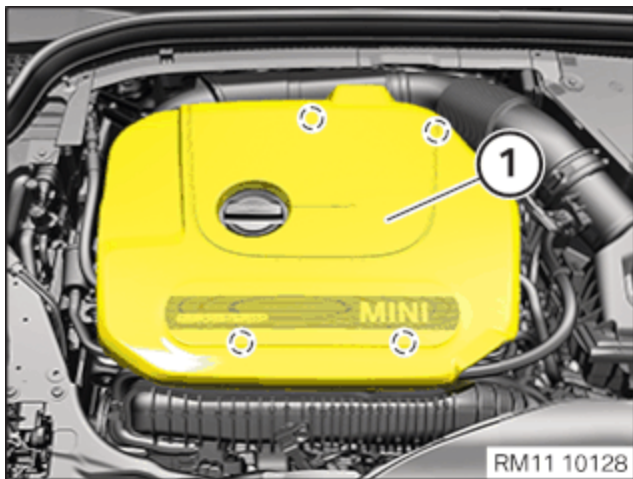

- Clip in the acoustic cover (1) into the holders in the indicated areas.
- Make sure that the acoustic cover (1) engages audibly.

29 – Connecting all battery earth leads



- See additional information.

Additional Information

Overview of Tightening Torques

Belt tensioner to alternator			Used in step 15
M8x30		Tightening torque	28 Nm
Alternator to holder			Used in step 16
M10x125/M10x75		Tightening torque	38 Nm
Positive battery cable to alternator			Used in step 16
M8		Tightening torque	19 Nm
Brake air duct to bracket			Used in step 18
Screw		Tightening torque	4 Nm
Washer fluid reservoir on front wall / adapter for front axle support			Used in step 19
			8 Nm
Wheel arch cover			Used in step 20
Screw			3 Nm
Plastic nut			2,6 Nm
Brake disc to front wheel hub			Used in step 21
M8		Tightening torque	16 Nm
Brake disc to rear wheel hub			Used in step 21
M8		Tightening torque	16 Nm

Wheel boltsUsed in step [21](#)

M14 / SW17	Screw in wheel bolts and evenly tighten crosswise by hand in order to centre the wheel rim. Tighten wheel bolts to the prescribed tightening torque with a calibrated torque wrench in a crosswise sequence. Check all the wheel bolts in the same order or retighten to the prescribed tightening torque again.	Tightening torque	140 Nm
		Check	140 Nm

Intake plenum to cylinder headUsed in step [22](#)

Observe tightening sequence.

M6		Tightening torque	10 Nm
----	--	-------------------	-------

Fuel delivery line to cylinder head coverUsed in step [22](#)

M6x18		Tightening torque	7 Nm
-------	--	-------------------	------

Electrical servomotor to cylinder headUsed in step [23](#)

M6		Tightening torque	8 Nm
----	--	-------------------	------

Bracing strut to top cross connectionUsed in step [25](#)

M8		Tightening torque	25 Nm
----	--	-------------------	-------

Air duct to deformation element/cross connectionUsed in step [25](#)

M6x20 screw		Tightening torque	6 Nm
-------------	--	-------------------	------

Cross connection on support for cross connectionUsed in step [25](#)

M6x20		Tightening torque	12 Nm
-------	--	-------------------	-------

Intake filter housing to clean-air pipeUsed in step [26](#)

Clamp		Tightening torque	3 Nm
-------	--	-------------------	------

Intake filter housing to cross connectionUsed in step [26](#)

M6			8 Nm
----	--	--	------

Intake port on cross connectionUsed in step [27](#)

M6 hexagon nut		Tightening torque	8 Nm
----------------	--	-------------------	------

Overview of Special Tools

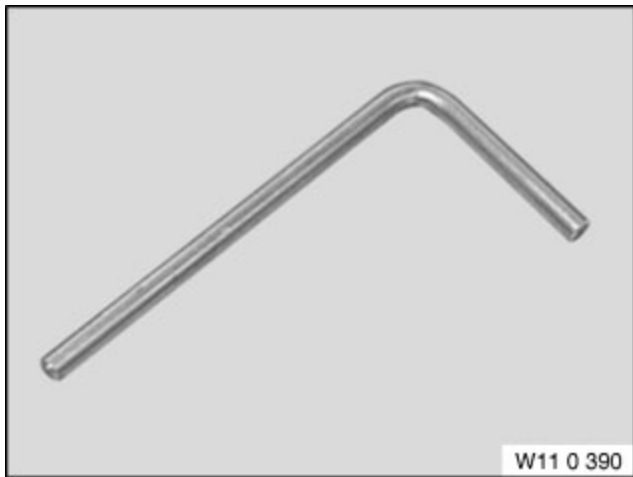
0 496 268 (11 0 390) Pin**Common**Used in step [13](#) [17](#)

Usage (roll pin) For securing new tensioning pulley (poly-V belt)

Included in the tool or work

Storage location B24

Replaced by

In connection with

SI-Number 01 15 07 (390)

2 344 011 Tool**Common**Used in step [21](#)

Usage Tool (wheel hub grinder) for cleaning the connection of the wheel rim (wheel contact face) to the wheel hub.

Included in the tool or work

Storage location

Replaced by

In connection with

SI-Number 08 08 12 (872)

Replacement tools:

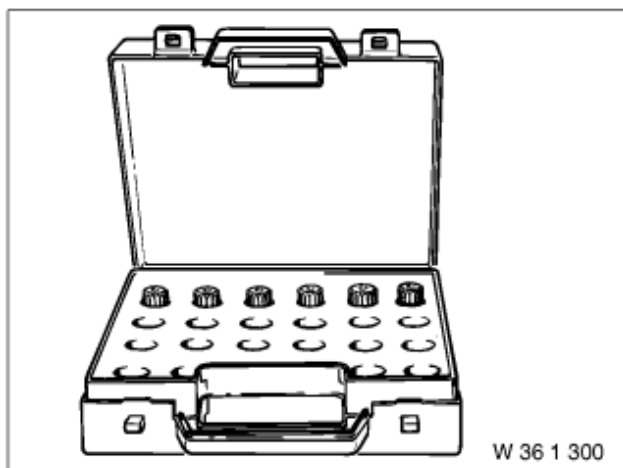
0 495 221 (36 1 323) Wheel stud**Common**Used in step **9**

Usage (Code 30) Code 39 available separately, (see EPC) under 36 13 1 181 259

Included in the tool or work 0 492 518

Storage location

Replaced by

In connection with

SI-Number

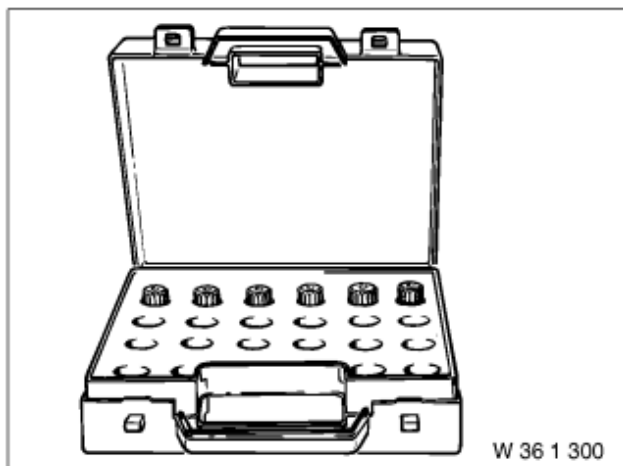
0 495 224 (36 1 326) Wheel stud**Common**Used in step **9**

Usage (Code 33) With centring bore available separately, (see EPC) under 36 13 6 765 546

Included in the tool or work 0 492 518

Storage location

Replaced by

In connection with

SI-Number

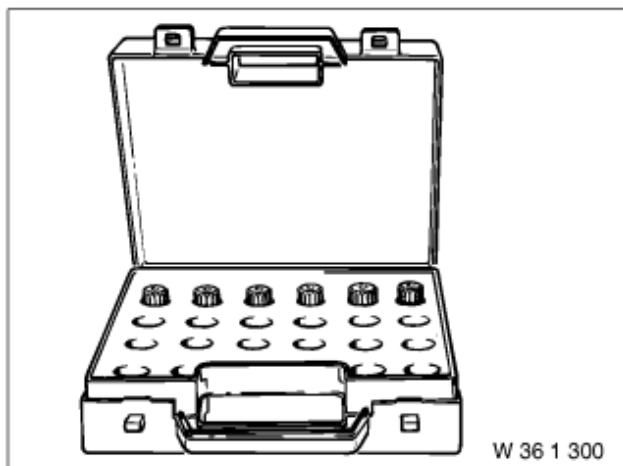
0 495 225 (36 1 327) Wheel stud**Common**Used in step **9**

Usage (Code 34) With centring bore available separately (see EPC) under 36 13 6 765 547

Included in the tool or work 0 492 518

Storage location

Replaced by

In connection
with

SI-Number

Common

Used in step [9](#)

Usage

(Code 35) With centring bore available separately, (see EPC) under 36 13 6 762 340

Included in
the tool or
work

0 492 518

Storage
location

Replaced by

In connection
with

SI-Number

0 495 226 (36 1 328) Wheel stud

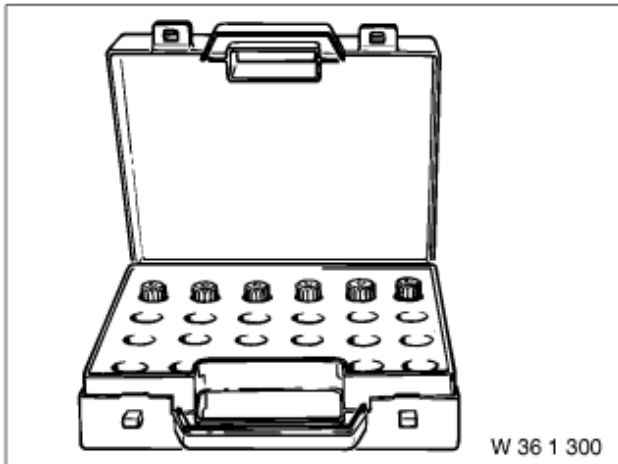

0 495 227 (36 1 329) Wheel stud

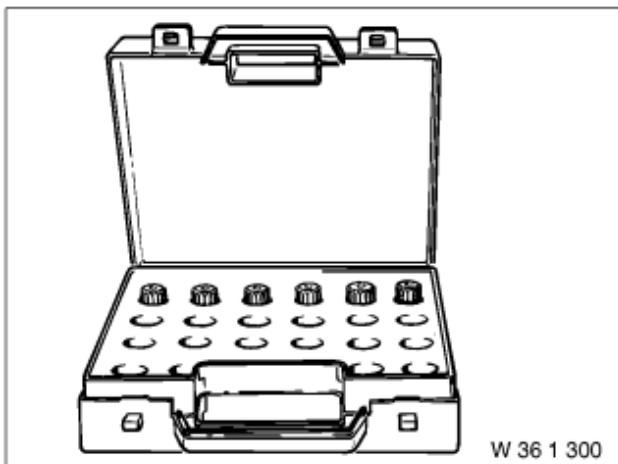

Common

Used in step [9](#)

Usage

(Code 36) With centring bore available separately (see EPC) under 36 13 6 762 341

Included in
the tool or
work

0 492 518

Storage
location

Replaced by

In connection
with

SI-Number

0 495 228 (36 1 331) Wheel stud

Used in step [9](#)

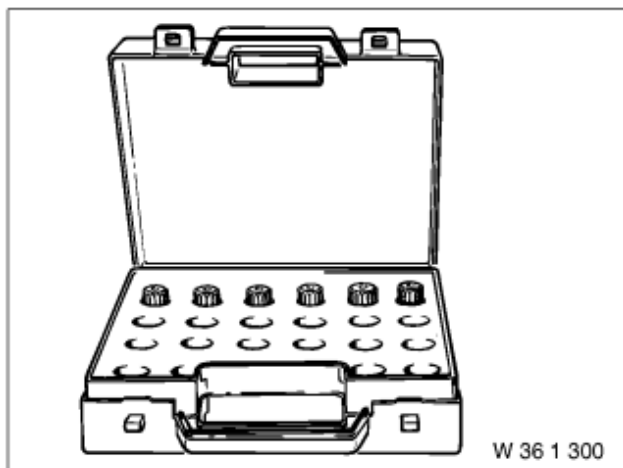
**Common**

Usage (Code 37) With centring bore available separately (see EPC) under 36 13 6 762 342

Included in the tool or work 0 492 518

Storage location

Replaced by

In connection with

SI-Number

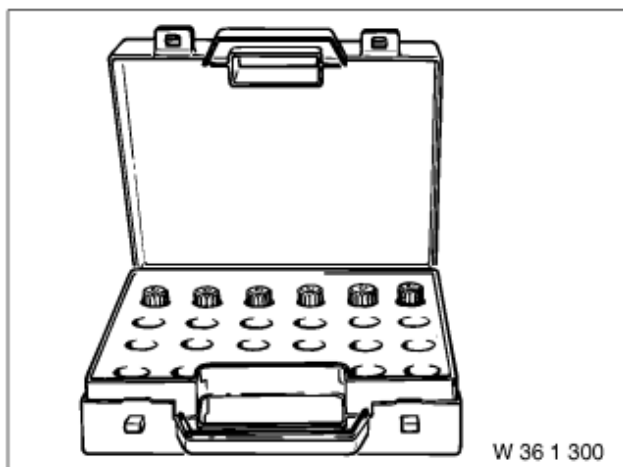
0 495 229 (36 1 332) Wheel stud**Common**Used in step **9**

Usage (Code 38) With centring bore available separately (see EPC) under 36 13 6 762 343

Included in the tool or work 0 492 518

Storage location

Replaced by

In connection with

SI-Number

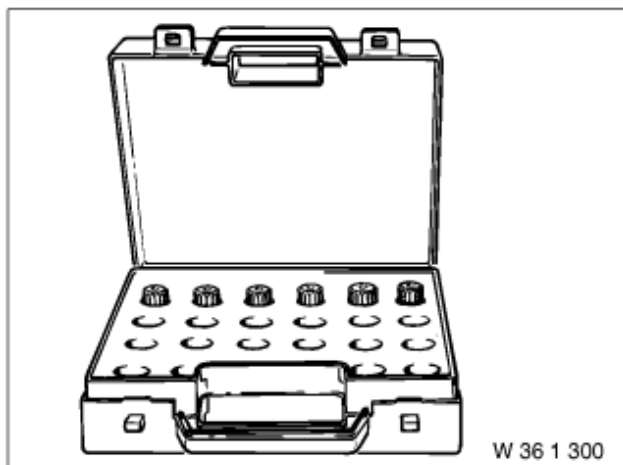
0 495 230 (36 1 333) Wheel stud**Common**Used in step **9**

Usage (Code 40) With centring bore available separately (see EPC) under 36 13 6 762 344

Included in the tool or work 0 492 518

Storage location

Replaced by

In connection with

SI-Number

Links

Repair instructions (PRE)	Used in step
---------------------------	--------------

Safety information for handling electric and hybrid vehicles	5 25
--	------

General repair instructions	Used in step
-----------------------------	--------------

Repair instructions	Used in step
---------------------	--------------

61 20 900 Disconnecting and connecting the battery earth lead (all battery earth leads)	1 29
---	------

61 20 900 Disconnecting and connecting battery earth lead	1 29
---	------

61 20 900 Disconnecting and connecting battery earth lead	1 29
---	------

61 20 900 Disconnecting and connecting battery earth lead	1 29
---	------

61 20 900 Disconnecting and connecting battery earth lead	1 29
---	------

61 20 900 Disconnecting and connecting battery earth lead	1 29
---	------

61 20 900 Disconnecting and connecting battery earth lead	1 29
---	------

61 20 900 Disconnecting and connecting the battery earth lead (all battery earth leads)	1 29
---	------

61 20 900 Disconnecting and connecting the battery earth lead (all battery earth leads)	1 29
---	------

61 20 900 Disconnecting and connecting the battery earth lead (all battery earth leads)	1 29
---	------

61 20 900 Disconnecting and connecting battery earth lead	1 29
---	------

61 20 900 Disconnecting and connecting battery earth lead	1 29
---	------

61 20 900 Disconnecting and connecting the battery earth lead (all battery earth leads)	1 29
---	------

61 20 900 Disconnecting and connecting battery earth lead	1 29
---	------

61 20 900 Disconnecting and connecting battery earth lead	1 29
---	------

61 20 900 Disconnecting and connecting battery earth lead	1 29
---	------

61 20 900 Disconnecting and connecting battery earth lead	1 29
---	------

61 20 900 Disconnecting and connecting battery earth lead	1 29
---	------

61 20 900 Disconnecting and connecting battery earth lead	1 29
---	------

61 20 900 Disconnecting and connecting battery earth lead	1 29
---	------

61 20 900 Disconnecting and connecting battery earth lead	1 29
---	------

61 20 900 Disconnecting and connecting the battery earth lead (all battery earth leads)	1 29
---	------

61 20 900 Disconnecting and connecting the battery earth lead (all battery earth leads)	1 29
---	------

61 20 900 Disconnecting and connecting battery earth lead	1 29
---	------

61 20 900 Disconnecting and connecting the battery earth lead (all battery earth leads)	1 29
---	------

61 20 900 Disconnecting and connecting battery earth lead (Plug-in Hybrid Electric Vehicle)	1	29
61 20 900 Disconnecting and connecting battery earth lead	1	29
61 20 900 Disconnecting and connecting battery earth lead	1	29
61 20 900 Disconnecting and connecting battery earth lead	1	29
61 20 900 Disconnecting and connecting battery earth lead	1	29
61 20 900 Disconnecting and connecting battery earth lead	1	29
61 20 900 Disconnecting and connecting battery earth lead	1	29
61 20 900 Disconnecting and connecting battery earth lead	1	29
61 20 900 Disconnecting and connecting battery earth lead	1	29
61 20 900 Disconnecting and connecting battery earth lead	1	29
61 20 900 Disconnecting and connecting battery earth lead	1	29
61 20 900 Disconnecting and connecting battery earth lead	1	29
61 20 900 Disconnecting and connecting battery earth lead	1	29
61 20 900 Disconnecting and connecting battery earth lead	1	29
61 20 900 Disconnecting and connecting battery earth lead	1	29
61 20 900 Disconnecting and connecting battery earth lead	1	29
61 20 900 Disconnecting and connecting battery earth lead	1	29
61 20 900 Disconnecting and connecting the battery earth lead (all battery earth leads)	1	29
61 20 900 Disconnecting and connecting battery earth lead	1	29
61 20 900 Disconnecting and connecting battery earth lead	1	29
61 20 900 Disconnecting and connecting battery earth lead	1	29
61 35 ... Notes on ESD protection (Electro Static Discharge)	7	14 16
61 35 ... Notes on ESD protection (Electro Static Discharge)	7	14

Parts

Parts required

Designation	Used in step
4 x Seal for the intake plenum	22
1 x Sealing ring for servomotor	23

For informational purposes only. The information on this website is provided AS-IS with no warranties, express or implied, and is not guaranteed to be error-free, up-to-date or complete. NewTIS and BMW assume no liability for any loss or damage arising from the use or reliance on the information and content on this website. The content on this website is subject to change without notice.