

ORIGINAL MINI ACCESSORIES. INSTALLATION INSTRUCTIONS.



Removable trailer tow hitch retrofit.

MINI CLUBMAN (F54)
MINI Countryman (F60)

Retrofit kit number

71 60 2 245 628	Electrical components retrofit kit
71 60 6 875 020	Trailer tow hitch with removable ball (F54)
71 60 6 885 352	Trailer tow hitch with removable ball (F60)

Installation time

The installation time is **approx. 3.0 hours**. This may vary depending on the condition of the vehicle and the equipment in it.

If the fan frame needs to be replaced with the fan, the installation time increases by **approx. 1.0 hour**.

The installation time shown does not include any time spent on programming/coding.

The calculation of the total costs for the programming time must be factored into the calculation of retrofitting costs (no invoicing via warranty).

Important information

These installation instructions are primarily designed for use within the MINI dealership organisation and by authorised MINI service companies.

In any event the target group for these installation instructions is specialist personnel trained on MINI cars with the appropriate specialist knowledge.

All work must be completed using the latest MINI repair manuals, wiring diagrams, servicing manuals and work instructions, in a rational order, using the prescribed tools (special tools) and observing current health and safety regulations.

If you experience installation or function problems, restrict troubleshooting to approx. 0.5 hours for mechanical work and 1.0 hour for electrical work.

To avoid unnecessary extra work and/or costs, send an inquiry straight away to the technical parts support team via the Aftersales Assistance Portal (ASAP).

Quote the following information:

- Chassis number,
- Retrofit kit part number,
- A detailed description of the problem,
- Any work already carried out.

Do not archive the hard copy of these installation instructions since daily updates are provided via ASAP.

Pictograms

 Denotes instructions that draw your attention to dangers.

 Denotes instructions that draw your attention to special features.

◀ Denotes the end of the instruction or other text.

Legal requirements

For F54 cars only

- There is a type approval for the trailer tow hitch pursuant to **ECE-R55** with approval reference **E11*55R-110240**.

For F60 cars only

- There is a type approval for the trailer tow hitch pursuant to **ECE-R55** with approval reference **E11*55R-0110793**.

 These installation instructions also serve as installation confirmation. They must be printed and attached to the vehicle documents and kept in the car at all times until the trailer tow hitch has been entered in the vehicle documents. ◀

Installation information

Ensure that the cables and/or lines are not kinked or damaged as you install them in the car. Costs arising from this will not be reimbursed by BMW AG.

Additional cables/wires that you install must be secured with cable ties. If the specified PIN chambers are occupied, bridges, double crimps, or twin-lead terminals must be used.

All pictures show LHD (left-hand drive) cars; proceed accordingly on RHD (right-hand drive) cars.

After the installation work, the retrofit must be programmed / coded via the – **Conversions** – path.

 The black band will need to be replaced on various cars. As per EPC HG 51 ... ◀

 The fan cowl and fan will need to be replaced on various cars. If you do not replace the electric fan, the towing capacity will be reduced and the engine may stop. ◀

 On cars with Comfort access (SA 322), the Smart Opener function is disabled and the components (aerial with carrier and Smart Opener control unit) must be removed. ◀

Ordering instructions

The following parts are not supplied in the retrofit kit and must be ordered separately (see EPC for part number and details):

- Heat insulation **C** (not with SA 322)
- AAG control unit **I**
- Mini 5 A fuse **J** (3 x)
- Retrofitting the bus interface **L** (only for cars without bus interface already installed)
- ATO 20 A fuse **Q** (3 x)
- Fuse holder **R**
- Fan frame with fan **S** (see EPC HG 17)

Special tools required

Refer to the relevant ISTA/AIR repair manual for details of the special tool required.

Section	Page
1. Parts list for retrofit kit	4
2. Preparatory work	5
3. Retrofit wiring harness connection diagram	6
4. Bus interface retrofit wiring harness connection diagram	7
5. Installation and cabling diagram for LHD (left-hand drive) cars	8
6. Installation and cabling diagram for RHD (right-hand drive) cars	9
7. Retrofitting the bus interface (only for cars without bus interface already installed)	10
8. Installing the trailer tow hitch	11
9. Routing and connecting the retrofit wiring harness	13
10. Fitting the oddments tray	16
11. Concluding work and coding	17
12. Wiring diagram	18
13. Coupling ball clearances and installation height for towing ball coupling	20
14. Customer information	21

1. Parts list for retrofit kit

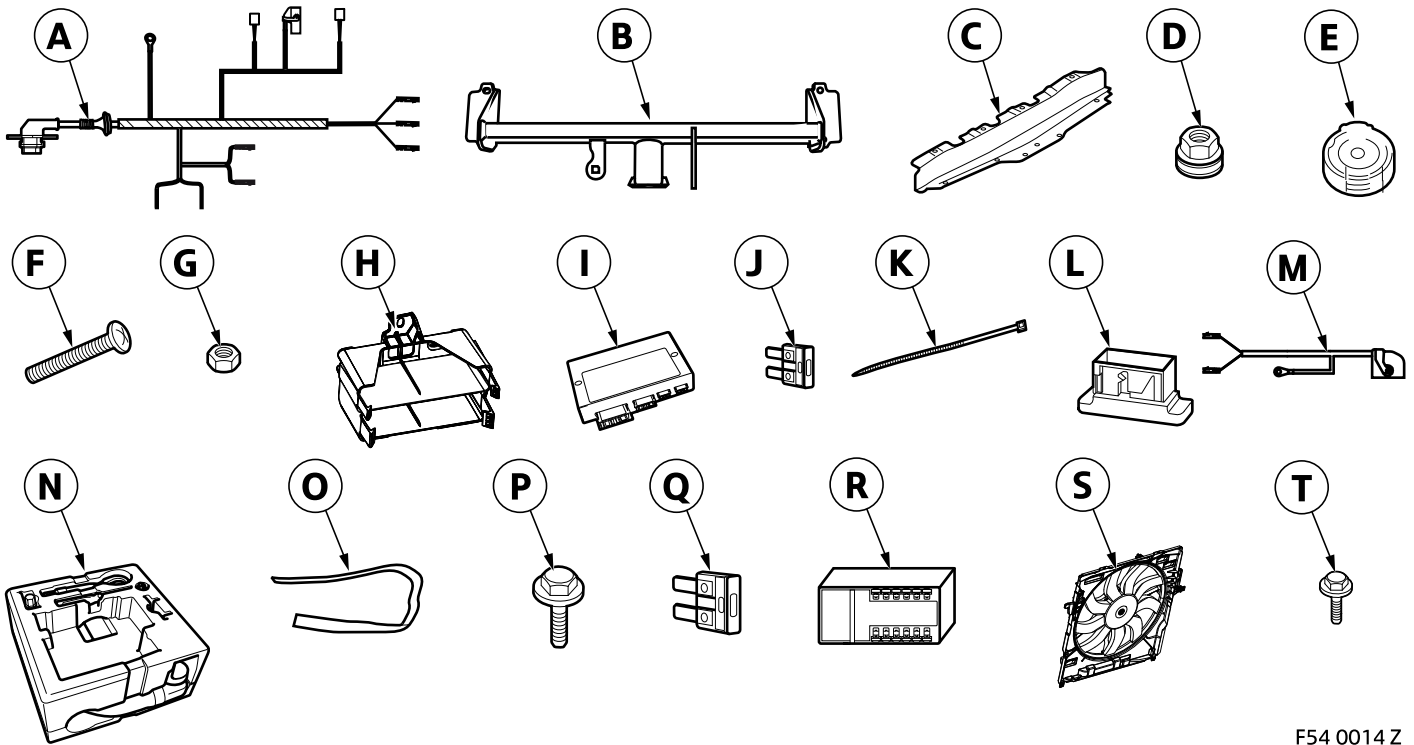

F54 0014 Z

Legend

- A** Retrofit wiring harness
- B** Trailer tow hitch
- C** Heat insulation (not supplied with the retrofit kit)
- D** M12 hexagon nut (4 x)
- E** Socket
- F** M5 pan-head screw (3 x)
- G** M5 hexagon screw (3 x)
- H** Holder
- I** AAG control unit (not supplied in the retrofit kit)
- J** Mini 5 A fuse (6 x)
- K** Cable ties (15 x)
- L** Bus interface (only for cars without bus interface, not supplied with the retrofit kit)
- M** Retrofitting the bus interface (only for cars without bus interface already installed)
- N** Storage tray (for cars without a spare wheel only)
- O** Velcro strip (only for cars without spare wheel)
- P** M6 hexagonal bolt with washer (for cars without a spare wheel only)
- Q** 20 A fuse (3 x, not included in the retrofit kit)
- R** Fuse holder (not supplied with the retrofit kit)
- S** Fan frame with fan (not supplied with the retrofit kit)
- T** Hexagon nut with washer (not supplied with the retrofit kit)

2. Preparatory work

	ISTA/AIR No.
Disconnect the negative battery cable	61 20 900
The following components must be removed first of all	
Rear bumper trim	51 12 156
Luggage compartment floor trim	51 47 101
Luggage compartment wheel arch trim, right	51 47 161
Rear left or right door sill cover strip	51 47 030
Front left or right door sill cover strip	51 47 000
Bottom left or right dashboard trim	51 45 195
Footwell side trim on left or right A-pillar	51 43 075
Glove box	51 16 366
Rear seat	52 26 005
Only if fan replacement is necessary	
Replace the fan frame with fan	17 40 ...

3. Retrofit wiring harness connection diagram

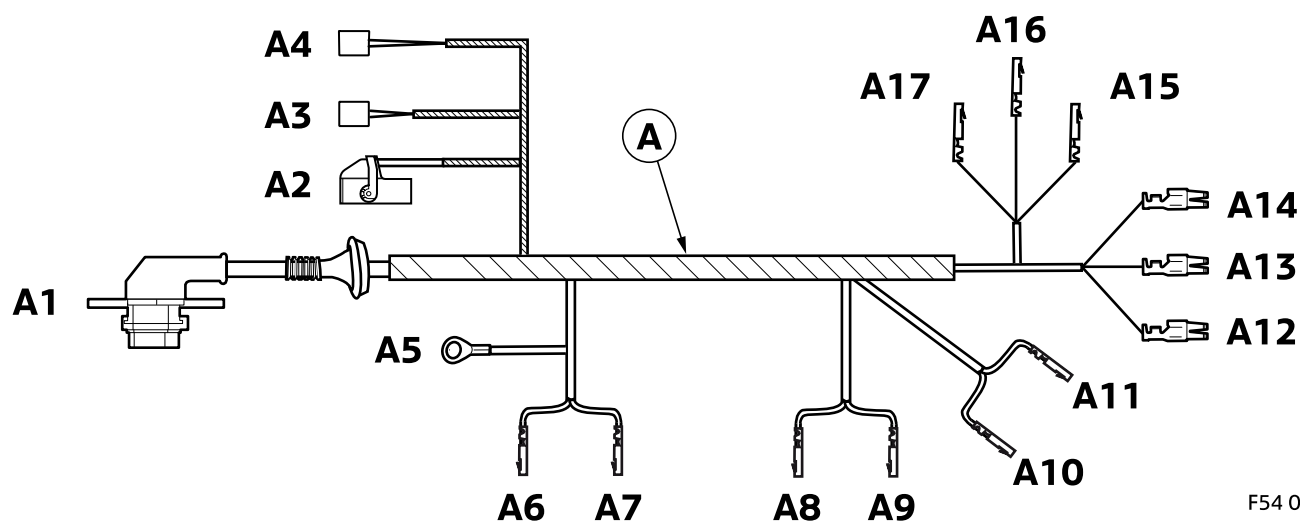

F54 0042 Z

Item	Designation	Signal	Cable colour/ cross-section	Connection location in the car	Abbreviation/ slot
A	Retrofit wiring harness	---	---	---	---
A1	SW 13-pin socket casing	---	---	Connect to socket E	---
A2	SW 24-pin socket casing	---	---	Connect to control unit I	A255*1B
A3	SW 6-pin socket casing	---	---	Connect to control unit I	A255*2B
A4	SW 10-pin socket casing	---	---	Connect to control unit I	A255*3B
A5	M6 ring eyelet	Terminal 31	BR	Screw onto rear right wheel arch ground support point	Z10*7B
A6	Socket contact	B-CAN_H	SW/RT 0.35 mm ²	Only cars with previously-installed R2 bus interface Connect to plug R2*1B Cars without an existing bus interface R2 only Connect to branch M1	R2*1B PIN 9 M1 PIN 9
A7	Socket contact	B-CAN_L	SW/WS 0,35 mm ²	Only cars with previously-installed R2 bus interface Connect to plug R2*1B Cars without an existing bus interface R2 only Connect to branch M1	R2*1B PIN 22 M1 PIN 22
A8	Socket contact	WBL	BL 0.35 mm ²	Connect to BDC plug A258	A258*3B PIN 17
A9	Socket contact	BLSH	SW/GE 0.35 mm ²	Connect to BDC plug A258	A258*3B PIN 16
A10	Socket contact	Terminal 30F_ON	RT/GR 0.35 mm ²	Connect to BDC plug A258	A258*3B PIN 4
A11	Socket contact	Terminal 30F_OFF	BL/GE 0.35 mm ²	Connect to BDC plug A258	A258*3B PIN 5
A12	Double flat spring contact	Terminal 30B_F63	RT/SW 2.50 mm ²	Connect to front fuse box Z7	Z7*4B PIN 28
A13	Double flat spring contact	Terminal 30F_F120	RT/VI 2.50 mm ²	Connect to front fuse box Z7	Z7*7B PIN 1
A14	Double flat spring contact	Terminal 30F_F119	RT/GE 2.50 mm ²	Connect to front fuse box Z7	Z7*7B PIN 2
A15	Socket contact	Terminal 30F_OFF	BL/GE 0.35 mm ²	Connect to front fuse box Z7	Z7*7B PIN 10
A16	Socket contact	Terminal 30F_ON	RT/GR 0.35 mm ²	Connect to front fuse box Z7	Z7*7B PIN 11
A17	Socket contact	Terminal 31	BR 0.35 mm ²	Connect to front fuse box Z7	Z7*7B PIN 12

4. Bus interface retrofit wiring harness connection diagram

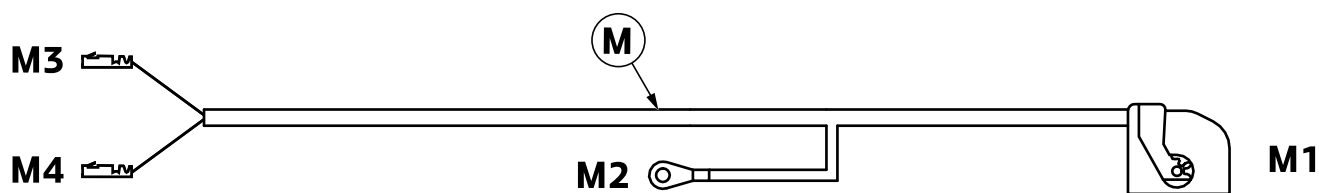

F54 0043 Z

Item	Designation	Signal	Cable colour/ cross-section	Connection location in the car	Abbreviation/ slot
M	Bus interface retrofit wiring harness	---	---	Only for cars without bus interface R2 already installed	---
M1	SW 26-pin socket casing	---	---	Connect to bus interface L	---
M2	M6 ring eyelet	Terminal 31	BR	Screw onto rear right wheel arch ground support point	Z10*7B
M3	Socket contact to twisted cable	B-CAN_H	OR 0.35 mm ²	Connect to BDC plug A258	A258*8B PIN 50
M4	Socket contact to twisted cable	B-CAN_H	BR/GE 0.35 mm ²	Connect to BDC plug A258	A258*8B PIN 49

5. Installation and cabling diagram for LHD (left-hand drive) cars

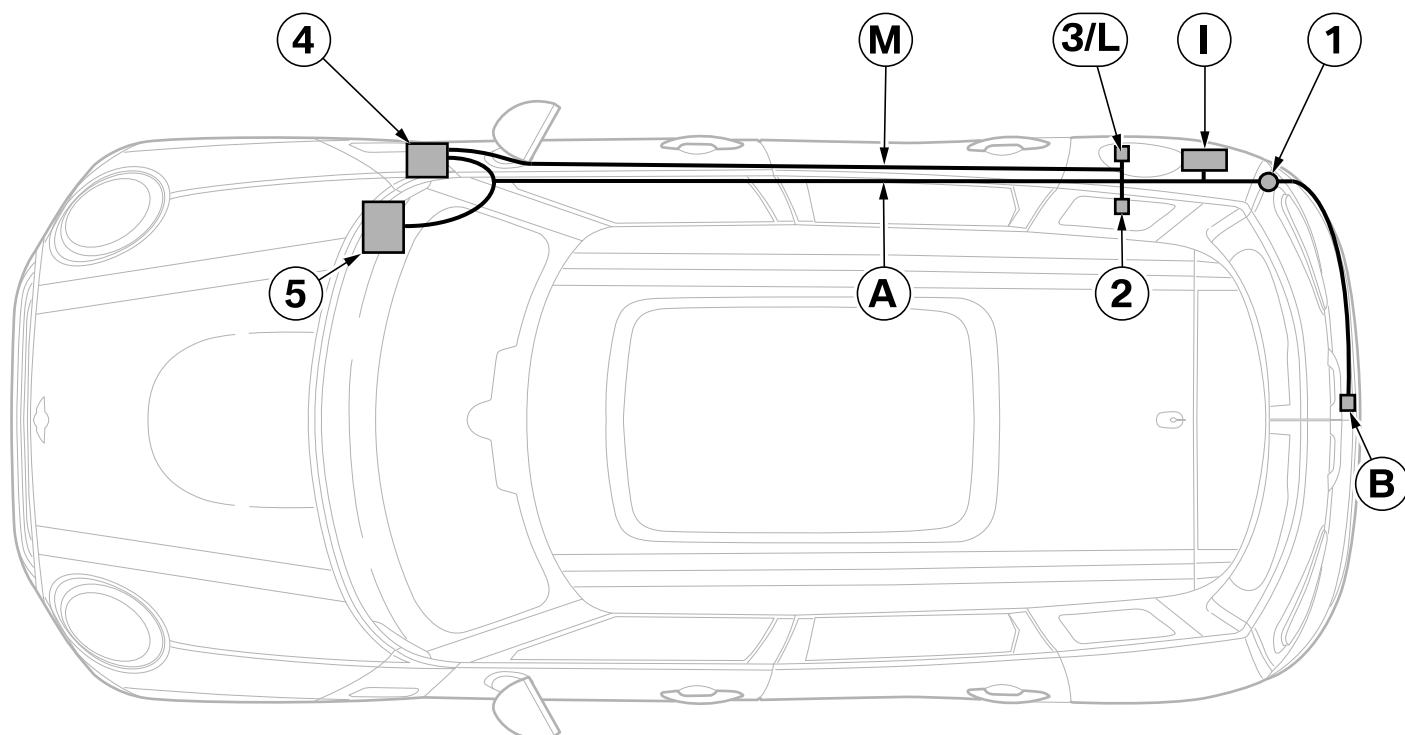

F54 0044 Z

- A** Retrofit wiring harness
- B** Trailer tow hitch
- I** AAG control unit
- L** Bus interface (only for cars without bus interface **R2** already installed)
- M** Bus interface retrofit wiring harness (only for cars without bus interface **R2** already installed)

- 1** Drilling point/rubber grommet
- 2** Ground support point **Z10*7B**
- 3** Bus interface **R2/L**, plug **R2*1B** or branch **M1**
- 4** BDC **A258**, plugs **A258*3B** and **A258*8B**
- 5** Fuse box **Z7**, module **Z7*4B** and **Z7*7B**

6. Installation and cabling diagram for RHD (right-hand drive) cars

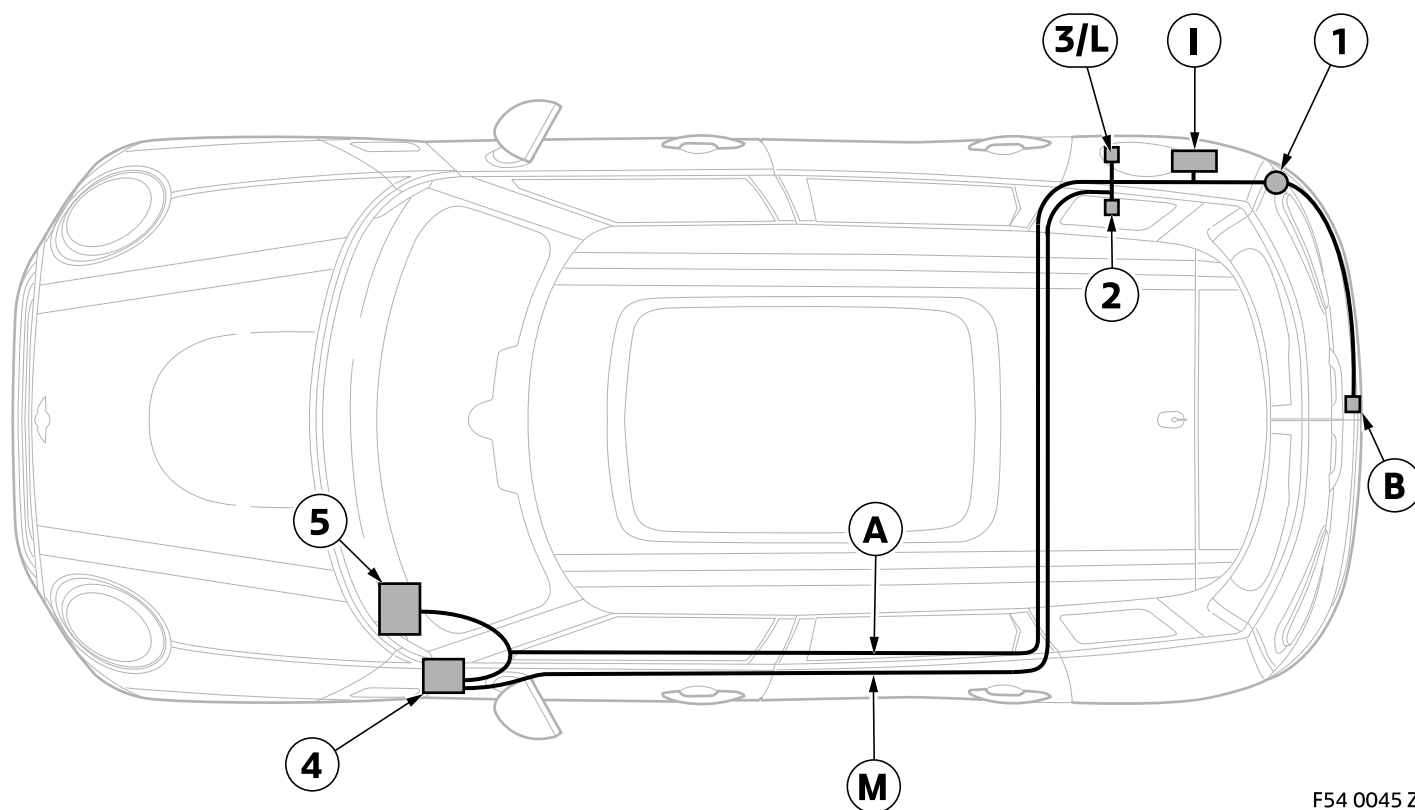

F54 0045 Z

- A** Retrofit wiring harness
- B** Trailer tow hitch
- I** AAG control unit
- L** Bus interface (only for cars without bus interface **R2** already installed)
- M** Bus interface retrofit wiring harness (only for cars without bus interface **R2** already installed)

- 1** Drilling point/rubber grommet
- 2** Ground support point **Z10*7B**
- 3** Bus interface **R2/L**, plug **R2*1B** or branch **M1**
- 4** BDC **A258**, plugs **A258*3B** and **A258*8B**
- 5** Fuse box **Z7**, module **Z7*4B** and **Z7*7B**

7. Retrofitting the bus interface (only for cars without bus interface already installed)

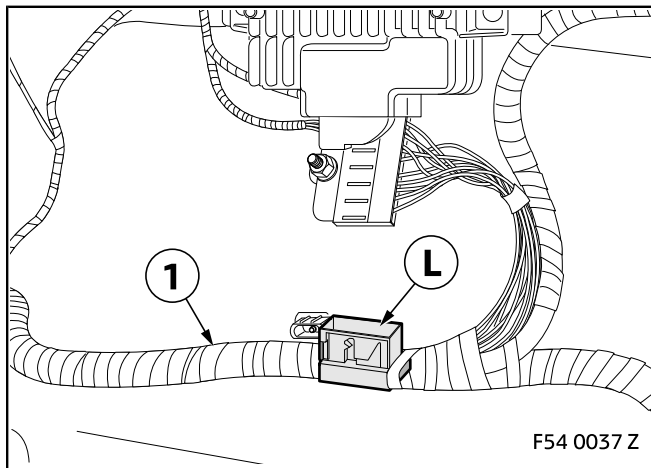

Secure bus interface **L** using insulating tape to the standard wiring harness (1).

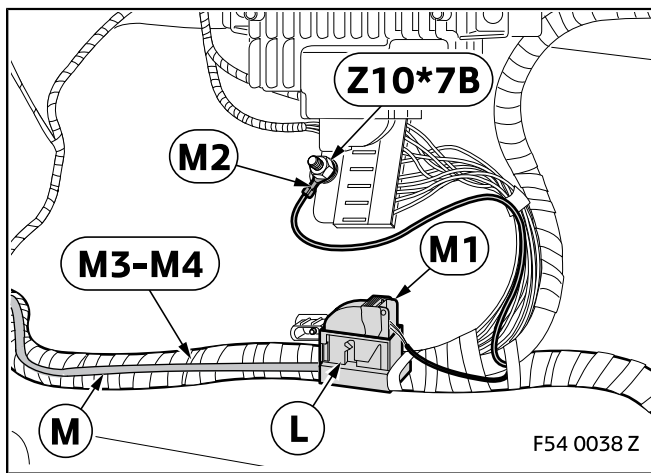

Connect bus interface retrofit wiring harness **M** as follows:

- Connect branch **M1** to bus interface **L**
- Screw branch **M2**, M6 ring eyelet, onto ground support point **Z10*7B**
- Route branches **M3-M4** onwards to the installation point of the BDC

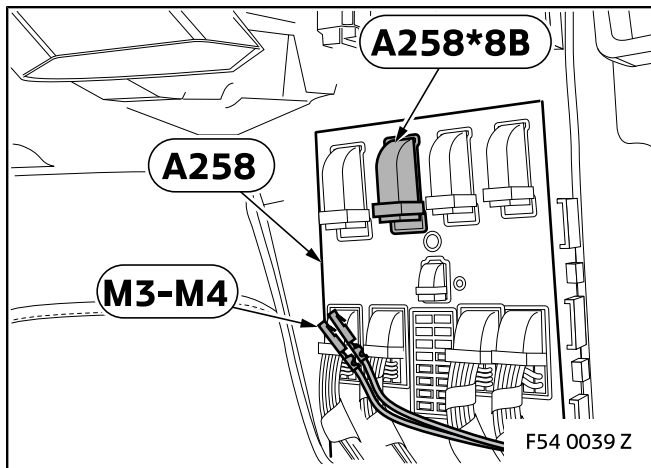

Connect branches **M3-M4** as follows to plug **A258*8B**, SW 54-pin socket casing of BDC **A258**:

- Branch **M3**, OR cable, to PIN 50
- Branch **M4**, BR/GE cable, to PIN 49

8. Installing the trailer tow hitch

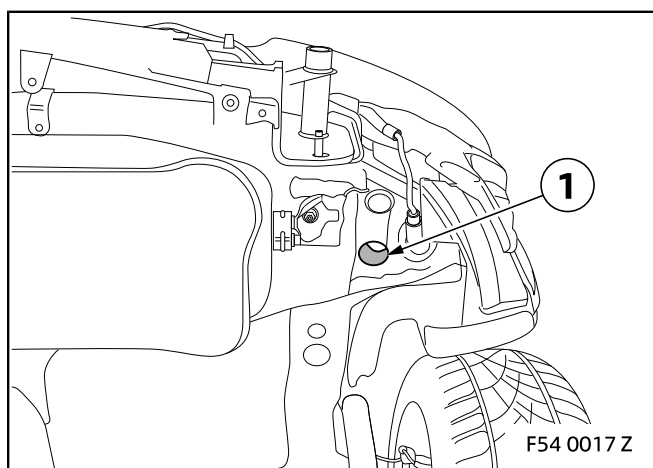

▶ When drilling, ensure that you do not damage the cable behind. ◀

Remove the dummy plug (1) on the rear closing panel on the right and widen the opening to a diameter of 25 mm.

Deburr the hole and coat the bare surfaces with preservative.

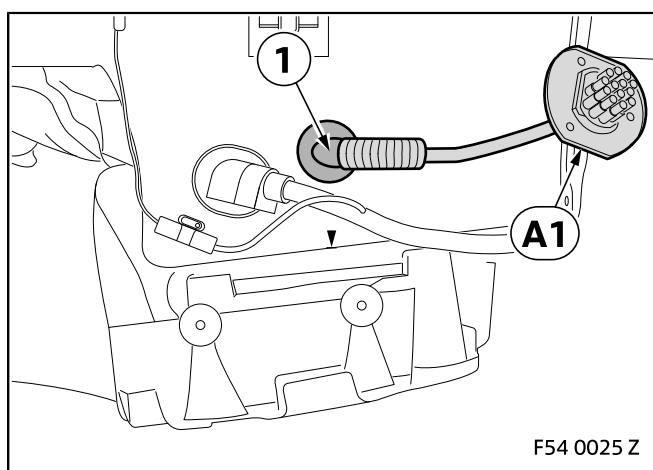

Insert grommet (1) into the hole so it is waterproof.

Route cable branch **A1** outside the car.

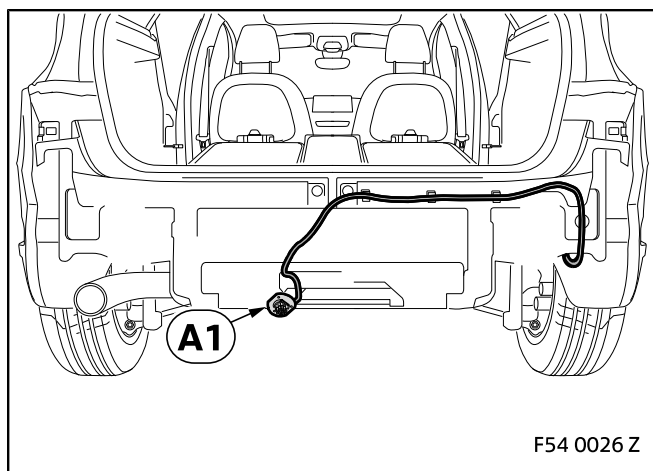

Route the cable branch **A1** outside the car to the location of the trailer tow hitch.

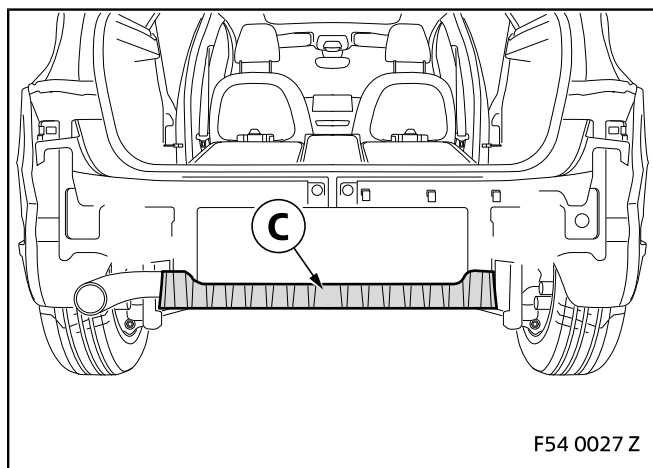

Fit heat insulation **C** using existing fastening material.

8. Installing the trailer tow hitch

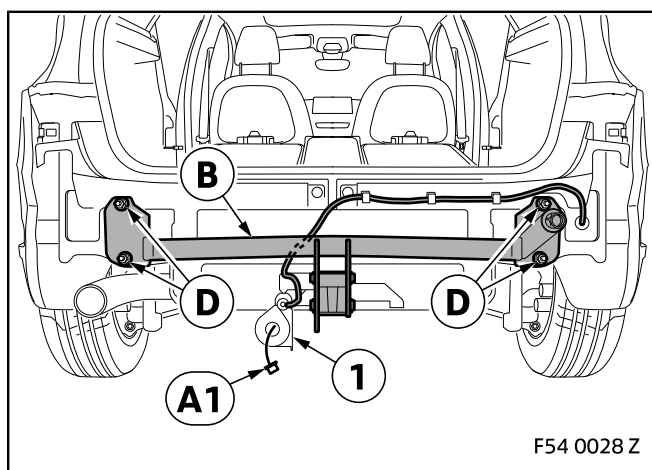

▶ Note the tightening torque value: 108 Nm. ◀

Bolt trailer tow hitch **B** into place using hexagon nuts **D**.

Guide branch **A1** through the pivot device socket (1).

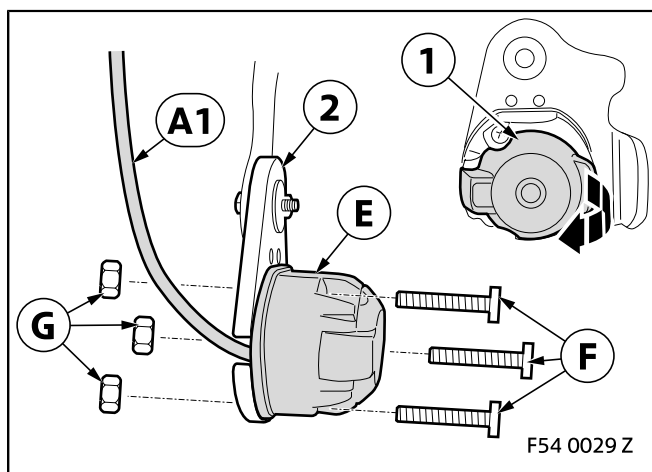

▶ The socket cover (1) must open to the left. ◀

Connect branch **A1** to socket **E** and secure using pan-head screw **F** and hexagon nuts **G** to the swivel device socket (2).

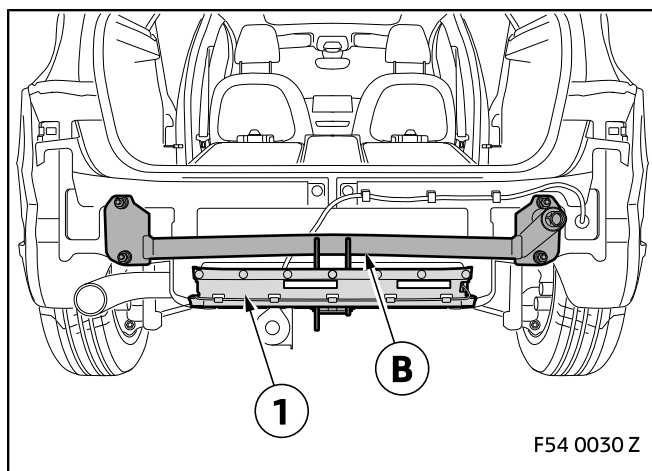

Fit the support (1) using the existing fastening material to trailer tow hitch **B**.

9. Routing and connecting the retrofit wiring harness

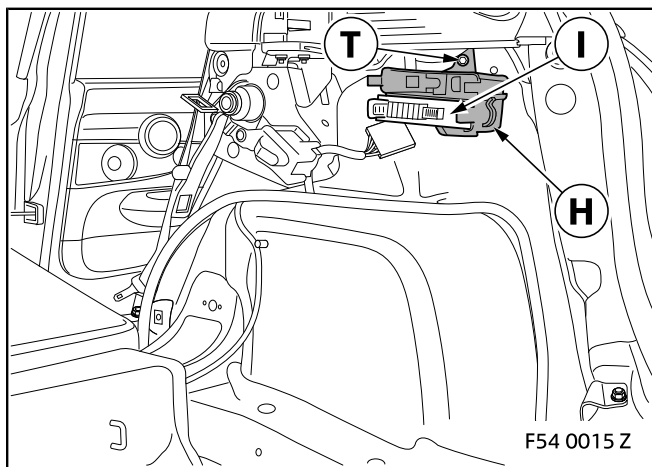

Install holder **H** using hexagon nut **T**.
Insert AAG control unit **I** into holder **H**.

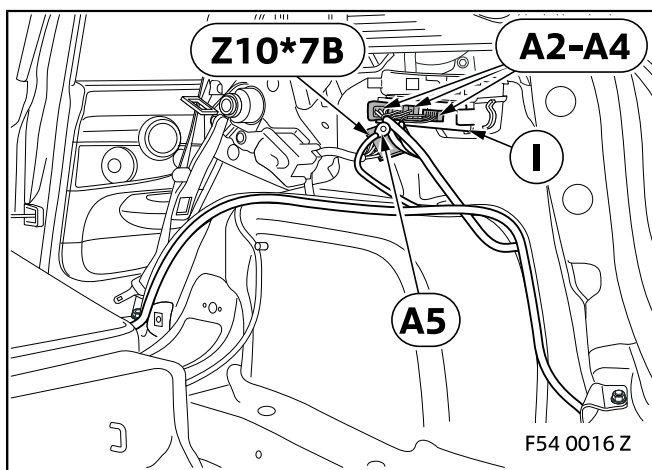

Connect branches **A2-A4** to AAG control unit **I**.
Screw branch **A5** onto ground support point **Z10*7**.

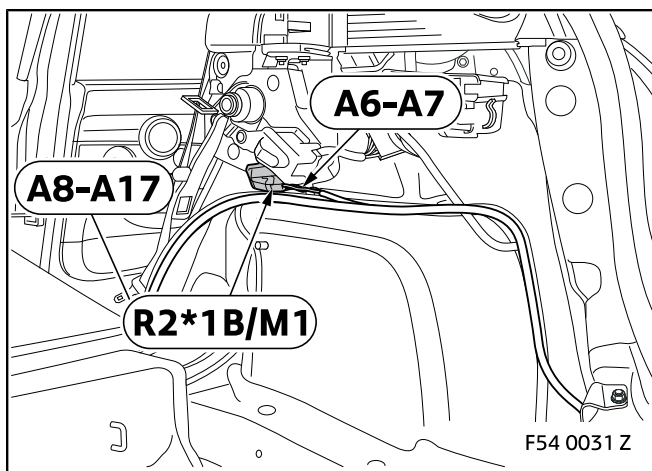

Connect branches **A6-A7** as follows to plug **R2*1B** or branch **M1**, SW 26-pin socket casing:

- Branch **A6**, SW/RT cable, to PIN 9
- Branch **A7**, SW/WS cable, to PIN 22

LHD (left-hand drive) cars only

Route branches **A8-A17** along the right-hand side of the car to the installation site of the BDC on the right A-pillar.

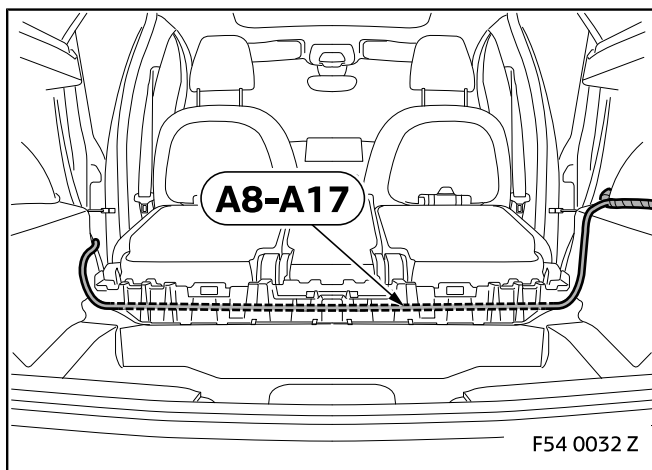

RHD (right-hand drive) cars only

Route branches **A8-A17** along the left-hand side of the car to the installation site of the BDC on the left A-pillar.

9. Routing and connecting the retrofit wiring harness

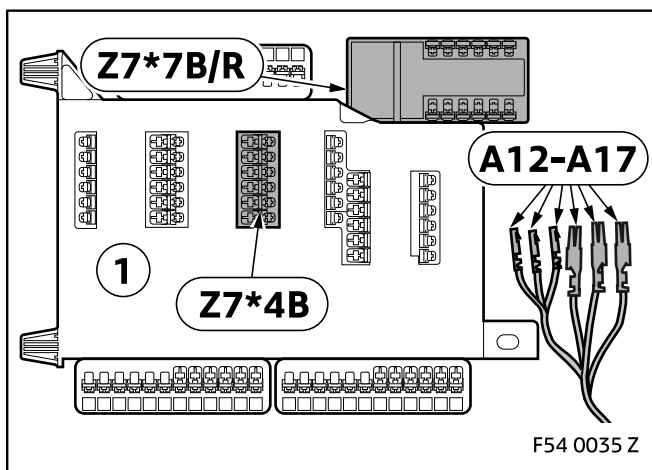
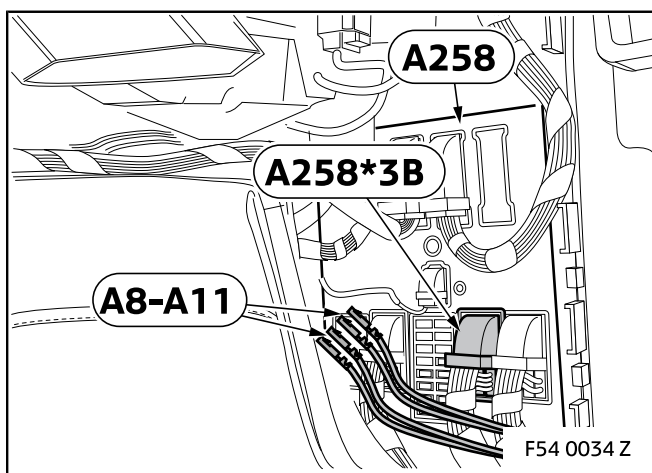
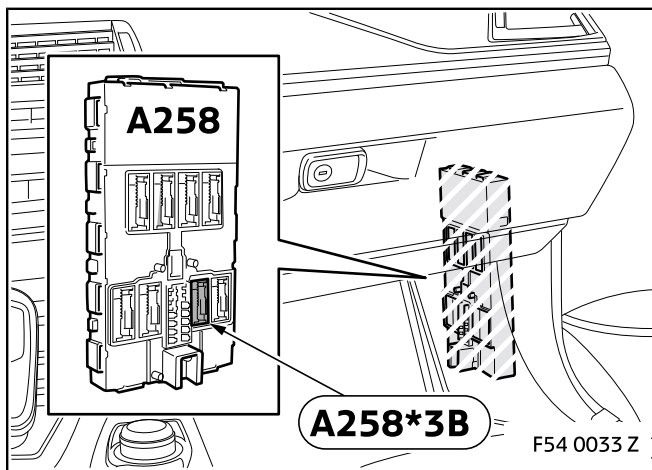

All cars

Connection locations on BDC **A258**:

- **A258*3B**, SW 54-pin socket casing

Connect branches **A8-A11** as follows to plug **A258*3B**, SW 54-pin socket casing, of BDC **A258**:

- Branch **A8**, BL cable, to PIN 17
- Branch **A9**, SW/GE cable, to PIN 16
- Branch **A10**, RT/GR cable, to PIN 4
- Branch **A11**, BL/GE cable, to PIN 5

⚠ Fuses can fall out when connecting the plug to the front fuse box (1). Ensure that all the fuses are replaced in their correct position. If fuse holder **Z7*7B** is not present, use fuse holder **R**. ◀

Connect branch **A12**, RT/SW cable, to PIN 28 of module **Z7*4B** on the front fuse box (1):

Connect branches **A13-A17** as follows to fuse holder **Z7*7B** on the front fuse box (1):

- Branch **A13**, RT/VI cable, to PIN 1
- Branch **A14**, RT/GE cable, to PIN 2
- Branch **A15**, BL/GE cable, to PIN 10
- Branch **A16**, RT/GR cable, to PIN 11
- Branch **A17**, BR cable, to PIN 12

9. Routing and connecting the retrofit wiring harness

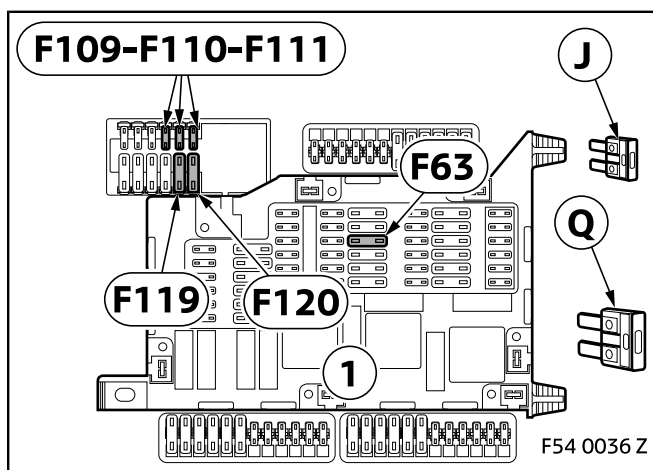

Insert fuses **Q** into slots **F119**, **F120** and **F63** of the fuse box (1).

Insert fuses **J** into slots **F109**, **F110** and **F111** of the fuse box (1).

10. Fitting the oddments tray

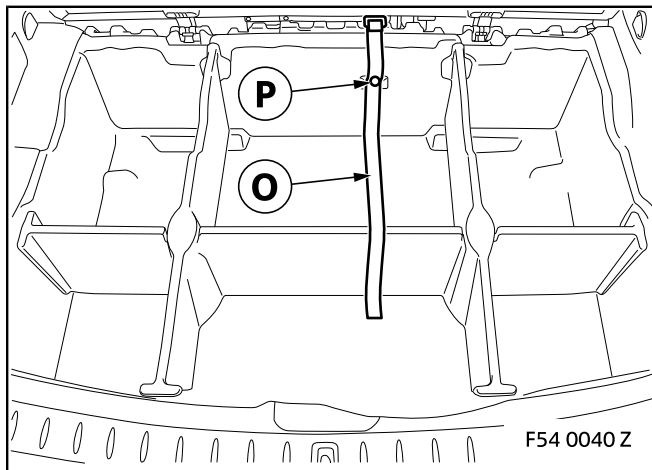

Screw on Velcro strip **O** using hexagon screw **P** in the spare wheel trough.

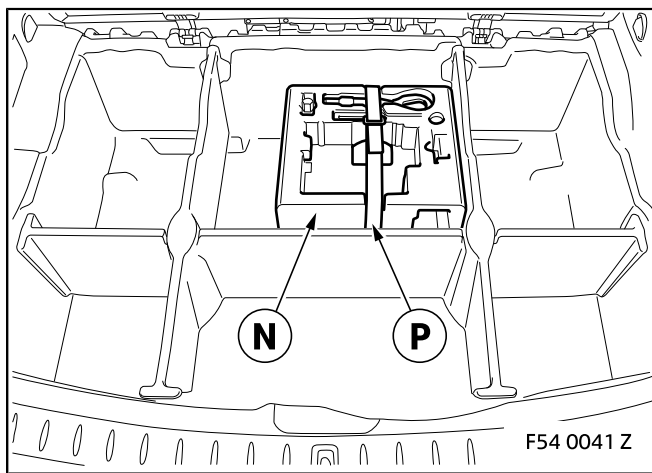

Insert oddments tray **N** into the spare wheel trough and lash tightly in place using Velcro strip **P**.

11. Concluding work and coding

The retrofit system requires programming/coding.

- Connect the battery
- Connect the battery charger to the car
- Connect the car to the ISTA workshop system
- Open the ISTA car programming system
- Please refer to the instructions provided in the ISTA application documentation for working with ISTA

Two sessions are required for coding the removable trailer tow hitch:

- **Session 1:** Select "Preparation for removable trailer tow hitch retrofit" using the – **Conversions** – path and work through the action plan
- **Session 2:** Select "Preparation for retrofit removable trailer tow hitch" using the – **Conversions** – path and work through the action plan
- If necessary, carry out a vehicle test using the ISTA system, and note, or work through, any errors that has been recorded
- Conduct a function test
- Re-assemble the car
- Print out the "Customer information" section at the end of these installation instructions and give it to the customer.
- Give the accessories supplied with the retrofit kit to the customer

Carry the installation instructions in the car

-  These installation instructions must be kept with the vehicle documents. Notify the customer that these installation instructions must be kept in the car at all times until the trailer tow hitch has been entered in the vehicle documents. ◀

12. Wiring diagram

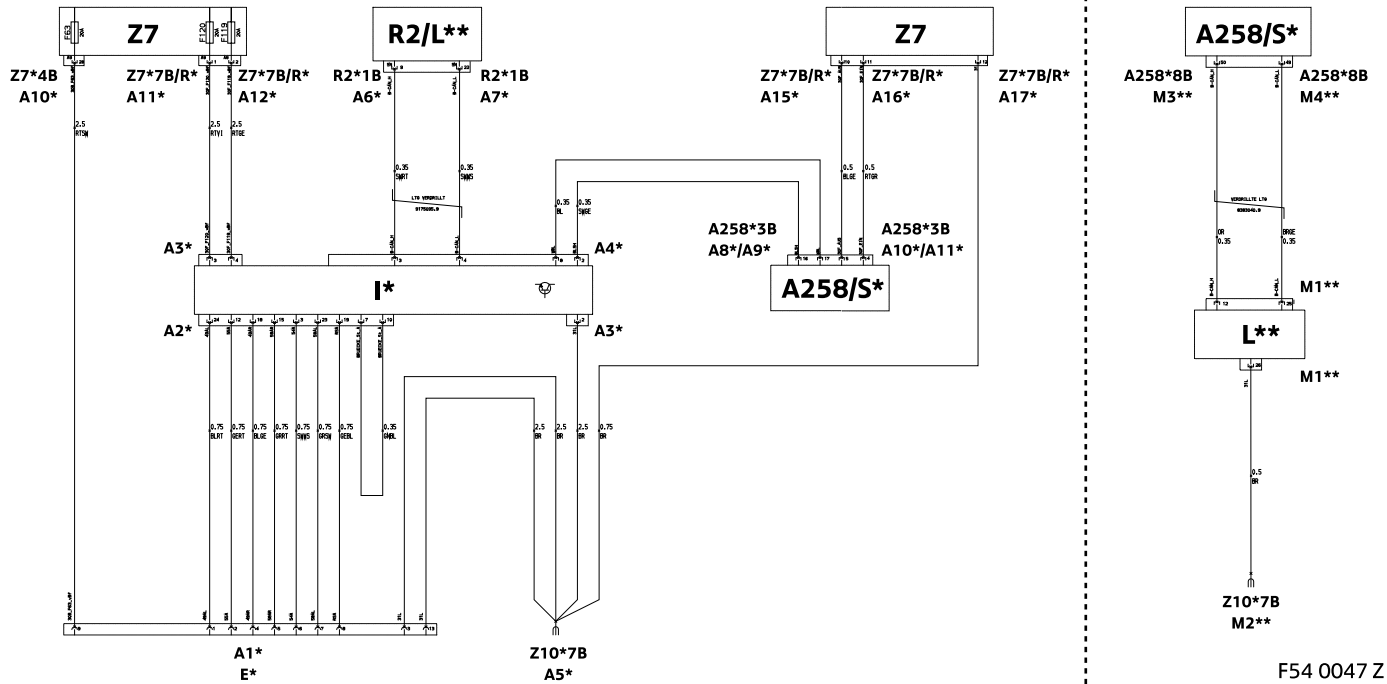

Legend

- A1*** SW 13-pin socket housing to socket **E***
- A2*** SW 24-pin socket housing, to control unit **I***
- A3*** SW 6-pin socket housing, to control unit **I***
- A4*** SW 10-pin socket housing, to control unit **I***
- A5*** M6 ring eyelet, to ground support point **Z10*7B** of rear right wheel arch
- A6*** Socket contact, SW/RT cable, to PIN 9 of plug **R2*1B/M1****
- A7*** Socket contact, SW/WS cable, to PIN 22 of plug **R2*1B/M1****
- A8*** Socket contact, BL cable, to PIN 16 of plug **A258*3B**
- A9*** Socket contact, SW/GE cable, to PIN 17 of plug **A258*3B**
- A10*** Socket contact, RT/GR cable, to PIN 4 of plug **A258*3B**
- A11*** Socket contact, BL/GE cable, to PIN 5 of plug **A258*3B**
- A12*** Double flat spring contact, RT/SW cable, to PIN 28 of plug **Z7*4B**
- A13*** Double flat spring contact, RT/VI cable, to PIN 1 of plug **Z7*7B**
- A14*** Double flat spring contact, RT/GE cable, to PIN 2 of plug **Z7*7B**
- A15*** Socket contact, BL/GE cable, to PIN 10 of plug **Z7*7B**
- A16*** Socket contact, RT/GR cable, to PIN 11 of plug **Z7*7B**
- A17*** Socket contact, BR cable, to PIN 12 of plug **Z7*7B**

- M1**** SW 26-pin socket housing, to bus interface **L****
- M2**** M6 ring eyelet, to ground support point **Z10*7B** of rear right wheel arch
- M3**** Socket contact, OR cable, to PIN 50 of plug **A258*8B**
- M4**** Socket contact, BR/GE cable, to PIN 49 of plug **A258*8B**

- E*** Socket
- I*** AAG control unit
- L**** Bus interface (cars without bus interface **R2** already installed only)
- R*** Fuse holder

12. Wiring diagram

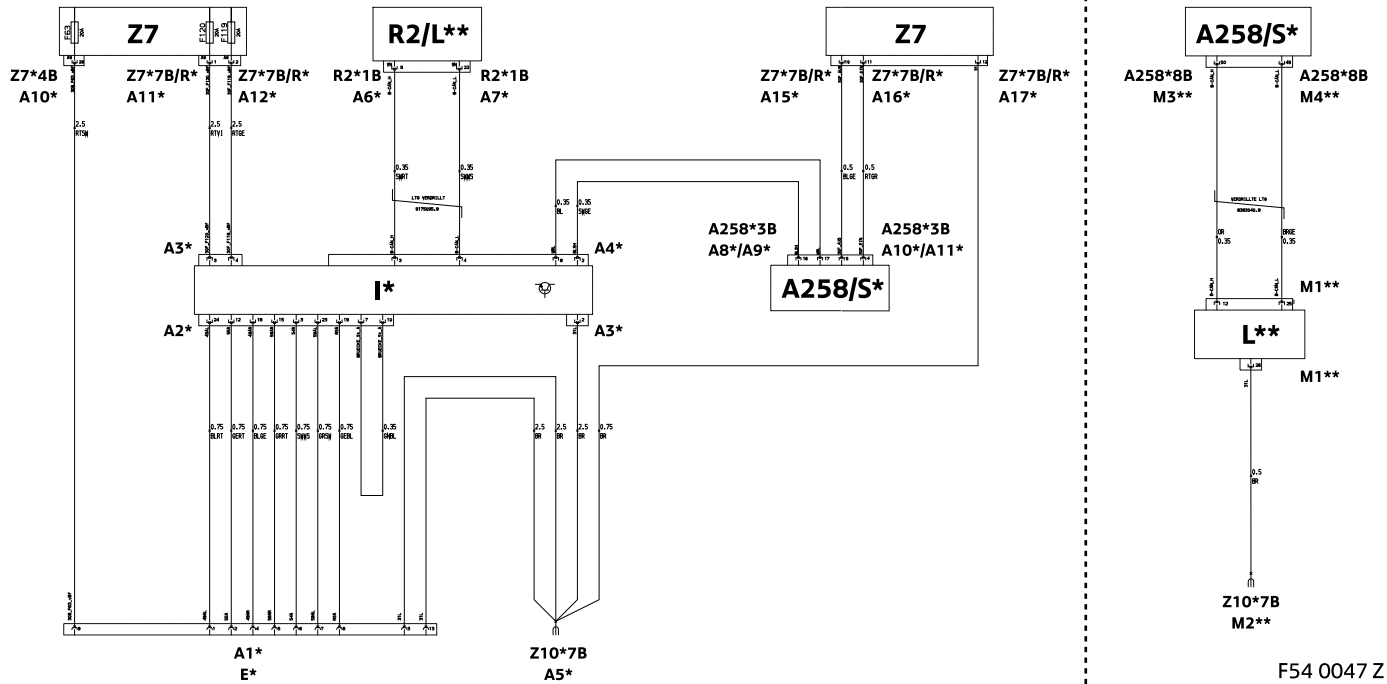

Legend

- A258** Body Domain Controller **BDC**
- R2** Bus interface on the rear right wheel arch
- Z7** Front fuse box

- A258*3B** SW 54-pin socket casing on **BDC**
- A258*8B** SW 54-pin socket casing on **BDC**
- R2*1B** SW 26-pin socket housing on bus interface **R2**
- Z7*4B** Module on fuse box **Z7**
- Z7*7B** Fuse holder on fuse box **Z7**
- Z10*7B** Ground support point on the rear right wheel arch

All of the designations marked with * apply only to these installation instructions or this wiring diagram.

All of the designations marked with ** apply only to cars without the **R2** bus interface already installed.

Cable colours

BL	Blue	GR	Grey	RT	Red
BO	Bordeaux (Burgundy)	L-GN	Light green	SW	Black
BR	Brown	NT	Natural	TR	Transparent
GE	Yellow	OR	Orange	VI	Violet
GN	Green	RO	Pink	WS	White

13. Coupling ball clearances and installation height for towing ball coupling

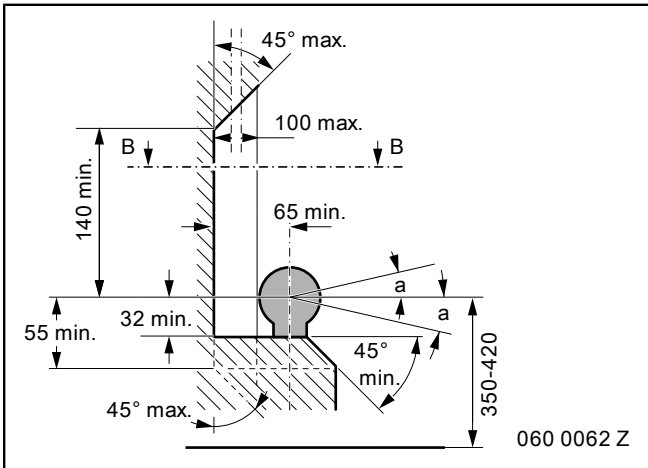

Space for coupling ball, side view.

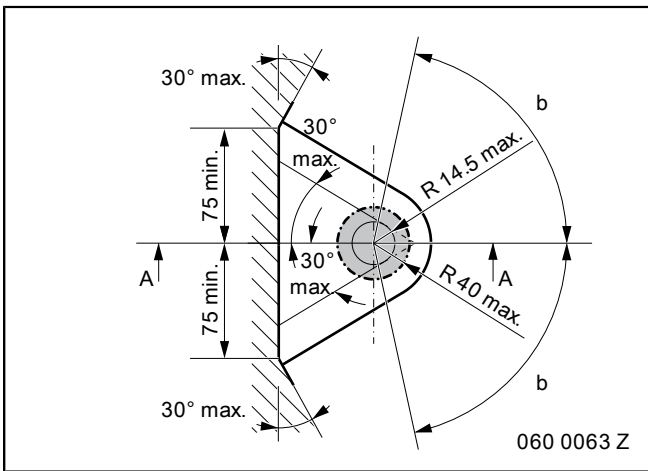

Space for coupling ball, plan view.

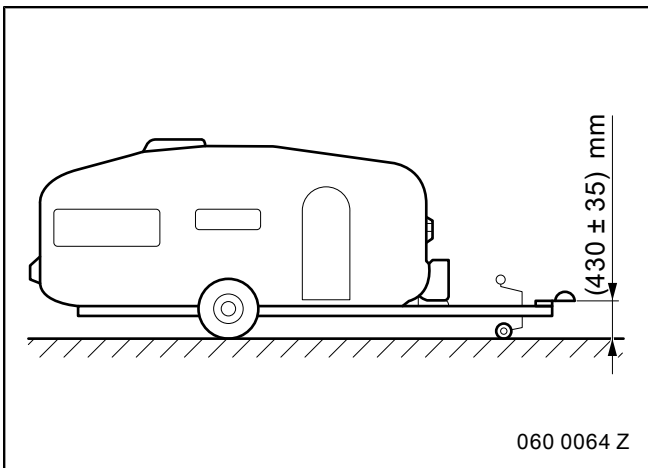

Installation height for the towing ball coupling.

14. Customer information

! The ball head must be removed when not in use and securely stowed in the oddments tray of your car's lower storage space floor. Never carry the ball head (1) unsecured in the boot. ◀

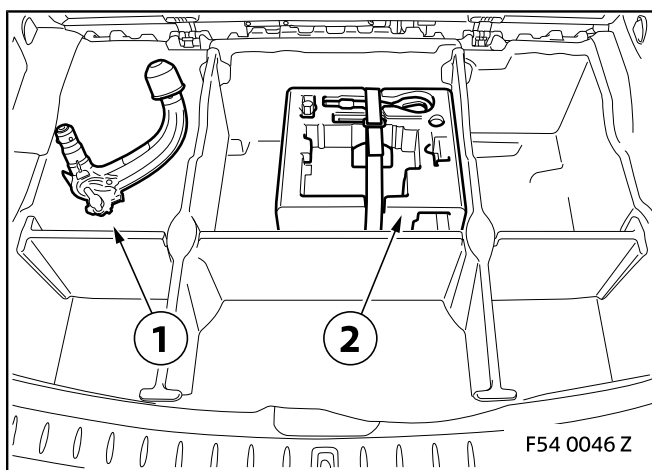

Remove the ball head (1).

Store the ball head in the oddments tray (2).

Secure the oddments tray (2) to prevent it from sliding around.